

# APEM

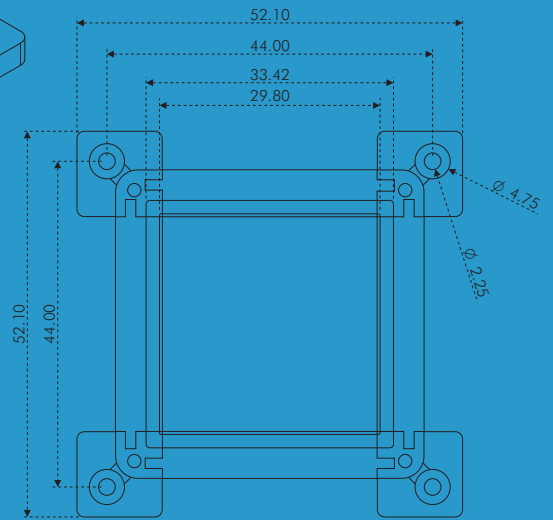

## 5000 SERIES - POTENTIOMETER JOYSTICKS

COST EFFECTIVE    LOW PROFILE INSTALLATION    ROHS COMPLIANT  
SIMPLE INTERFACE    ERGONOMIC DESIGN    LOW CURRENT DRAIN  
TWO OR THREE AXES    SPECIFICALLY DESIGNED FOR KEYBOARDS

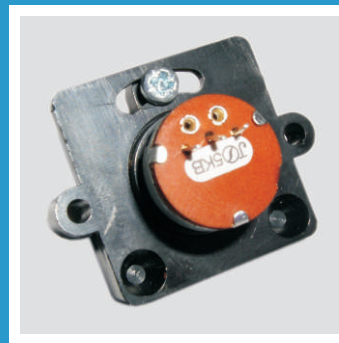

**ERMEC**  
Distribución de componentes eléctricos y electrónicos

**ERMEC Barcelona**  
c/Francesc Teixidó, 22  
E-08916 Badalona  
Spain

**ERMEC Madrid**  
c/Sagasta, 8, 1ª Pl.  
E-28004 Madrid  
Spain

**ERMEC Portugal**  
[portugal@ermec.com](mailto:portugal@ermec.com)

Tel.: (+34)902.450.160  
Fax: (+34)902.433.088  
[info@ermec.com](mailto:info@ermec.com)  
[www.ermec.com](http://www.ermec.com)

[www.apem.com](http://www.apem.com)

# 5000 SERIES - POTENTIOMETER JOYSTICKS

## PRODUCT DESCRIPTION

### GENERAL DESCRIPTION

The 5000 Series is a range of low profile, cost optimised potentiometer joysticks. These joysticks are designed specifically for applications such as keyboards where installed depth and cost are critical. Configurable in up to three axes, for pan, tilt and zoom control of such applications as CCTV cameras the 5000 Series is offered with a range of handles, bezels and mounting styles.

### MOUNTING

The 5000 Series is a sub-panel mounting joystick. It is offered with two mounting options; option B allows the user to screw down from the front face of the panel, through the bezel and into the joystick. Option A has four additional screwing points on the body of the joystick, allowing the user to screw from the underside of the panel, up through the joystick and into the panel, and in so doing the screw heads are concealed. Option B is designed for use with gaiter option 1 and bezel option 2, where as option A is designed for use with bezel option 1.

### POTENTIOMETERS

The 5000 Series is offered as standard with 5K potentiometers which have 220° tracks. With a shaft deflection angle of nominally 40°, a typical 5V supply would therefore result in a full scale nominal deflection from 2V to 3V, operating about a nominal 2.5V centre. The potentiometers used on the 5000 Series are designed for use as a variable potential divider, rather than a two pin variable resistor. Noise generated by the contact resistance of the wiper to the track dictates that for optimum performance the output signals should be fed into a load of greater than 100K.

### OPERATING MODE

The operating mode of the joystick may be specified as either sprung to centre, or alternatively with a "ratchet" position, allowing a positive detented feel in three positions either side of centre (available on X & Y axes only).

### USER FLEXIBILITY

The 5000 Series is designed to be as flexible as possible whilst keeping cost optimal. As standard the unit is offered without a wiring harness, allowing customers to wire the unit according to the needs of the individual application. The joystick may be factory configured with cable harnesses upon request. The 5000 Series is offered with an open square gate as standard, again allowing the customer the flexibility of determining in software how the precise control is configured.

### LEVERS

Lever option 1 should be specified for any two axes configuration. Lever option 8 is for three axes operation. Apem offers a range of non standard lever options, including custom and lower profile options, for more details of these or any other 5000 Series enquiries please contact your local Apem representative.



<b>ERMEC Barcelona</b> c/Francesc Teixidó, 22 E-08916 Badalona Spain	<b>ERMEC Madrid</b> c/Sagasta,8,1ª Pl. E-28004 Madrid Spain	<b>ERMEC Portugal</b> <a href="mailto:portugal@ermec.com">portugal@ermec.com</a>	Tel.: (+34)902.450.160 Fax: (+34)902.433.088 <a href="mailto:info@ermec.com">info@ermec.com</a> <a href="http://www.ermec.com">www.ermec.com</a>
---	--	---	---

Note: The company reserves the right to change specifications without notice.

# 5000 SERIES - POTENTIOMETER JOYSTICKS

## PRODUCT CONFIGURATION

### STANDARD OPTIONS

The 5000 Series is available with a range of standard options, to specify your joystick, simply choose one option from each column. An example is shown below.

5	S	2	5	1	S	0	F	2	1	00
SERIES	MOUNTING	AXES	POTS	LEVER	SPRING	WIRED	HANDLE	BEZEL	GAITER	MODIFIER
5000 (5)	Sub Mount A (S) Sub Mount B (T)	Two (2) Three (3)	5 K 220° (5)	Standard (1) For 3 Axes (8)	Ratchet (R) Standard (S)	None (0) 200mm (1)	Conical (F) Tall Conical (H) Tall Slimline (V) Third Axis (W)	Not supplied (0) Square (1) Circular (2)	Not supplied (0) Standard (1)	None (00)

### EXAMPLE CONFIGURATIONS

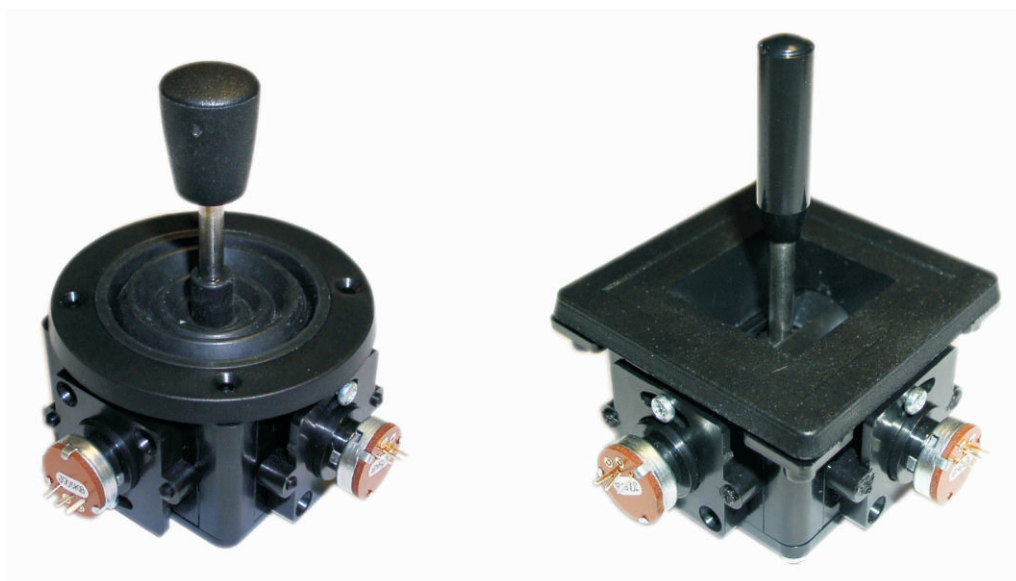

### TECHNICAL SPECIFICATION

All parameters and dimensions shown maybe subject to specification, please refer to Apem for details.

Life Cycles	: >1 Million Mechanical Operations	Lever Travel	: +/-20 Degrees from Centre
Lever Material	: Stainless Steel	Body Material	: ABS
Handle Material	: Nylon or Aluminium	Gaiter Material	: Neoprene
Temperature Range	: -10°C to +55°C	Resistance Tolerance	: +/-20%
Maximum Voltage	: 10V	Rated Power	: 0.125W per Potentiometer
Weight	: 50 Grams	Potentiometer Alignment	: To Centre of Track (+/-50mV)



**ERMEC Barcelona**  
c/Francesc Teixidó, 22  
E-08916 Badalona  
Spain

**ERMEC Madrid**  
c/Sagasta, 8, 1ª Pl.  
E-28004 Madrid  
Spain

**ERMEC Portugal**  
[portugal@ermec.com](mailto:portugal@ermec.com)

Tel.: (+34)902.450.160  
Fax: (+34)902.433.088  
[info@ermec.com](mailto:info@ermec.com)  
[www.ermec.com](http://www.ermec.com)

[www.apem.com](http://www.apem.com)

# 5000 SERIES - POTENTIOMETER JOYSTICKS

## USEFUL DIMENSIONS

### MOUNTING OPTION A

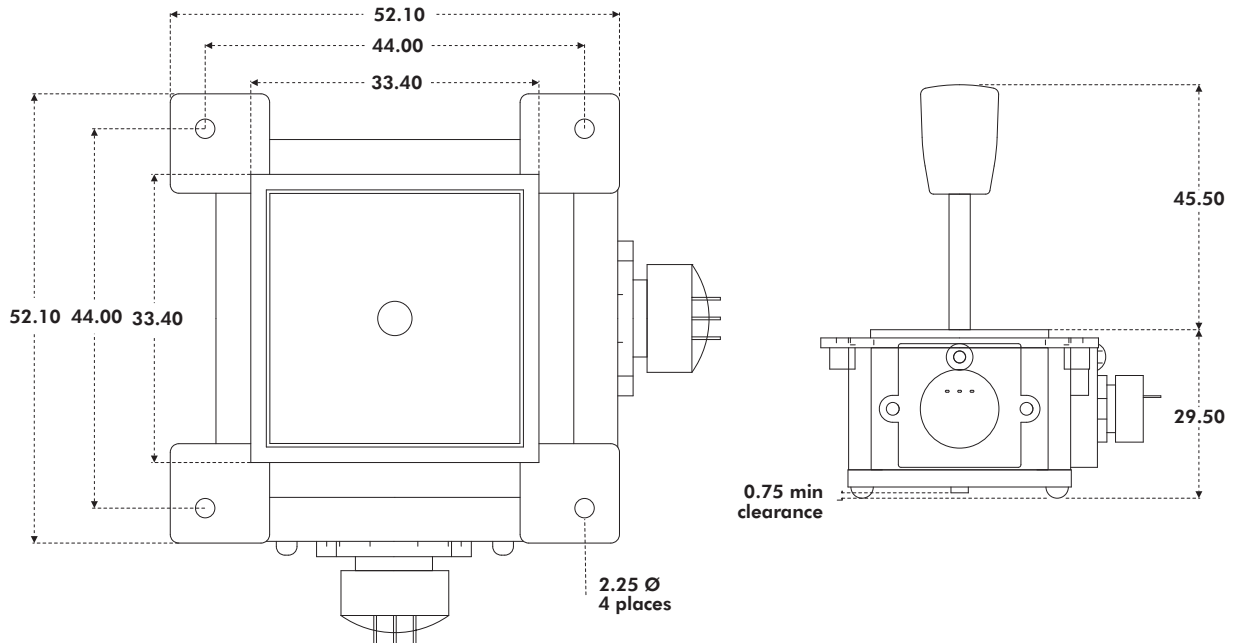

### MOUNTING OPTION B

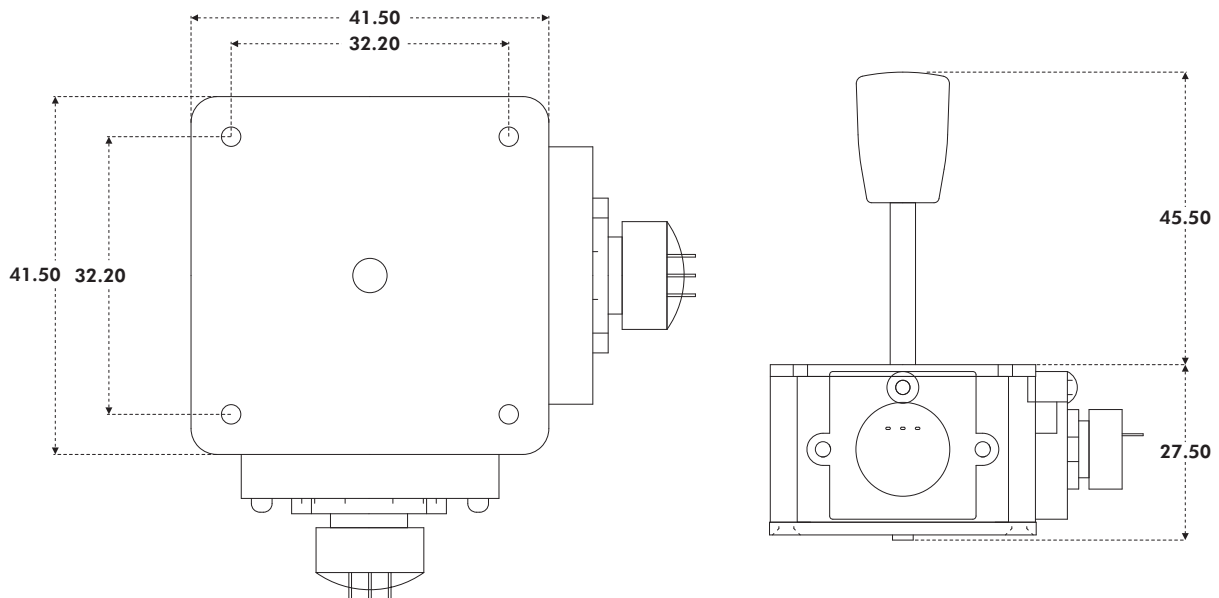

Note: The dimensions shown are for a generic two axes 5000 Series with the F type handle. For specific dimensions of this or any other configuration please refer to Apem.

**ERMEC**  
Distribución de componentes eléctricos y electrónicos

**ERMEC Barcelona**  
c/Francisc Teixidó, 22  
E-08916 Badalona  
Spain

**ERMEC Madrid**  
c/Sagasta, 8, 1ª Pl.  
E-28004 Madrid  
Spain

**ERMEC Portugal**  
[portugal@ermec.com](mailto:portugal@ermec.com)

Tel.: (+34)902.450.160  
Fax: (+34)902.433.088  
[info@ermec.com](mailto:info@ermec.com)  
[www.ermec.com](http://www.ermec.com)

[www.apem.com](http://www.apem.com)

# 5000 SERIES - POTENTIOMETER JOYSTICKS

## USEFUL DIMENSIONS

### MOUNTING OPTION A - PANEL CUT-OUT AND MOUNTING INSTALLATION

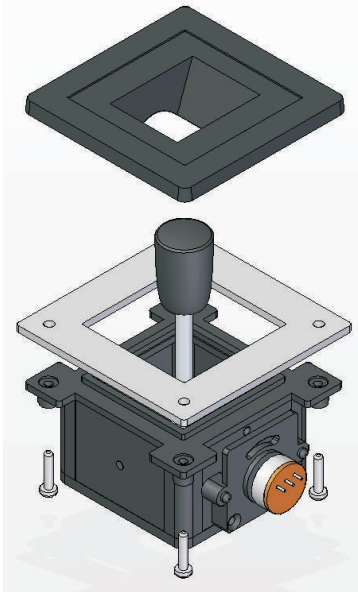

#### MOUNTING CUT-OUT

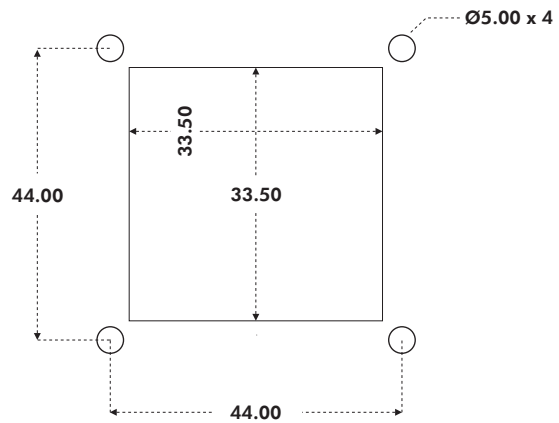

The joystick is mounted from beneath the panel, with the bezel fitted onto the front face of the panel. It is recommended to use No. 2 self tapping, pan head screws, the length of which must be determined subject to the thickness of the panel.

### MOUNTING OPTION B - PANEL CUT-OUT AND MOUNTING INSTALLATION

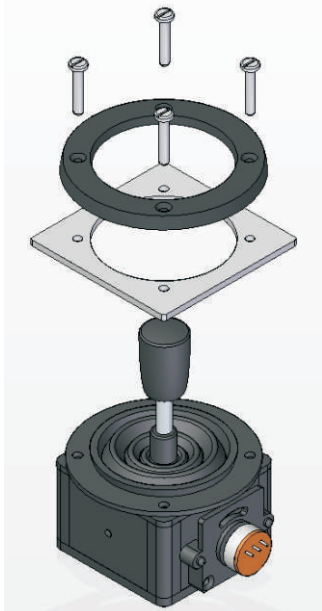

#### MOUNTING CUT-OUT

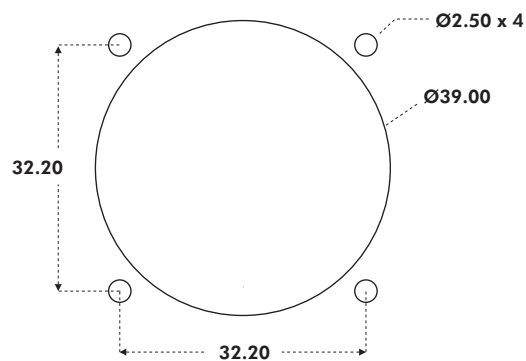

The joystick is mounted from beneath the panel. The gaiter must be passed through the panel cut-out and held in place with the mounting bezel. It is recommended to use No. 2 self tapping countersunk screws, the length of which must be determined subject to the thickness of the panel.

**Note:** During the mounting process, great care should be taken not to damage the gaiter. All panel cut-outs should be free from sharp edges and swarf that may damage the gaiter.

**ERMEC**  
Distribución de componentes eléctricos y electrónicos

ERMEC Barcelona  
c/Francisc Teixidó, 22  
E-08916 Badalona  
Spain

ERMEC Madrid  
c/Sagasta, 8, 1ª Pl.  
E-28004 Madrid  
Spain

ERMEC Portugal  
[portugal@ermec.com](mailto:portugal@ermec.com)

Tel.: (+34)902.450.160  
Fax: (+34)902.433.088  
[info@ermec.com](mailto:info@ermec.com)  
[www.ermec.com](http://www.ermec.com)

[www.apem.com](http://www.apem.com)