

# 1500 series

ermec@ermec.com

## Toggle switches - insulated lever and bushing

*Distinctive features and specifications*



- UL approved
- Variety of actuator styles and colours

### ELECTRICAL SPECIFICATIONS

- Max. current/voltage rating with resistive load : 5A 12VDC (10.000 cycles)
- Initial contact resistance : 10 mΩ max.
- Insulation resistance : 1.000MΩ min. at 500VDC
- Dielectric strength :  
2.000 Vrms 50 Hz min. between terminals and between terminals and metal panel

### MATERIALS

- Case : polyamide
- Actuator : polyamide
- Bushing : polyamide
- Contacts : silver

### GENERAL SPECIFICATIONS

- Torque : 0,95 Nm (.700 Ft.lb) max. applied to nut
- Panel thickness : 4,5 mm (.177) between 2 nuts
- Operating temperature : -20°C to +55°C

### AGENCY APPROVALS



6A 125VAC/250VAC

**Availability** : all models

**Marking** : To order switches marked UL, complete appropriate box of ordering format.

### ABOUT THIS SERIES

**Dimensions** : first dimensions are in mm while inches are shown as bracketed numbers.



**Sealing boots** are available to protect the switches against dust and water. They are presented in section H.



**Mounting accessories** : standard hardware supplied with all models : 1 hex nut U166 and 1 knurled nut U411. Standard and special hardware available are presented in section I.



**Packaging unit** : 50 pieces per type and colour.



www.ermec.com



# 1500 series ermec@ermec.com

## Toggle switches - insulated lever and bushing

Solder lug or quick-connect terminals

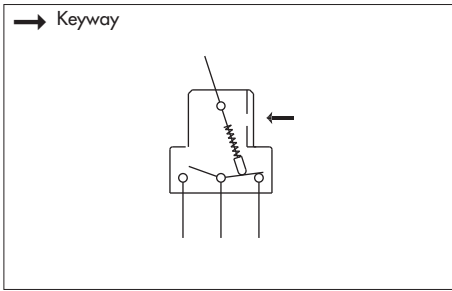

- 2 and 3 maintained positions
- Silver contacts standard
- Single pole configurations

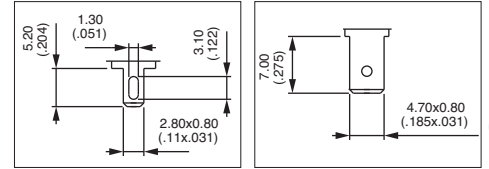

MODEL STRUCTURE



### Solder lug terminals

→ Keyway



1531A2  
1536A2  
1539A2

	I	II	III
1531A2	ON	-	OFF
1536A2	ON	-	ON
1539A2	ON	OFF	ON

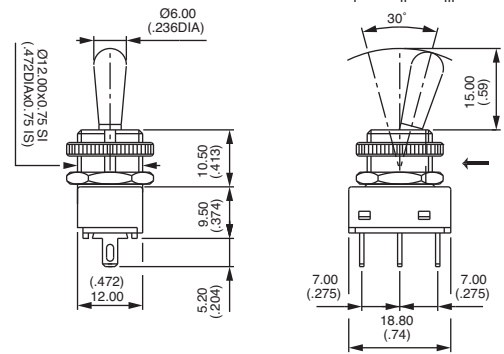

### Quick-connect terminals 4,7 x 0,8 (.185 x .031)

→ Keyway



1531A8  
1536A8  
1539A8

	I	II	III
1531A8	ON	-	OFF
1536A8	ON	-	ON
1539A8	ON	OFF	ON

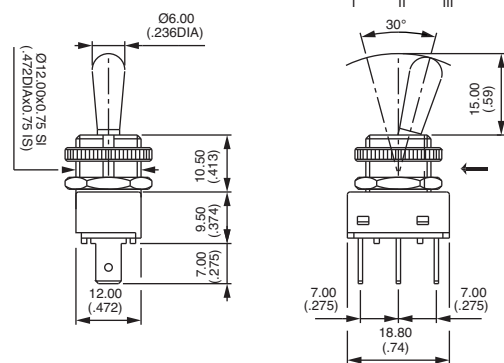

### PANEL CUT-OUT

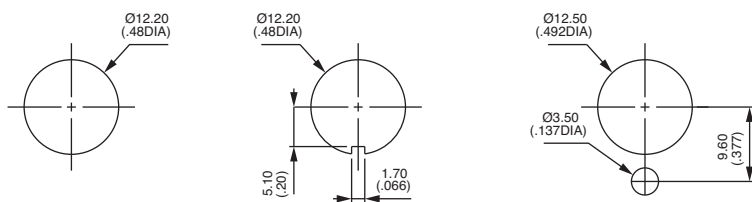

www.ermec.com

# 1500 series

Toggle switches - insulated lever and bushing

## ACTUATORS

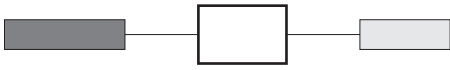

### Polyamide

Black L12  
Red L16  
White L17  
Orange L19

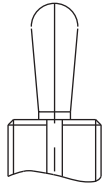

Standard

### Polyamide

Black L22  
Red L26  
White L27  
Orange L29

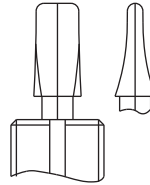

Flat

### Polyamide

Black L32  
Red L36  
White L37  
Orange L39

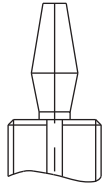

Dual cone

### Polyamide

Black L42  
Red L46  
White L47  
Orange L49

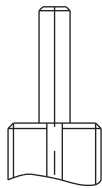

Cylindrical

## AGENCY APPROVALS



UL

Availability : all models.

Marking : to order switches marked UL, complete above box with desired approvals.