

Industrial controls



Section G

	Distinctive features and specifications	G 3
A1	Engraved aluminium flush mounting pushbuttons & indicators - Panel cut-out Ø 22 (.866)	G 5
A01	Pushbutton, rotary lever, keylock & emergency stop switches - Indicators - Panel cut-out Ø 16 (.630)	G 6
A02	Pushbutton, rotary lever, keylock & emergency stop switches - Indicators - Panel cut-out Ø 22 (.866) or 30 (1.181)	G 16
A03	Compact pushbuttons and indicators - Panel cut-out Ø 22 (.866) or 30 (1.181)	G 25

Selection guide

ermec@ermec.com

Industrial controls



Series	A1	A01	A01	A01	A01	A01ES	A01
Type	Pushbutton	Pushbutton	Indicator	Rotary	Keylock	Emergency Stop	Mushroom Head Pushbutton
Page	G-5	G-6	G-7	G-8	G-9	G-10	G-12
Poles	1,2,3,4	1,2,3,4		1,2,3,4	1,2,3,4	1,2	1,2,3,4
Sealing	IP65	IP65	IP65	IP65	IP65	IP65	IP65
Back panel sealing	Option	Option	Option	Option	Option	Option	Option
Illuminated	Yes	Yes	Yes	No	No	No	No
Maximum current	6A 250VAC 6A 12VDC	6A 250VAC 6A 12VDC	6A 250VAC 6A 250VAC	6A 250VAC 6A 12VDC	6A 250VAC 6A 12VDC	1,5A 250VAC AC-15	6A 250VAC 6A 12VDC
Panel cut-out							
Ø16mm		X	X	X	X	X	X
Ø22mm	X	X	X	X	X		X
Flush mounting	Yes	Option	Option	Option	Option	No	Option
Terminal options							
Solder lugs	X	X	X	X	X	X	X
Quick-connect	X	X	X	X	X	X	X
PCB Mounting	Option	Option	Option	Option	Option	Option	Option



Series	A02	A02	A02	A02	A02ES	A02	A03
Type	Pushbutton	Indicator	Rotary	Keylock	Emergency Stop	Mushroom Head Pushbutton	Pushbutton
Page	G-16	G-19	G-20	G-21	G-22	G-23	G-25
Poles	1,2,3,4,n		1,2,3,4,n	1,2,3,4,n	1,2	1,2,3,4	1,2,3,4
Sealing	IP65	IP65	IP65	IP65	IP65	IP65	IP65
Back panel sealing	No	No	No	No	No	No	Option
Illuminated	Yes	Yes	No	No	No	No	Yes
Maximum current	16A 250VAC 12A 12VDC	16A 250VAC 12A 12VDC	16A 250VAC 12A 12VDC	16A 250VAC 12A 12VDC	2,5A 380VAC AC-15	16A 250VAC 12A 12VDC	6A 250VAC 6A 12VDC
Panel cut-out							
Ø22mm	X	X	X	X	X	X	X
Ø30mm	X	X	X	X			X
Flush mounting	Yes	Yes	Option	Option	No	Option	Yes
Terminal options							
Solder lugs							X
Quick-connect	Option	Option	Option	Option	Option	Option	X
Screw	X	X	X	X	X	X	
PCB Mounting	No	No	No	No	No	No	Option



www.ermec.com

A1-A01-A02-A03 series

Industrial controls

Distinctive features

The A01 and A02 series offer ranges of :

- pushbutton switches, illuminated or not
- indicators
- 2 or 3 position keylock switches
- 2 or 3 position rotary lever switches
- emergency stop switches

with rectangular, square or round operators.

New!

- Custom engraved aluminium pushbutton switches, A1 series
- Switch enclosures
- Pushbutton switches and indicators, A03 series

- Environmental protection : IP65
- Modular construction
- Electrical life : 50.000 cycles min.
- Screen engraving or insertable legends on request
- Approvals



BS RIA 20 Shock & Vibration



Each sub-assembly has to be ordered separately.

A01 - A1 - A03 series

- Panel cut-out :
Ø 16 mm (.630), except :
 - flush mount round : Ø 22 mm (.866)
 - flush mount rectangular : 20.60 x 26.70 mm
 - flush mount square : 20.60 x 20.60 mm
 - A1 series : Ø 22 mm (.866)
 - A03 series : round or square Ø 22 (.866)
flush mount : Ø 30 mm (1.378)
- 1, 2, 3 and 4 poles
- Solder lug/quick-connect terminals
- Contacts : silver, gold plated
- Current/voltage rating :
6A 250VAC max. - 10mA 5VAC min.
- Lamp : filament, neon or LED

A02 series

- Panel cut-out :
 - round or square : Ø 22 mm (.866)
 - rectangular : 29,5 x 21,5 mm (1.160x.846)
 - flush mount : Ø 30 mm (1.378)
 - 1 and 2 poles
 - Screw terminals (optional : quick-connect term.)
 - Contacts : silver
 - Current/voltage rating : 12A 380VAC
16A 250VAC max. - 25mA 5VAC min.
 - Lamp : filament, neon, LED
or special multi-LED array
- Option : end cap terminal guard. Order separately (see end of A02 series).

Packaging unit :

A1 : 25 pieces - A01 : 20 pieces (except pushbuttons: 25 pieces) - A02 : 25 pieces - A03 : 10 pieces.

Dimensions : first dimensions are in mm while inches are shown as bracketted numbers.



www.ermec.com

A1-A01-A02-A03 series

Industrial controls

Specifications for pushbutton, keylock and rotary switches

ELECTRICAL SPECIFICATIONS

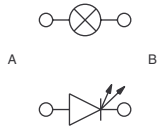
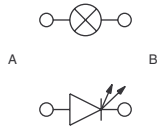
	A01 - A1 - A03	A02
• Function :	Momentary or maintained action	Momentary or maintained action
• Current/voltage rating :	10mA 5VAC min. 6A 250VAC max. - 6A 12VDC max.	25mA 5VAC min. 12A 380VAC - 16A 250VAC max. 12A 12VDC max.
• Contact gap	> 1 mm (.039)	Double break 2 x 1,5 mm (.059)
• Initial contact resistance :	10mΩ max. at 1A 4VDC	10mΩ max. at 1A 4VDC
• Insulation resistance :	50 MΩ min.	50 MΩ min.
• Dielectric strength :	750V between open contacts 5KV live to accessible	2KV between open contacts 4KV live to accessible
• Electrical life (resistive load) :	50.000 cycles	50.000 cycles
• Insulation :	Class 2	Class 2
• Lamp life :	LED : 60.000 h min. to 75% relative luminosity - Filament : approx. 5.000 h Neon : approx. 10.000 h	LED : 60.000 h min. to 75 % relative luminosity - Filament : approx. 5.000 h Neon : approx. 10.000 h
• Lamp circuit diagrams		

GENERAL SPECIFICATIONS

	A01 - A1 - A03	A02
• Min. mechanical life :	Pushb. momentary : 1 million cycles Pushb. maintained : 100.000 cycles Keylock and rotary : 100.000 cycles	Pushb. momentary: 1 million cycles Pushb. maintained : 100.000 cycles Keylock and rotary : 100.000 cycles
• Panel thickness	8 mm (.315) max.	8 mm (.315) max.
• Operating temperature :	-20°C to +55°C	-20°C to +85°C
• Solder heat resistance : (IEC 68-2-20Tb, method 2)	350°C, 5 sec.	350°C, 5 sec.
• Degree of environmental protection (IEC 529)	IP 65 front of panel IP 40 back of panel	IP 65 front of panel IP 40 back of panel
• Lamps :	Midget Grooved T1 _{3/4} , filament, LED or neon	Midget Grooved T1 _{3/4} , filament, LED or neon Special multi-LED array
• Switch terminals :	Solder/quick-connect 2,8 mm (.110)	M3 screws - wire 2 x 0,75 mm ² max.
• Lamp terminals :	Solder/quick-connect 2,8 mm (.110)	M3 screws Flexible wire 2 x 2,5 mm ² max. Rigid wire 4 mm ² max.

Specifications for emergency stop switches : see pages 10 and 22.

For screen engraving or film legends, contact APEM.



www.ermec.com

A01 series

ermec@ermec.com

Illuminated or non-illuminated pushbutton switches

Panel cut-out Ø 16 (.630)

A pushbutton assembly requires :

screen + lamp (if illuminated) + operator + switch block.

To order these elements, select desired model numbers from tables below.

Example : IP65 rectangular pushbutton, single pole, maintained, red screen and 12V red LED = A0161B, A0142M1, A0101X and A0151BUL

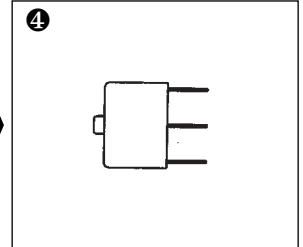
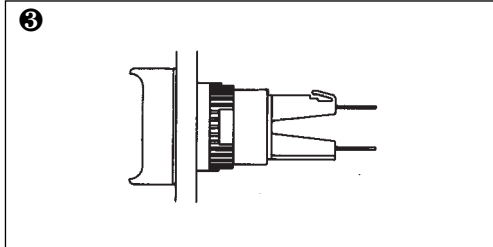
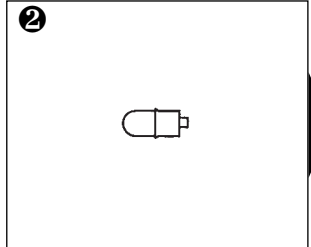
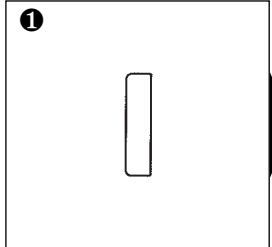
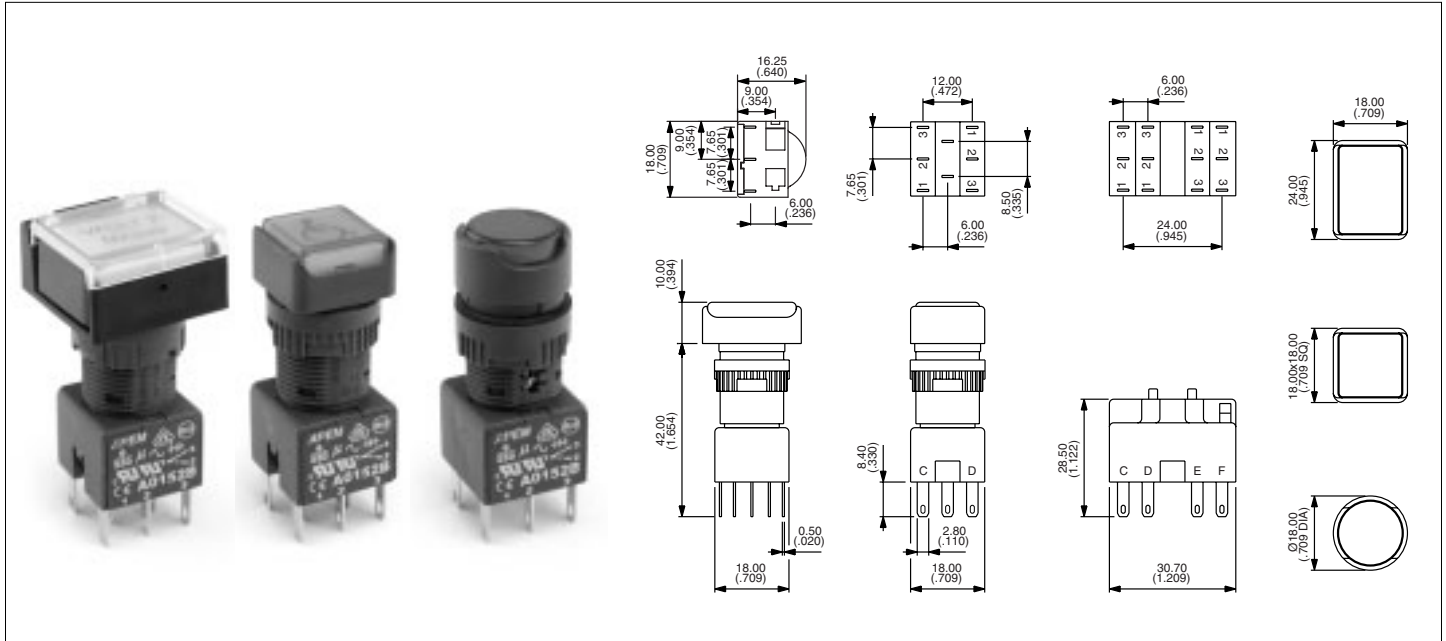
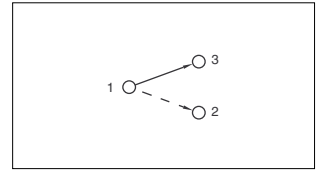

Screen

Bezel	Colour	Part No
□	black	A0161A
□	red	A0161B
□	amber	A0161C
□	yellow	A0161D
□	green	A0161E
□	blue	A0161F
□	clear	A0161G
□	white	A0161J
□	black	A0162A
□	red	A0162B
□	amber	A0162C
□	yellow	A0162D
□	green	A0162E
□	blue	A0162F
□	clear	A0162G
□	white	A0162J
○	black	A0163A
○	red	A0163B
○	amber	A0163C
○	yellow	A0163D
○	green	A0163E
○	blue	A0163F
○	clear	A0163G
○	white	A0163J

Lamp

Lamp	Voltage	Part No
Filament	6.3V	A0141A
Filament	14V	A0141B
Filament	28V	A0141C
Filament	36V	A0141D
Filament	48V	A0141E
Filament	60V	A0141F
Neon	110V	A0143G
Neon	220V	A0143H
LED	6V red	A0142L1
LED	6V green	A0142L2
LED	6V amber	A0142L3
LED	12V red	A0142M1
LED	12V green	A0142M2
LED	12V amber	A0142M3
LED	12V blue	A0142M4
LED	12V white	A0142M5
LED	24V red	A0142N1
LED	24V green	A0142N2
LED	24V amber	A0142N3
LED	24V blue	A0142N4
LED	24V white	A0142N5
LED	48V red	A0142P1
LED	48V green	A0142P2
LED	48V amber	A0142P3

Operator

Pole	Bezel	Description	Part No
1 or 2	□	illum, momentary	A0101Y
1 or 2	□	illum, maintained	A0101X
1 or 2	□	Non-illum, momentary	A0102Y
1 or 2	□	Non-illum, maintained	A0102X
3 or 4	□	illum, momentary	A0103Y
3 or 4	□	illum, maintained	A0103X
3 or 4	□	Non-illum, momentary	A0104Y
3 or 4	□	Non-illum, maintained	A0104X
1 or 2	□	illum, momentary	A0105Y
1 or 2	□	illum, maintained	A0105X
1 or 2	□	Non-illum, momentary	A0106Y
1 or 2	□	Non-illum, maintained	A0106X
3 or 4	□	illum, momentary	A0107Y
3 or 4	□	illum, maintained	A0107X
3 or 4	□	Non-illum, momentary	A0108Y
3 or 4	□	Non-illum, maintained	A0108X
1 or 2	○	illum, momentary	A0109Y
1 or 2	○	illum, maintained	A0109X
1 or 2	○	Non-illum, momentary	A0110Y
1 or 2	○	Non-illum, maintained	A0110X
3 or 4	○	illum, momentary	A0111Y
3 or 4	○	illum, maintained	A0111X
3 or 4	○	Non-illum, momentary	A0112Y
3 or 4	○	Non-illum, maintained	A0112X

Switch block

No of poles	Part No
Single pole	A0151BUL
Double pole	A0152BUL
Three pole	A0155BUL
Four pole	A0153BUL

UNSEALED SWITCHES (IP40) : add "01" to end of operator model number.

BI-COLOUR LED's optional.

SCREEN ENGRAVING/INSERTABLE LEGENDS : contact APEM

Bezel: □ rectangular, □ square, ○ round, 'illum' - illuminated, 'Non-illum' - non illuminated



www.ermec.com

A01 series

Indicators

Panel cut-out Ø 16 (.630)

An indicator assembly requires :

screen + lamp + operator.

To order these elements, select desired model numbers from tables below.

Example : IP65 rectangular indicator with red screen and 12V red LED = A0161B, A0142M1 and A0171.

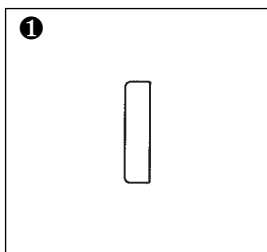
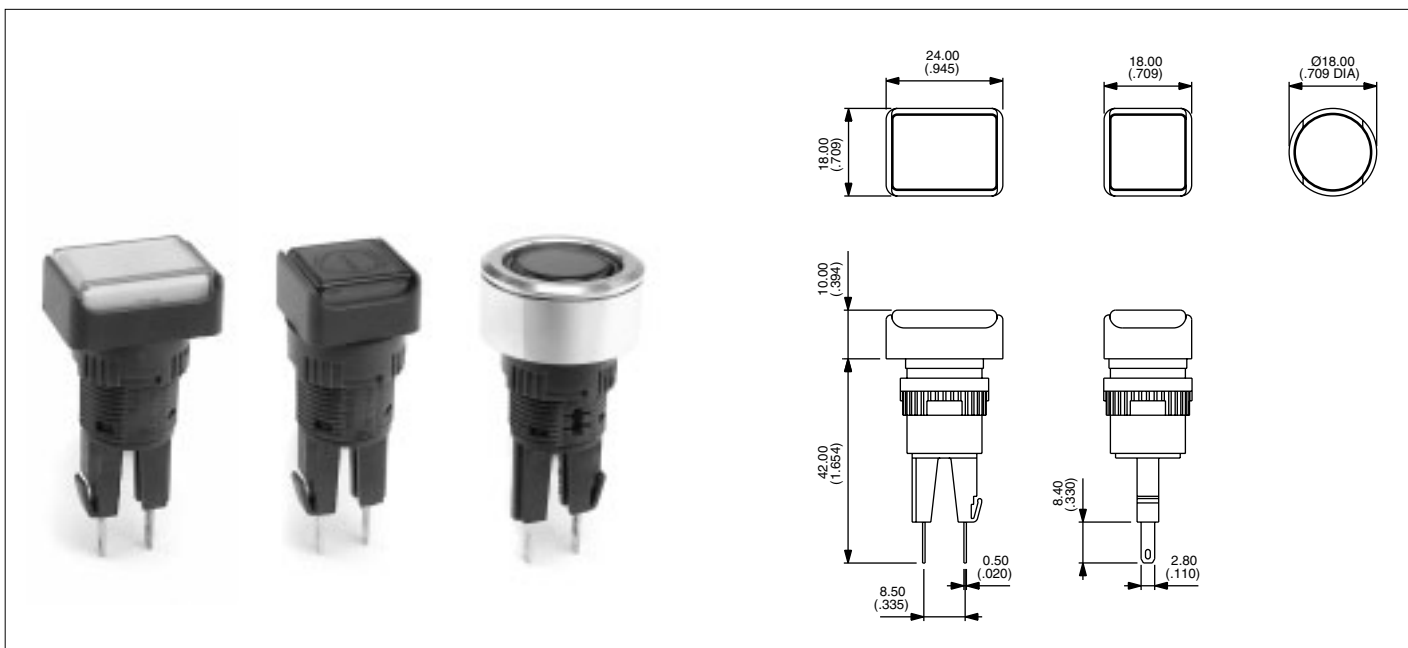

Screen

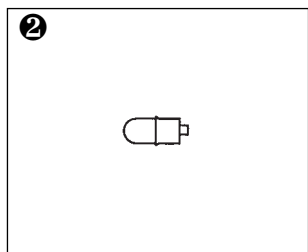

Lamp

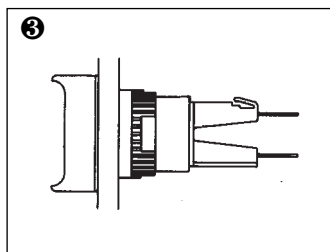

Operator

Bezel	Colour	Part No
□	black	A0161A
□	red	A0161B
□	amber	A0161C
□	yellow	A0161D
□	green	A0161E
□	blue	A0161F
□	clear	A0161G
□	white	A0161J
□	black	A0162A
□	red	A0162B
□	amber	A0162C
□	yellow	A0162D
□	green	A0162E
□	blue	A0162F
□	clear	A0162G
□	white	A0162J
○	black	A0163A
○	red	A0163B
○	amber	A0163C
○	yellow	A0163D
○	green	A0163E
○	blue	A0163F
○	clear	A0163G
○	white	A0163J

Lamp	Voltage	Part No
Filament	6.3V	A0141A
Filament	14V	A0141B
Filament	28V	A0141C
Filament	36V	A0141D
Filament	48V	A0141E
Filament	60V	A0141F
Neon	110V	A0143G
Neon	220V	A0143H
LED	6V red	A0142L1
LED	6V green	A0142L2
LED	6V amber	A0142L3
LED	12V red	A0142M1
LED	12V green	A0142M2
LED	12V amber	A0142M3
LED	12V blue	A0142M4
LED	12V white	A0142M5
LED	24V red	A0142N1
LED	24V green	A0142N2
LED	24V amber	A0142N3
LED	24V blue	A0142N4
LED	24V white	A0142N5
LED	48V red	A0142P1
LED	48V green	A0142P2
LED	48V amber	A0142P3

Bezel	Description	Part No
□	Indicator	A0171
□	Indicator	A0172
○	Indicator	A0173

UNSEALED INDICATORS (IP40) :
add "01" to end of operator model number.

SCREEN ENGRAVING / INSERTABLE LEGENDS : contact APEM

Bezel: □ rectangular, □ square, ○ round



www.ermec.com

A01 series

ermec@ermec.com

Rotary lever switches

Panel cut-out Ø 16 (.630)

A rotary lever switch assembly requires :
operator + switch block.

To order these elements, select desired model numbers from tables below.

Example : IP65 rectangular rotary switch with long lever, clockwise rotation, single pole, 2 positions, maintained = A019109 and A0151BUL.

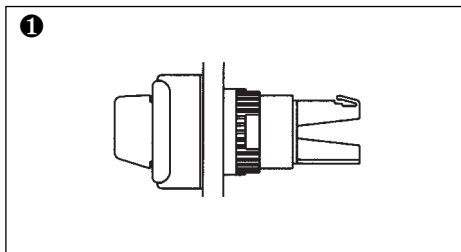
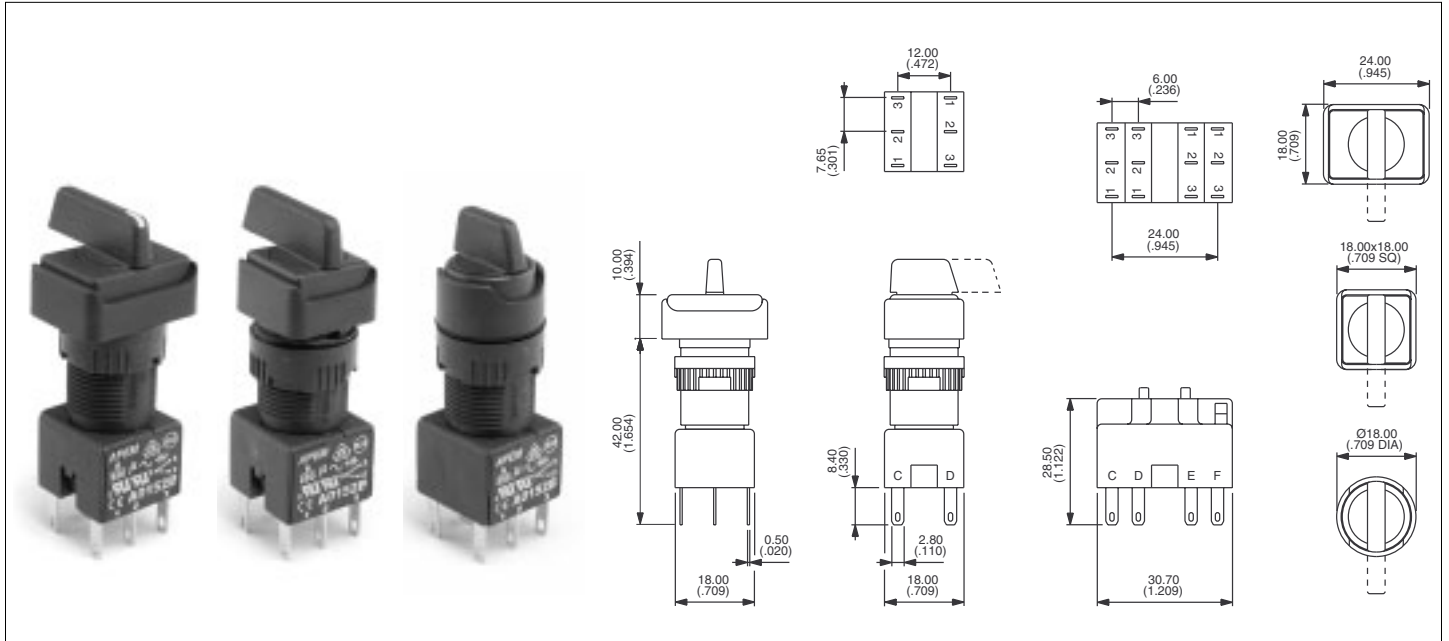
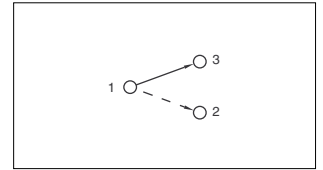

Operator

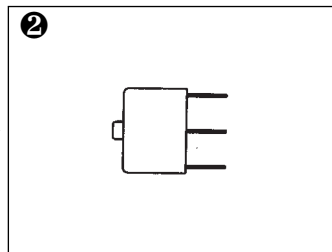

Switch block

Lever Positions

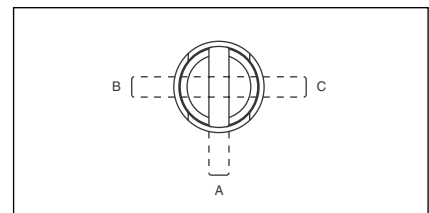

• Lever Rotation - 2 position switches

The model numbers shown are for switches with clockwise lever rotation.

For anticlockwise rotation, replace :

09	with	01
10	with	02
11	with	03
12	with	04

at the end of the model number.

Optional Engraving on Lever end

See above photo left.

To order, add "WL" to the end of the operator part No.

Example : A019609WL..

Pole	Bezel	Description	Short lever	Long lever	No of poles	Description	Part No
1 or 2	□	2 pos. maintained	A019209	A019109•	Single pole		A0151BUL
1 or 2	□	2 pos. momentary	A019210	A019110•	Double pole		A0152BUL
3 or 4	□	2 pos. maintained	A019211	A019111•	Three pole		A0155BUL
3 or 4	□	2 pos. momentary	A019212	A019112•	Four pole		A0153BUL
1 or 2	□	3 pos. maintained	A019205	A019105			
1 or 2	□	3 pos. momentary	A019206	A019106			
1 or 2	□	3 pos. mainL, momR	A019207	A019107			
1 or 2	□	3 pos. momL, mainR	A019208	A019108			
1 or 2	□	2 pos. maintained	A019409	A019309•			
1 or 2	□	2 pos. momentary	A019410	A019310•			
3 or 4	□	2 pos. maintained	A019411	A019311•			
3 or 4	□	2 pos. momentary	A019412	A019312•			
1 or 2	□	3 pos. maintained	A019405	A019305			
1 or 2	□	3 pos. momentary	A019406	A019306			
1 or 2	□	3 pos. mainL, momR	A019407	A019307			
1 or 2	□	3 pos. momL, mainR	A019408	A019308			
1 or 2	○	2 pos. maintained	A019609	A019509•			
1 or 2	○	2 pos. momentary	A019610	A019510•			
3 or 4	○	2 pos. maintained	A019611	A019511•			
3 or 4	○	2 pos. momentary	A019612	A019512•			
1 or 2	○	3 pos. maintained	A019605	A019505			
1 or 2	○	3 pos. momentary	A019606	A019506			
1 or 2	○	3 pos. mainL, momR	A019607	A019507			
1 or 2	○	3 pos. momL, mainR	A019608	A019508			

Bezel: □ rectangular, □ square, ○ round, 'pos' - position, 'mainL' - maintained left, 'momR' - momentary right, etc



www.ermec.com

A01 series

Keylock switches

Panel cut-out Ø 16 (.630)

A keylock switch assembly requires :

operator + switch block.

To order these elements, select desired model numbers from tables below.

Example : IP65 rectangular keyswitch, clockwise rotation, single pole, 2 positions, maintained = A018125 and A0151BUL.

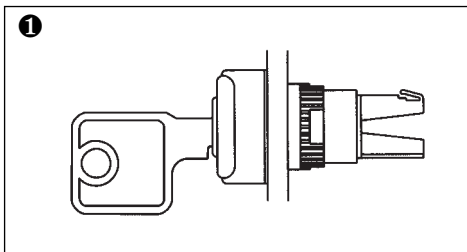
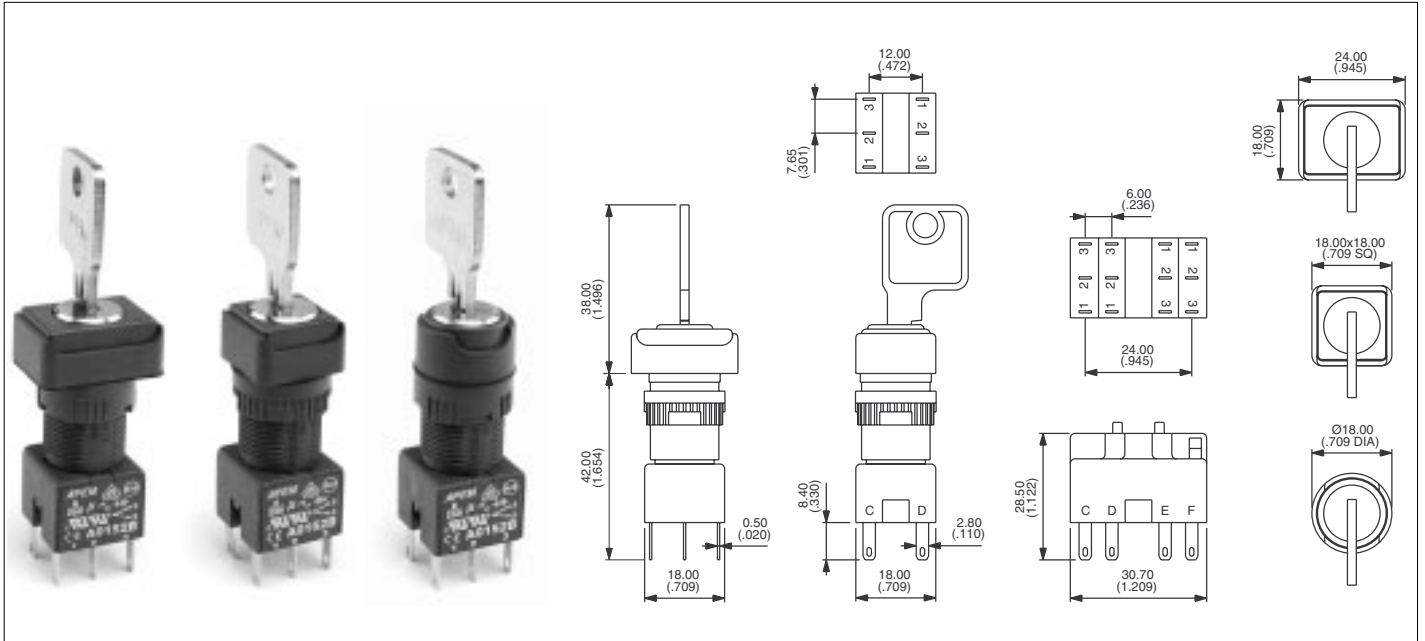
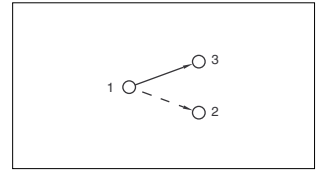

Operator

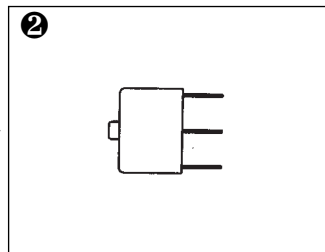

Switch block

Key Positions

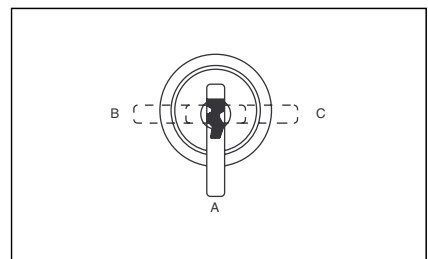

Pole	Bezel	Description	Part No	Key removable	No of poles	Part No
1 or 2	□	2 pos. maintained	A018123	A	Single pole	A0151BUL
1 or 2	□	2 pos. maintained	A018125	A-B	Double pole	A0152BUL
1 or 2	□	2 pos. momentary	A018124	A	Three pole	A0155BUL
3 or 4	□	2 pos. maintained	A018127	A-B	Four pole	A0153BUL
3 or 4	□	2 pos. momentary	A018128	A		
1 or 2	□	3 pos. maintained	A018105	A-B-C		
1 or 2	□	3 pos. momentary	A018106	A		
1 or 2	□	3 pos. mainL, momR	A018107	A-B		
1 or 2	□	3 pos. momL, mainR	A018108	A-C		
1 or 2	□	2 pos. maintained	A018223	A		
1 or 2	□	2 pos. maintained	A018225	A-B		
1 or 2	□	2 pos. momentary	A018224	A		
3 or 4	□	2 pos. maintained	A018227	A-B		
3 or 4	□	2 pos. momentary	A018228	A		
1 or 2	□	3 pos. maintained	A018205	A-B-C		
1 or 2	□	3 pos. momentary	A018206	A		
1 or 2	□	3 pos. mainL, momR	A018207	A-B		
1 or 2	□	3 pos. momL, mainR	A018208	A-C		
1 or 2	○	2 pos. maintained	A018323	A		
1 or 2	○	2 pos. maintained	A018325	A-B		
1 or 2	○	2 pos. momentary	A018324	A		
3 or 4	○	2 pos. maintained	A018327	A-B		
3 or 4	○	2 pos. momentary	A018328	A		
1 or 2	○	3 pos. maintained	A018305	A-B-C		
1 or 2	○	3 pos. momentary	A018306	A		
1 or 2	○	3 pos. mainL, momR	A018307	A-B		
1 or 2	○	3 pos. momL, mainR	A018308	A-C		

• Key Rotation - 2 position switches

The model numbers shown are for switches with clockwise key rotation.

For anticlockwise rotation, replace :

25	with	01
24	with	02
27	with	03
28	with	04

at the end of the model number.

2 standard keys are supplied.

20 key barrel types available from stock.

NON-REMOVABLE KEY POSITIONS / ON-ON-ON FUNCTION : contact APEM.



Bezel: □ rectangular, □ square, ○ round,

'pos' - position, 'mainL' - maintained left, 'momR' - momentary right, etc

www.ermec.com

A01 series

ermec@ermec.com

Emergency stop switches

Panel cut-out Ø 16 (.630)

- Prominent 24 mm (.944) dia. or optional 40 mm (1.575) dia. red mushroom actuator
- Highly reliable positive break switch
- Push to shut off switch, twist to reset to ON
- Approved to UL 1054 / EN 60947-5-1

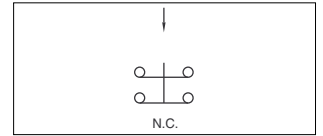

An emergency stop switch assembly requires : operator + switch block.
To order, specify with single pole or double pole positive break switch block.

General specifications

- Min. mechanical life : 6.050 cycles (6 cycles per minute)
- Operating force / torque : 16 N / 0,1 Nm
- Operating temperature : -20°C to +55°C
- Solder heat resistance : 350°C, 5 secs (IEC 68-2-2-20Tb, method 2)
- Degree of environmental protection (IEC 529) : IP65 front of panel, IP40 back of panel
- Switch terminals : solder/quick-connect 2,8 mm (.110) (IEC 68-2-20)

Electrical specifications

- Current/voltage rating : 1,5A 250VAC AC-15
- Contact gap : > 3 mm (.118)
- Dielectric strength : 2.900V
- Electrical life : 6.050 cycles

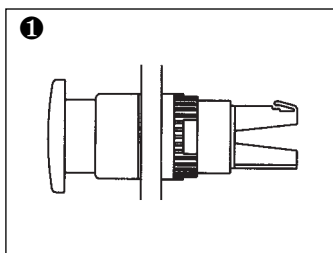
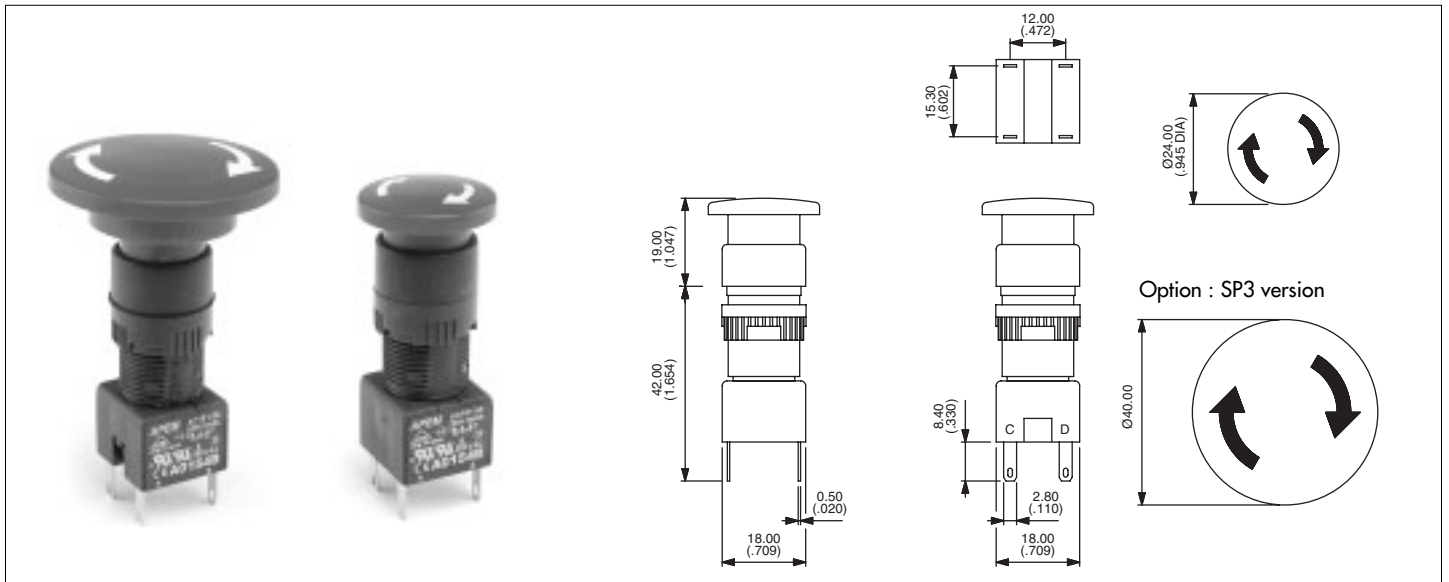

Operator

Description	Part No
24 mm Ø Emergency stop	A01ES
40 mm Ø Emergency stop	A01ES SP3

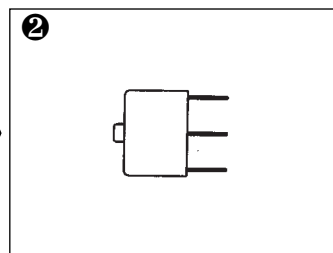

Switch block

No of poles	Part No
Single pole	A0150BUL
Double pole	A0154BUL

Accessory



60 mm Ø Self Adhesive Label

Description	Part No
Yellow label with text	A01YL1
Yellow label	A01YL2



www.ermec.com

A01 series

Emergency stop switches/mushroom head pushbutton switches

Fitted in enclosures

- Prominent 40 mm (1.575) dia. mushroom actuator, twist to release
- Highly reliable positive break switching on E-Stop
- Sealed to IP65
- 6A current rating
- Robust polycarbonate enclosures
- Knockouts for popular conduit sizes
- Double pole changeover switch blocks available for momentary/maintained mushroom head pushbuttons.

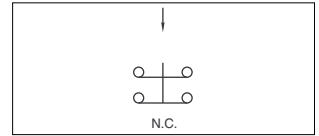

Emergency stop

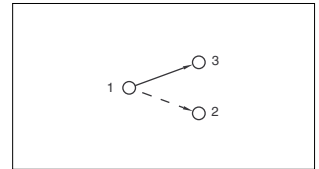

Momentary & maintained

Technical specifications

- Contact rating : Pushbutton switch : 6A 250VAC - E-Stop : 1,5A 250VAC
- Dimensions : 65 x 65 x 57 mm
- Electrical life : Pushbutton switch : 50 000 cycles - E-Stop : 6 050 cycles
- Operating temperature : -20°C to +55°C



Description	Part No
Emergency stop	A01ESSP354B + PEA01
Black momentary	A01MMASP352B + PEA01
Red momentary	A01MMBSP352B + PEA01
Yellow momentary	A01MMDSP352B + PEA01
Green momentary	A01MMESP352B + PEA01
Blue momentary	A01MMFSP352B + PEA01
Black maintained	A01MXASP352B + PEA01
Red maintained	A01MXBSP352B + PEA01
Yellow maintained	A01MXDSP352B + PEA01
Green maintained	A01MXESP352B + PEA01
Blue maintained	A01MXFSP352B + PEA01

OPTIONS

12A 250V versions or custom printing on mushroom head actuators : contact APEM.



www.ermec.com

A01 series

ermec@ermec.com

Mushroom head pushbutton switches

Panel cut-out Ø 16 (.630)

- Prominent 24 mm (.944) dia. or optional 40 mm (1.575) dia. mushroom actuators
- Momentary and maintained functions
Momentary function versions are unmarked.
Maintained function versions are twist release (arrows indicate direction of twist)
- Various coloured mushroom actuators are available.

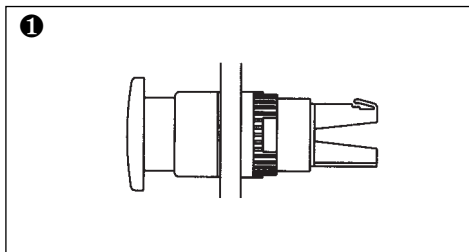
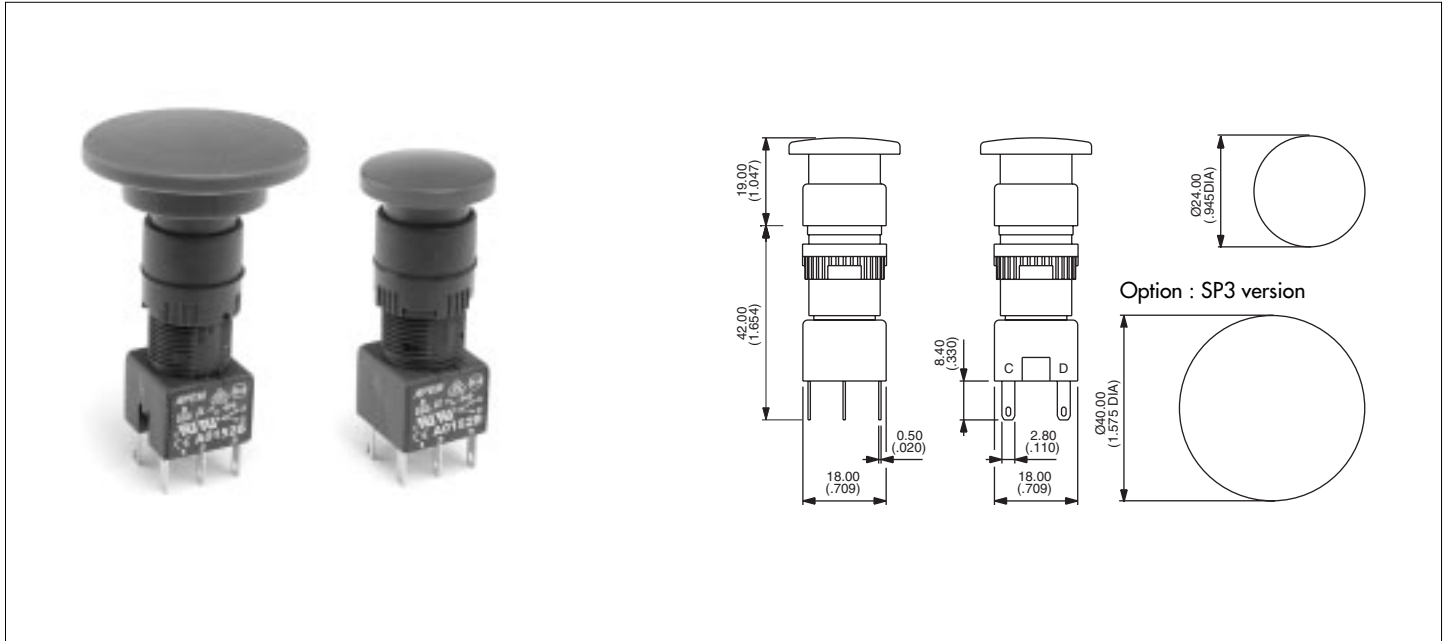
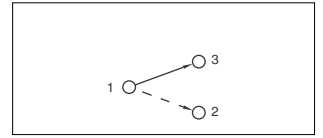

Operator

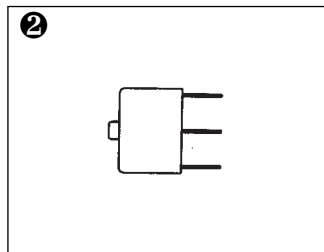

Switch block

Actuator	Description	Part No	No of poles	Part No
24mmØ	Black momentary	A01MMA	Single pole	A0151BUL
24mmØ	Red momentary	A01MMB	Double pole	A0152BUL
24mmØ	Yellow momentary	A01MMD	Three pole	A0155BUL
24mmØ	Green momentary	A01MME	Four pole	A0153BUL
24mmØ	Blue momentary	A01MMF		
24mmØ	Black maintained	A01MXA		
24mmØ	Red maintained	A01MXB		
24mmØ	Yellow maintained	A01MXD		
24mmØ	Green maintained	A01MXE		
24mmØ	Blue maintained	A01MXF		
40mmØ	Black momentary	A01MMA SP3		
40mmØ	Red momentary	A01MMB SP3		
40mmØ	Yellow momentary	A01MMD SP3		
40mmØ	Green momentary	A01MME SP3		
40mmØ	Blue momentary	A01MMF SP3		
40mmØ	Black maintained	A01MXA SP3		
40mmØ	Red maintained	A01MXB SP3		
40mmØ	Yellow maintained	A01MXD SP3		
40mmØ	Green maintained	A01MXE SP3		
40mmØ	Blue maintained	A01MXF SP3		



www.ermec.com

A1-A01 series

Industrial controls

Accessories

FLUSH MOUNTING BEZELS

Dark grey plastic material - supplied with sealing washer

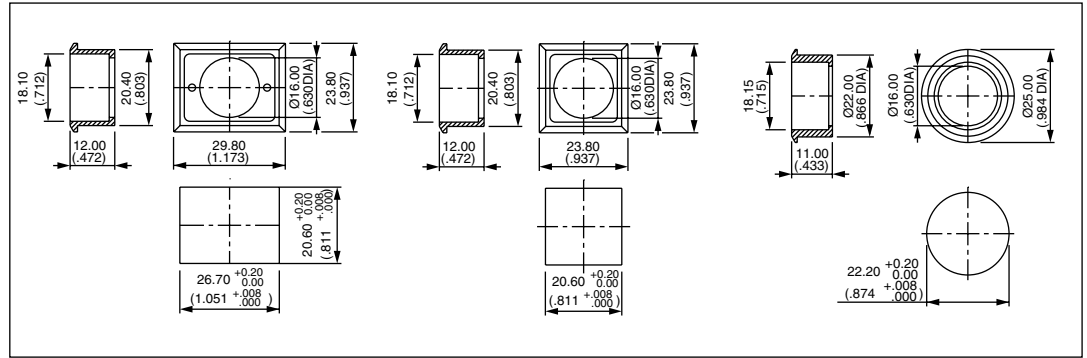

Rectangular **A01FM1**

Square **A01FM**

Round **A01FM2**

FLUSH MOUNTING BEZELS

Metal versions

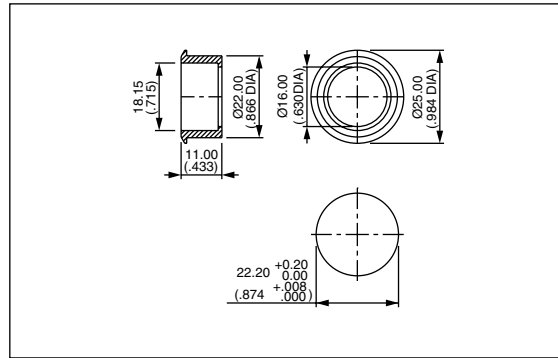

Round, anodised aluminium **A01FMM**

Round, matt black **A01FMMG**

PCB SOCKET

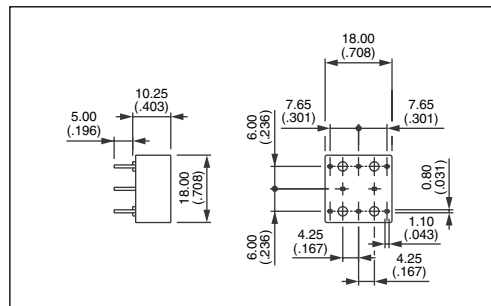

- Single pole, non illuminated **A01PC1**
- Double pole, non illuminated **A01PC2**
- Single pole, illuminated **A01PC3**
- Double pole, illuminated **A01PC4**
- Indicator **A01PC5**
- Single pole, E-stop **A01PC6**
- Double pole, E-stop **A01PC7**

FLAPGUARDS

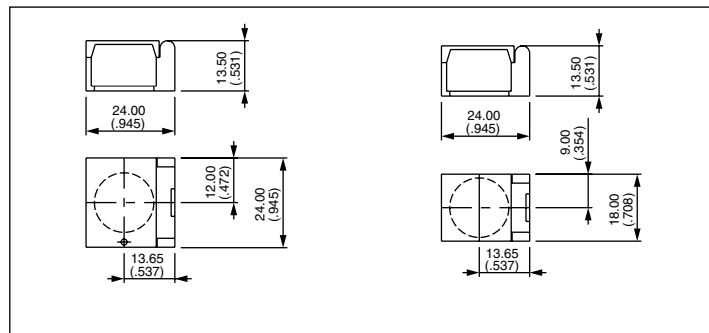

Rectangular **A01FG1**

Square/round **A01FG2**



www.ermec.com

A1-A01 series

ermec@ermec.com

Industrial controls

Accessories

METAL GUARDS

→ Slot as alternative to Ø 2 mm hole - Material : 1 mm thick aluminium.

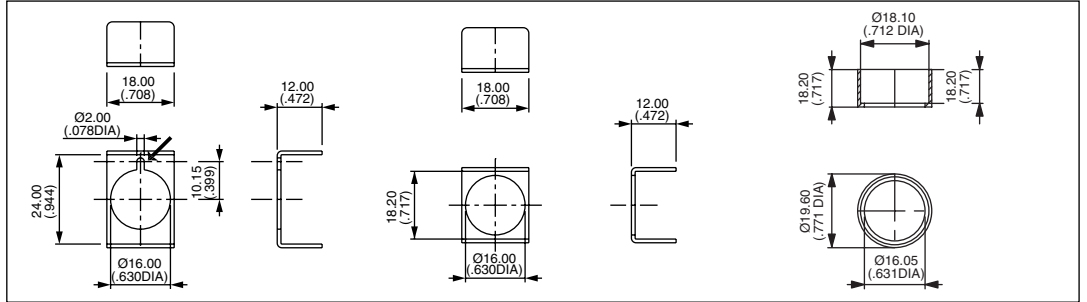
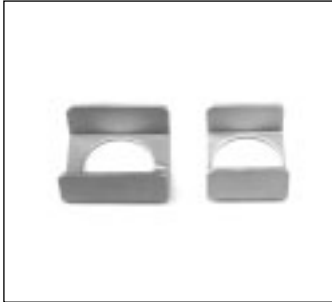

Rectangular **A01MG1**

Square **A01MG**

Round, natural **A01MG2**
Matt black **A01MG2G**

ANTI ROTATION RING

Recommended to prevent product rotation

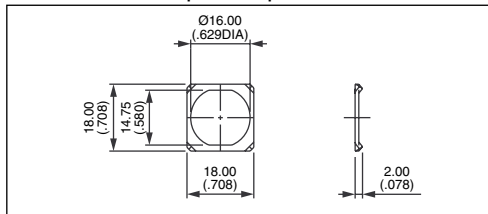
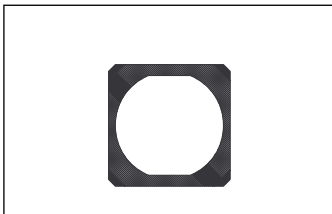

A01LW

SWITCHBLOCK TERMINAL GUARDS

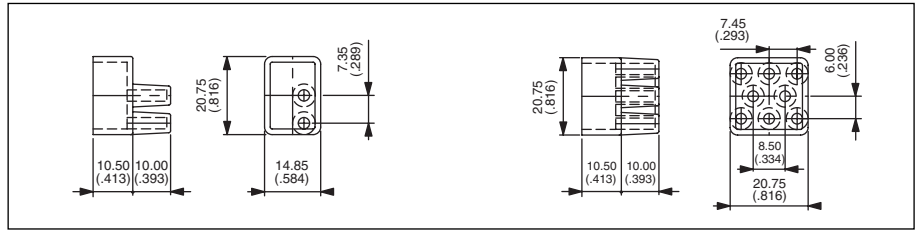

2 way **A01RTC2**

8 way **A01RTC8**

BLANKING PLUGS

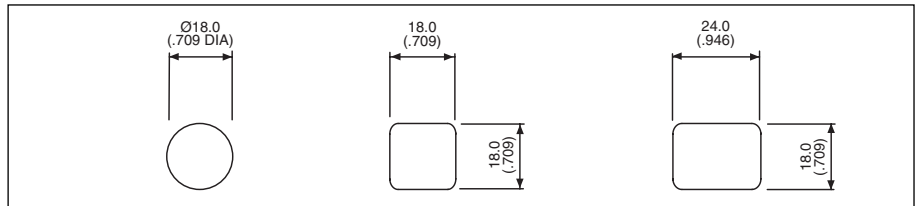

Round **A0133**

Square **A0132**

Rectangular **A0131**

RESISTOR ASSEMBLY

Resistor assembly - 2 stage illumination

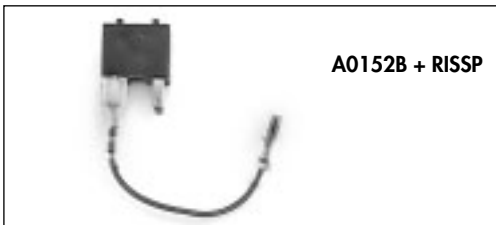

A0152B + RISSP

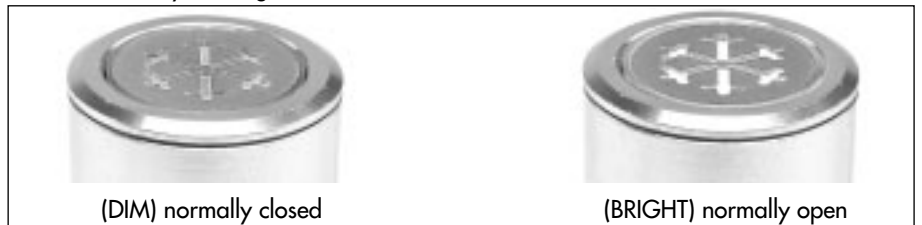

(DIM) normally closed

(BRIGHT) normally open

G



www.ermec.com

Modular construction / panel mounting

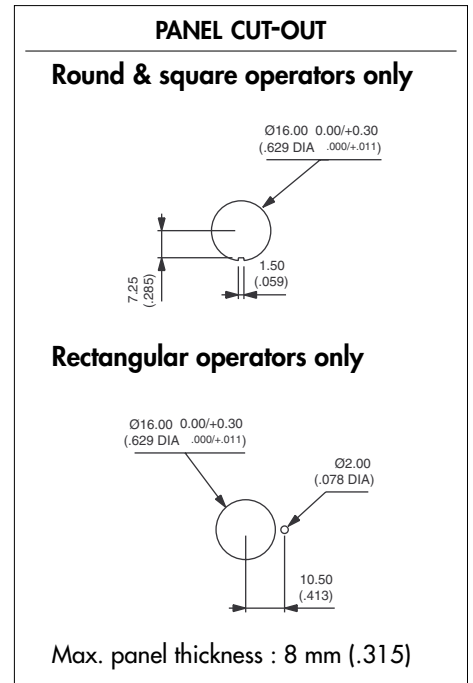
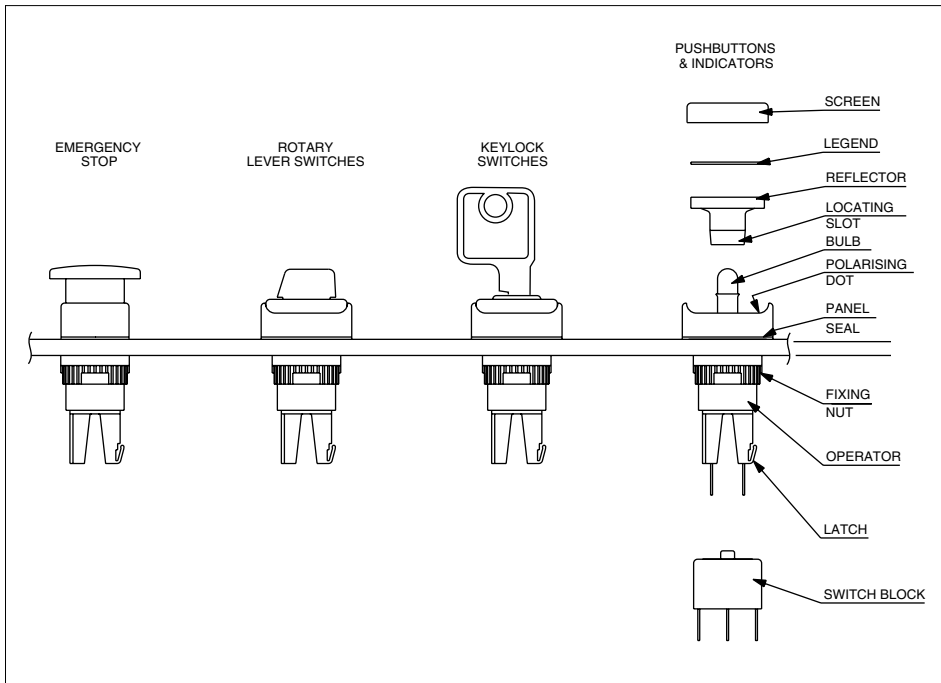

PANEL MOUNTING ASSEMBLY

- Drill/punch hole shaped as above.
- Assemble front operator through hole, fit fixing nut and tighten to a maximum torque of 0,8Nm using tool No 30-0001.
- Wire chosen switch block as required and slide onto operator until latch engages.
- Fit bulb if required using tool No 30-0002.
- Snap screen onto reflector assembly with legend in between if required and snap onto front operator TAKING CARE TO LINE UP THE LOCATING SLOT WITH THE POLARISING DOT, and not to damage the seal.

TO REMOVE BULB

Remove reflector/screen assembly. Use the bulb extractor 30-0002 to remove the bulb.

SWITCH BLOCK

To assemble switch block to front operator, TAKE CARE TO LINE UP SWITCH BLOCK WITH FRONT OPERATOR. Once in position, slide on to front operator. NB. : Ensure latch is fully engaged correctly onto the switch block.

To remove switch block, depress the latch and slide the switch block off the operator.

FIXING NUT KEY



BULB REMOVER



A02 series

ermec@ermec.com

Illuminated or non-illuminated pushbutton switches

Panel cut-out \varnothing 22 (.866) or 29,5 x 21,5 (1.160x.846)

A pushbutton assembly requires :

screen + lamp (if illuminated) + operator + one or two switch blocks.

To order these elements, select desired model numbers from tables below.

Example : IP65 illuminated rectangular maintained pushbutton, switch block with 2 N.O. contacts, red screen and 12V red LED assembly = A0261B, A0242J1, A0201X and A02503UL.

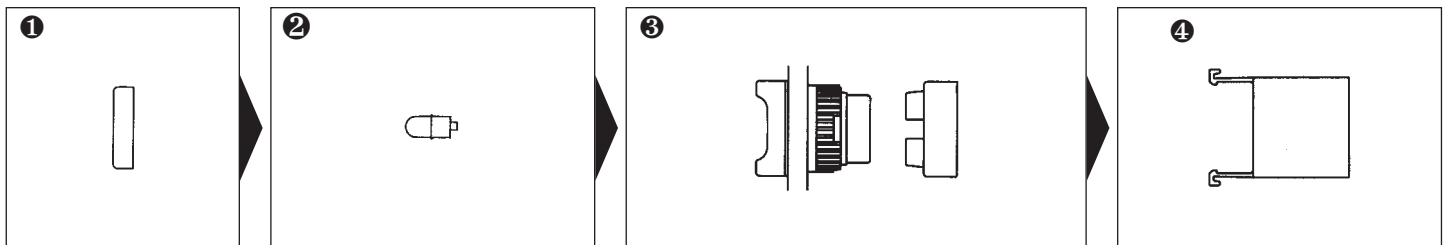
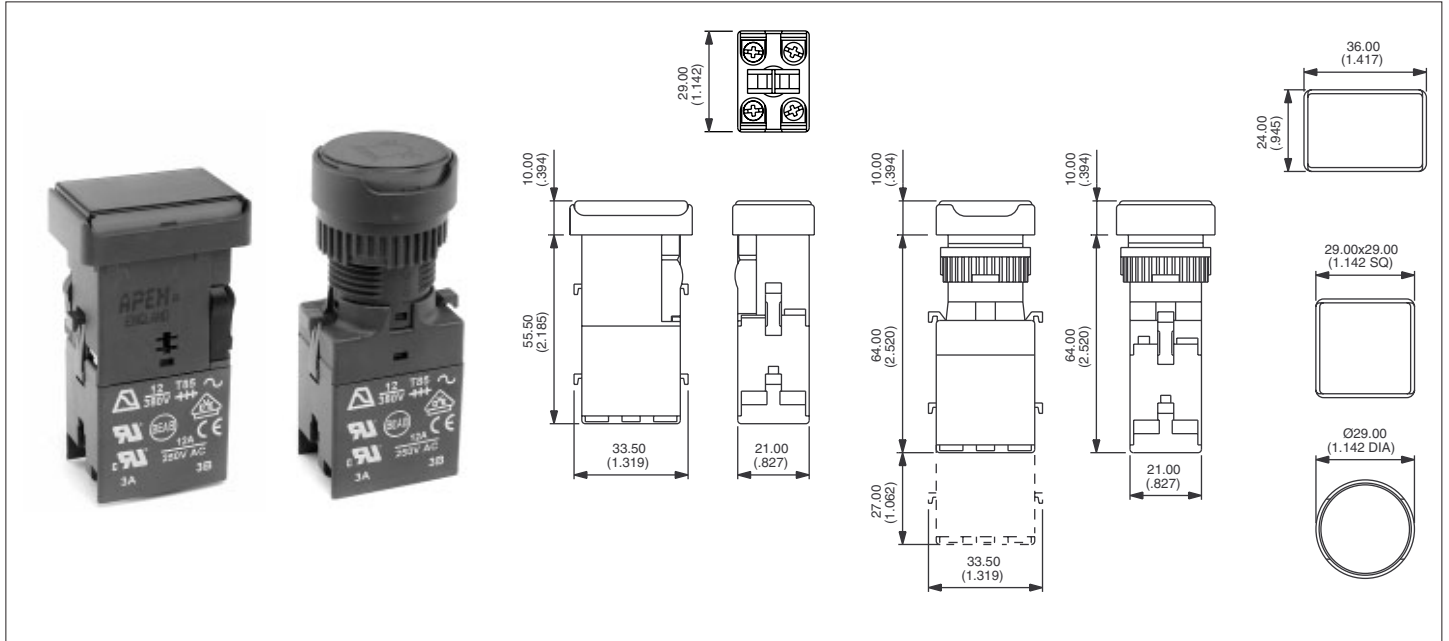
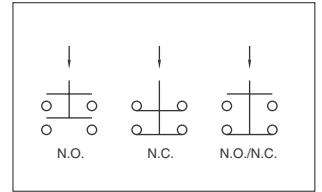

Screen

Lamp

Operator

Switch block

Bezel	Colour	Part No	Lamp	Voltage	Part No	Bezel	Description	Lamp type	Part No	Contacts	Part No
<input type="checkbox"/>	black	A0261A	Filament	6.3V	A0141A	<input type="checkbox"/>	illum, momentary	Lamp/LED	A0201Y	1 N.O.	A02501UL
<input type="checkbox"/>	red	A0261B	Filament	14V	A0141B	<input type="checkbox"/>	illum, maintained	Lamp/LED	A0201X	1 N.C.	A02502UL
<input type="checkbox"/>	amber	A0261C	Filament	28V	A0141C	<input type="checkbox"/>	illum, momentary	LED assy	A0202Y	2 N.O.	A02503UL
<input type="checkbox"/>	yellow	A0261D	Filament	36V	A0141D	<input type="checkbox"/>	illum, maintained	LED assy	A0202X	2 N.C.	A02504UL
<input type="checkbox"/>	green	A0261E	Filament	48V	A0141E	<input type="checkbox"/>	Non-illum, maintained		A0203X	1 N.O./1 N.C.	A02505UL
<input type="checkbox"/>	blue	A0261F	Filament	60V	A0141F	<input type="checkbox"/>	Non-illum, momentary		A0203Y		
<input type="checkbox"/>	clear	A0261G	Neon	110V	A0143G	<input type="checkbox"/>	illum, momentary	Lamp/LED	A0204Y		
<input type="checkbox"/>	white	A0261J	Neon	220V	A0143H	<input type="checkbox"/>	illum, maintained	Lamp/LED	A0204X		
<input type="checkbox"/>	black	A0262A	LED	model numbers: see A01 pages G6-G7.		<input type="checkbox"/>	illum, momentary	LED assy	A0205Y		
<input type="checkbox"/>	red	A0262B				<input type="checkbox"/>	illum, maintained	LED assy	A0205X		
<input type="checkbox"/>	amber	A0262C	LED assy	6V	A0242H*	<input type="checkbox"/>	Non-illum, momentary		A0206Y		
<input type="checkbox"/>	yellow	A0262D	LED assy	12V	A0242J*	<input type="checkbox"/>	Non-illum, maintained		A0206X		
<input type="checkbox"/>	green	A0262E	LED assy	24V	A0242K*	<input type="checkbox"/>	illum, momentary	Lamp/LED	A0207Y	1 N.O.	A02506UL
<input type="checkbox"/>	blue	A0262F	LED assy	6V	A0243H*	<input type="checkbox"/>	illum, maintained	Lamp/LED	A0207X	1 N.C.	A02507UL
<input type="checkbox"/>	clear	A0262G	LED assy	12V	A0243J*	<input type="checkbox"/>	illum, momentary	LED assy	A0208Y	2 N.O.	A02508UL
<input type="checkbox"/>	white	A0262J	LED assy	24V	A0243K*	<input type="checkbox"/>	illum, maintained	LED assy	A0208X	2 N.C.	A02509UL
<input type="checkbox"/>	black	A0263A	LED assy	6V	A0244H*	<input type="checkbox"/>	Non-illum, momentary		A0209Y	1 N.O./1 N.C.	A02510UL
<input type="checkbox"/>	red	A0263B	LED assy	12V	A0244J*	<input type="checkbox"/>	Non-illum, maintained		A0209X		
<input type="checkbox"/>	amber	A0263C	LED assy	24V	A0244K*						
<input type="checkbox"/>	yellow	A0263D									
<input type="checkbox"/>	green	A0263E	Replace * with colour code		1: red						
<input type="checkbox"/>	blue	A0263F	for LED assemblies:		2: green						
<input type="checkbox"/>	clear	A0263G			3: amber						
<input type="checkbox"/>	white	A0263J									

Second switch block

Contacts	Part No
1 N.O.	A02506UL
1 N.C.	A02507UL
2 N.O.	A02508UL
2 N.C.	A02509UL
1 N.O./1 N.C.	A02510UL

To achieve 3 or 4 pole switching, add second switch block, from above table.

White or blue LED assembly : contact APEM.

UNSEALED SWITCHES (IP40) :

add "01" to end of operator model number.

SCREEN ENGRAVING / INSERTABLE LEGENDS : contact APEM.

Bezel: rectangular, square, round, 'illum' - illuminated, 'Non-illum' - non illuminated



www.ermec.com

A02 series

Metal bezel pushbutton switches and indicators

Panel cut-out Ø 22 (.866)

A pushbutton assembly requires :

screen + lamp (if illuminated) + operator + one or two switch blocks.

An indicator assembly requires :

screen + lamp + operator

To order these elements, select desired model numbers from tables below.

Example : IP65 illuminated metal bezel maintained pushbutton, switch block with 2 N.O. contacts, red screen and 12V red LED assembly = A0263B, A0244J1, A0211X and A02503UL.

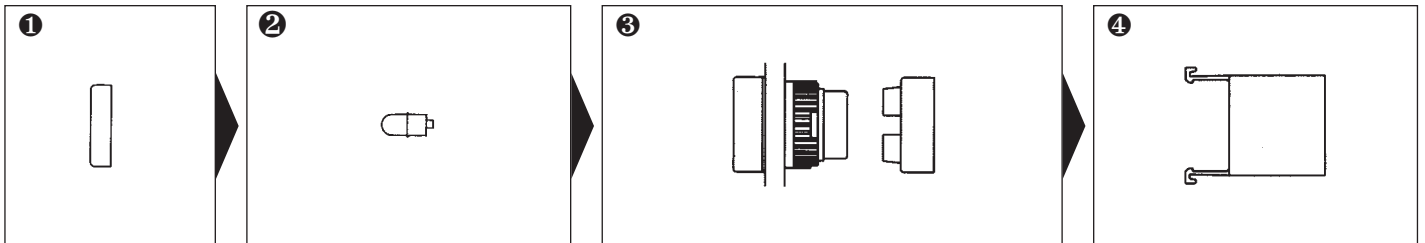
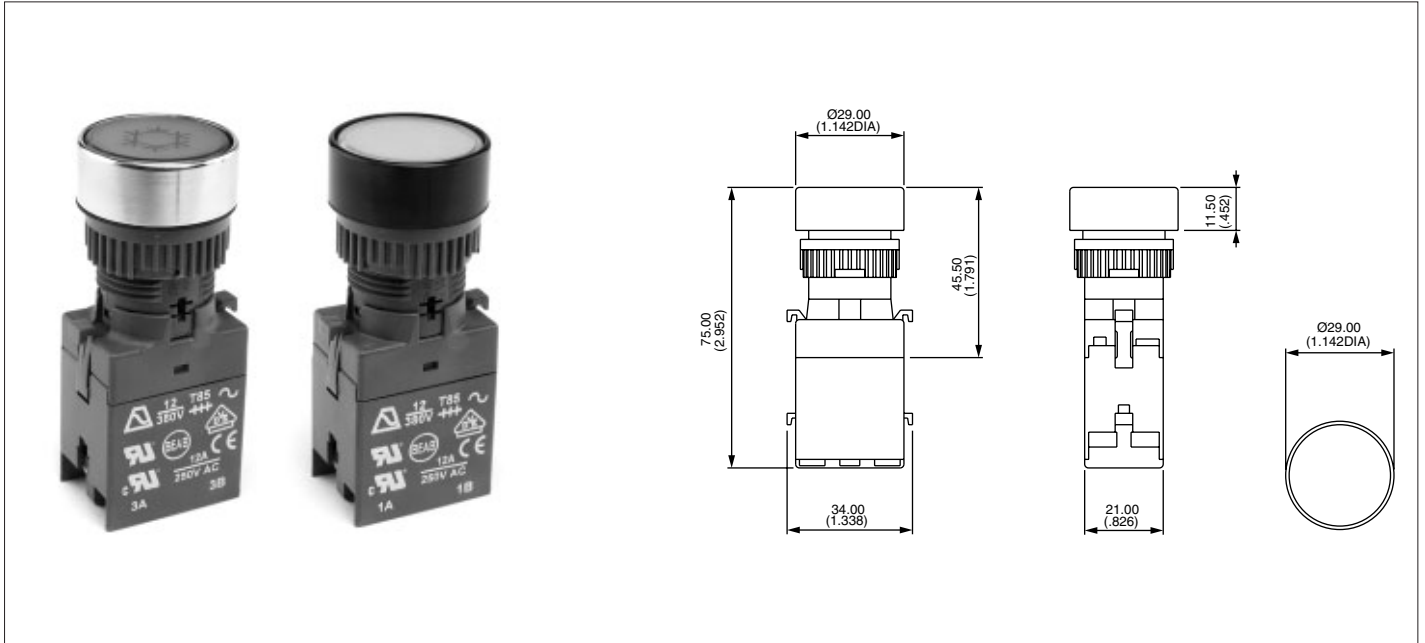
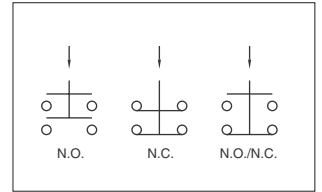

Screen

Bezel	Colour	Part No
○	black	A0263A
○	red	A0263B
○	amber	A0263C
○	yellow	A0263D
○	green	A0263E
○	blue	A0263F
○	clear	A0263G
○	white	A0263J

Lamp

Lamp	Voltage	Part No
Filament	6.3V	A0141A
Filament	14V	A0141B
Filament	28V	A0141C
Filament	36V	A0141D
Filament	48V	A0141E
Filament	60V	A0141F
Neon	110V	A0143G
Neon	220V	A0143H
LED	model numbers: see A01 pages G6-G7.	
LED assy	○ 6V	A0244H*
LED assy	○ 12V	A0244J*
LED assy	○ 24V	A0244K*
Replace *	with colour code	1: red
for LED assemblies:		2: green
		3: amber

White or blue LED assembly : contact APEM.

Operator

Bezel	Description	Lamp type	Part No
○	illum, momentary	Lamp/LED	A0210Y
○	illum, maintained	Lamp/LED	A0210X
○	illum, momentary	LED assy	A0211Y
○	illum, maintained	LED assy	A0211X
○	Non-illum, momentary		A0212Y
○	Non-illum, maintained		A0212X
○	illum, indicator	Lamp/LED	A0277
○	illum, indicator	LED assy	A0278

Std bezel material : nickel plated brass.
For optional black finish, add "G" to the end of operator model number.

UNSEALED SWITCHES (IP40) :
add "01" to end of operator model number.

Switch block

Contacts	Part No
1 N.O.	A02501UL
1 N.C.	A02502UL
2 N.O.	A02503UL
2 N.C.	A02504UL
1 N.O./1 N.C.	A02505UL

Second switch block

Contacts	Part No
1 N.O.	A02506UL
1 N.C.	A02507UL
2 N.O.	A02508UL
2 N.C.	A02509UL
1 N.O./1 N.C.	A02510UL

To achieve 3 or 4 pole switching, add second switch block, from above table.

SCREEN ENGRAVING / INSERTABLE LEGENDS : contact APEM.

Bezel: □ rectangular, □ square, ○ round, 'illum' - illuminated, 'Non-illum' - non illuminated

A02 series

ermec@ermec.com

Flush mounting pushbutton switches and indicators

Panel cut-out Ø 30 (1.181)

A pushbutton assembly requires :

screen + lamp (if illuminated) + operator + one or two switch blocks.

An indicator assembly requires :

screen + lamp + operator

To order these elements, select desired model numbers from tables below.

Example : IP65 illum. flush mounting maintained pushbutton, switch block with 2 N.O. contacts, red screen and 12V red LED assembly = A0263B, A0244J1, A0213X and A02503UL.

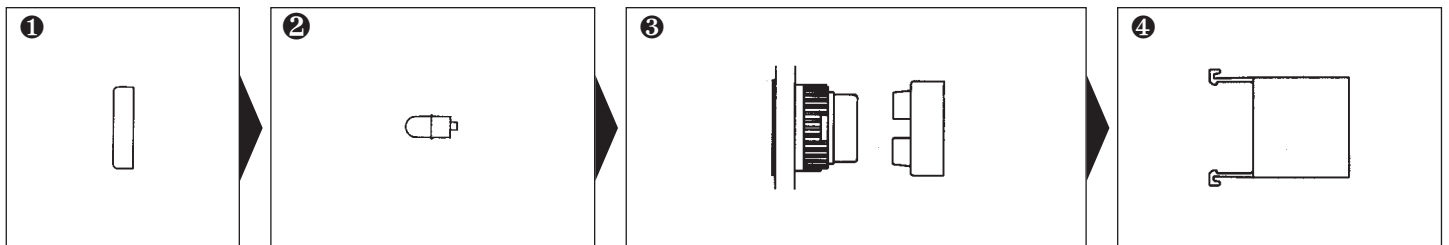
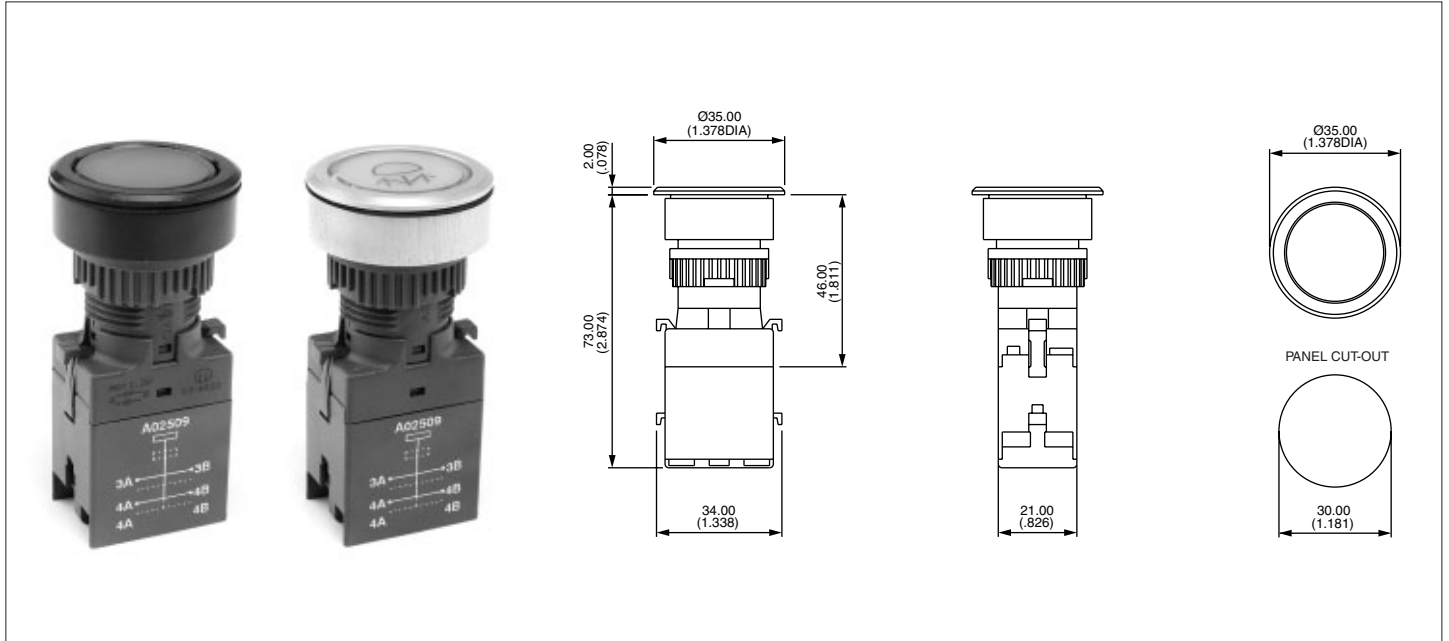
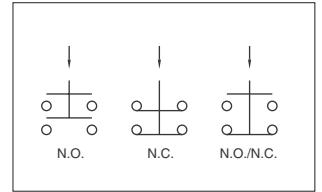

Screen

Bezel	Colour	Part No
○	black	A0263A
○	red	A0263B
○	amber	A0263C
○	yellow	A0263D
○	green	A0263E
○	blue	A0263F
○	clear	A0263G
○	white	A0263J

Lamp

Lamp	Voltage	Part No
Filament	6.3V	A0141A
Filament	14V	A0141B
Filament	28V	A0141C
Filament	36V	A0141D
Filament	48V	A0141E
Filament	60V	A0141F
Neon	110V	A0143G
Neon	220V	A0143H
LED	model numbers: see A01 pages G6-G7.	
LED assy ○	6V	A0244H*
LED assy ○	12V	A0244J*
LED assy ○	24V	A0244K*
Replace *	with colour code	1: red
for LED assemblies:		2: green
		3: amber

White or blue LED assembly :
contact APEM.

Operator

Bezel	Description	Lamp type	Part No
○	illum, momentary	Lamp/LED	A0214Y
○	illum, maintained	Lamp/LED	A0214X
○	illum, momentary	LED assy	A0213Y
○	illum, maintained	LED assy	A0213X
○	Non-illum, momentary		A0215Y
○	Non-illum, maintained		A0215X
○	illum, indicator	Lamp/LED	A02791
○	illum, indicator	LED assy	A02792

Std bezel material : silver anodised aluminium.
For optional black anodised aluminium, add "G"
to end of operator model number.

UNSEALED SWITCHES (IP40) :
add "01" to end of operator model number.

Switch block

Contacts	Part No
1 N.O.	A02501UL
1 N.C.	A02502UL
2 N.O.	A02503UL
2 N.C.	A02504UL
1 N.O./1 N.C.	A02505UL

Second switch block

Contacts	Part No
1 N.O.	A02506UL
1 N.C.	A02507UL
2 N.O.	A02508UL
2 N.C.	A02509UL
1 N.O./1 N.C.	A02510UL

To achieve 3 or 4 pole switching,
add second switch block, from
above table.

SCREEN ENGRAVING / INSERTABLE LEGENDS : contact APEM.

Bezel: □ rectangular, ◻ square, ○ round, 'illum' - illuminated, 'Non-illum' - non illuminated



www.ermec.com

A02 series

Indicators

Panel cut-out Ø 22 (.866) or 29,5 x 21,5 (1.160x.846)

An indicator assembly requires :

Screen + lamp, LED or LED assembly + operator.

To order these elements, select desired model numbers from tables below.

Example : IP65 rectangular indicator with red screen and 12V red LED assembly = A0261B, A0242J1 and A0272.

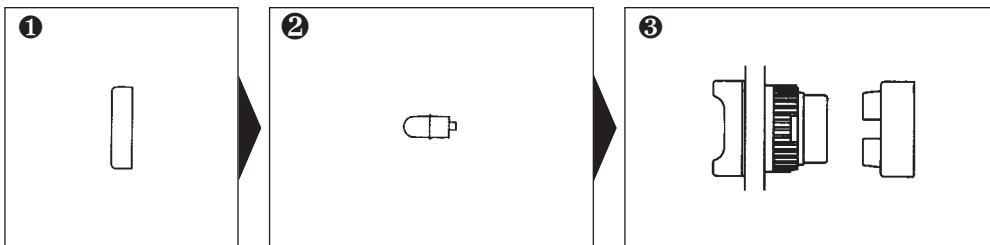
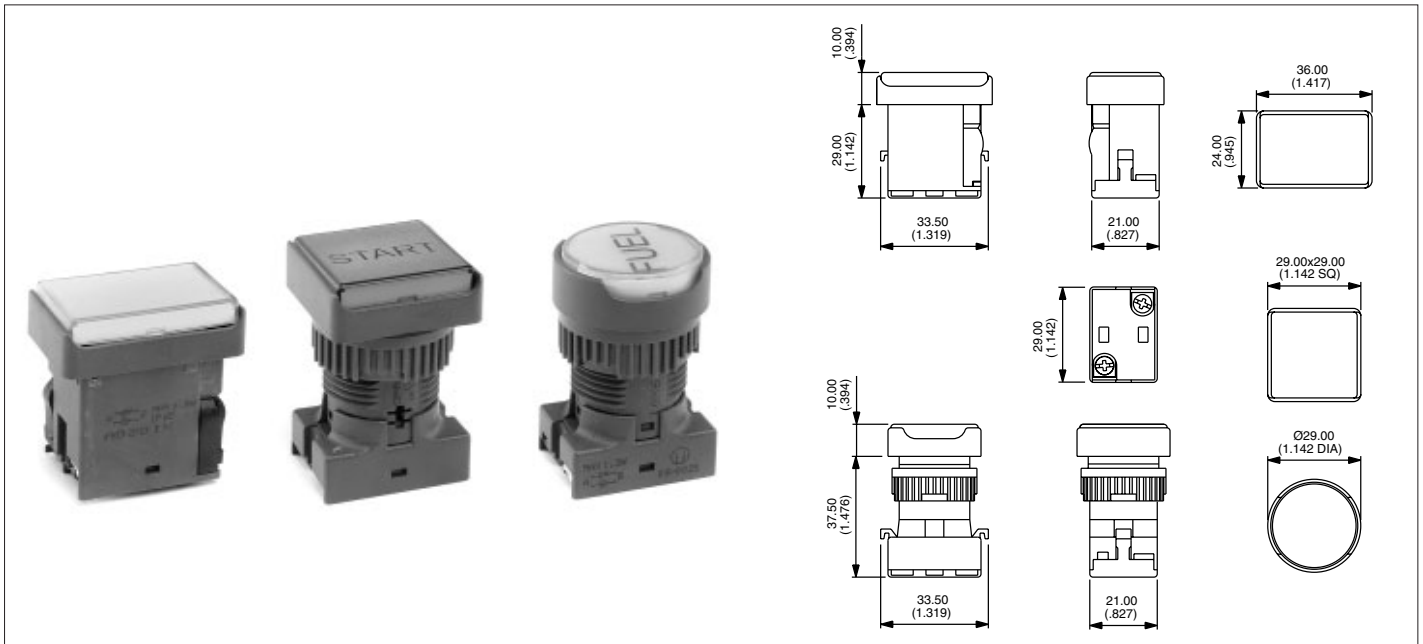

Screen

Bezel	Colour	Part No
□	black	A0261A
□	red	A0261B
□	amber	A0261C
□	yellow	A0261D
□	green	A0261E
□	blue	A0261F
□	clear	A0261G
□	white	A0261J
□	black	A0262A
□	red	A0262B
□	amber	A0262C
□	yellow	A0262D
□	green	A0262E
□	blue	A0262F
□	clear	A0262G
□	white	A0262J
□	black	A0263A
○	red	A0263B
○	amber	A0263C
○	yellow	A0263D
○	green	A0263E
○	blue	A0263F
○	clear	A0263G
○	white	A0263J

Lamp

Lamp	Voltage	Part No
Filament	6.3V	A0141A
Filament	14V	A0141B
Filament	28V	A0141C
Filament	36V	A0141D
Filament	48V	A0141E
Filament	60V	A0141F
Neon	110V	A0143G
Neon	220V	A0143H
LED	model numbers: see A01 pages G6-G7.	
LED assy	□ 6V	A0242H*
LED assy	□ 12V	A0242J*
LED assy	□ 24V	A0242K*
LED assy	□ 6V	A0243H*
LED assy	□ 12V	A0243J*
LED assy	□ 24V	A0243K*
LED assy	○ 6V	A0244H*
LED assy	○ 12V	A0244J*
LED assy	○ 24V	A0244K*
Replace * with colour code		
for LED assemblies:		
	1:	red
	2:	green
	3:	amber

Operator

Bezel	Description	Lamp type	Part No
□	Indicator	Lamp/LED	A0271
□	Indicator	LED assy	A0272
□	Indicator	Lamp/LED	A0273
□	Indicator	LED assy	A0274
○	Indicator	Lamp/LED	A0275
○	Indicator	LED assy	A0276

UNSEALED INDICATORS (IP40) :

add "01" to end of operator model number.

White or blue LED assembly :

contact APEM.

SCREEN ENGRAVING / INSERTABLE LEGENDS : contact APEM.

Bezel: □ rectangular, □ square, ○ round,



www.ermec.com

A02 series

ermec@ermec.com

Rotary switches

Panel cut-out Ø 22 (.866)

A rotary lever assembly requires :
operator + one or two switch blocks.

To order these elements, select desired model numbers from tables below.

Example : IP65 square 2 position maintained rotary switch with long lever, clockwise rotation, switch block with 2 N.O. contacts = A029107 and A02503UL.

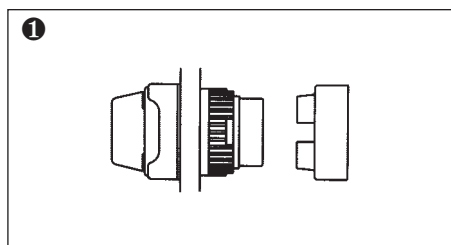
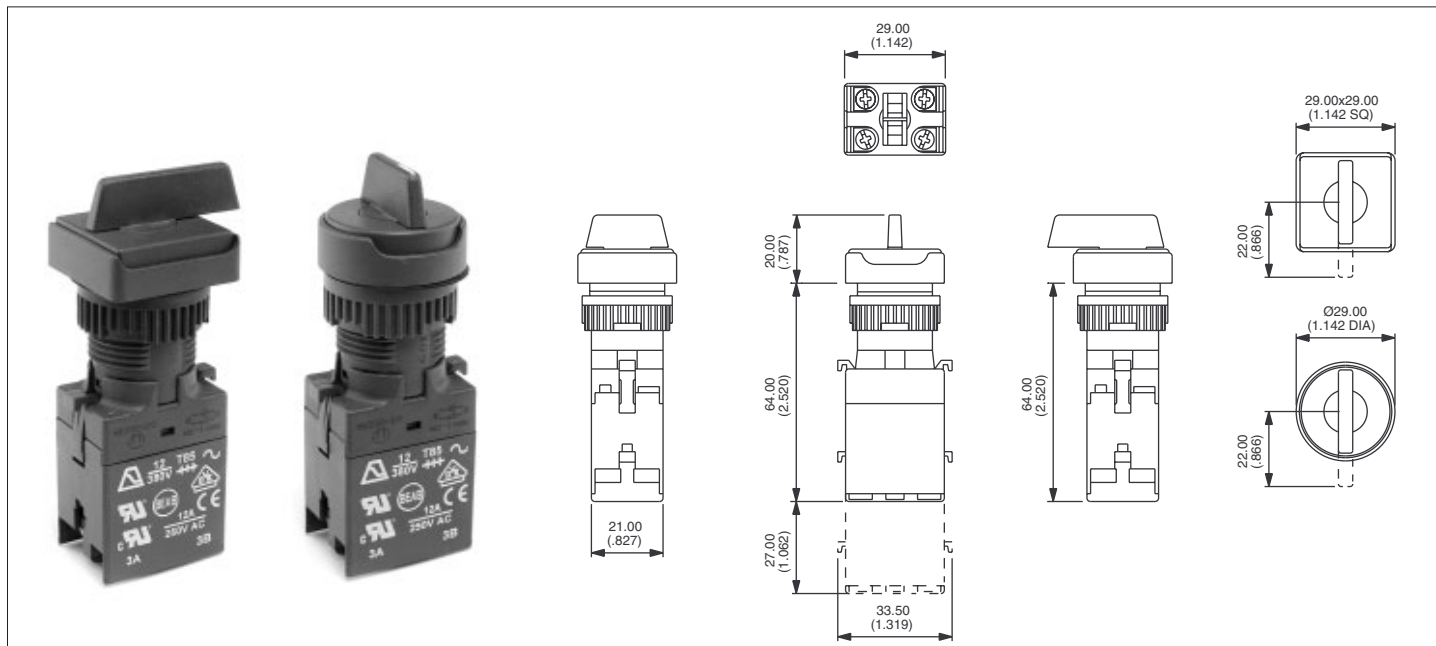
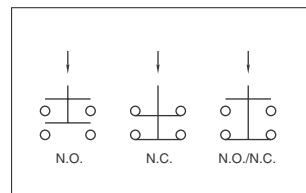

Operator

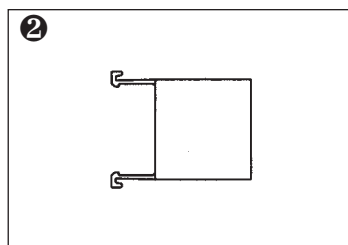

Switch block

Lever positions

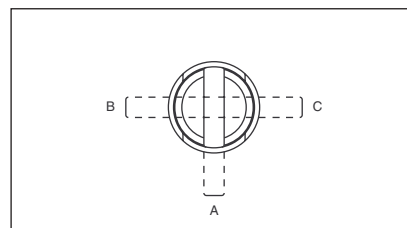

• Lever Rotation - 2 position switches

The model numbers shown are for switches with clockwise lever rotation.

For anticlockwise rotation, replace :

07 with **01**
08 with **02**

at the end of the model number.

Bezel	Description	Short lever	Long lever
<input type="checkbox"/>	2 pos. maintained	A029207	A029107•
<input type="checkbox"/>	2 pos. momentary	A029208	A029108•
<input type="checkbox"/>	3 pos. maintained	A029203	A029103
<input type="checkbox"/>	3 pos. momentary	A029204	A029104
<input type="checkbox"/>	3 pos. mainL, momR	A029205	A029105
<input type="checkbox"/>	3 pos. momL, mainR	A029206	A029106
<input type="checkbox"/>	2 pos. maintained	A029407	A029307•
<input type="checkbox"/>	2 pos. momentary	A029408	A029308•
<input type="checkbox"/>	3 pos. maintained	A029403	A029303
<input type="checkbox"/>	3 pos. momentary	A029404	A029304
<input type="checkbox"/>	3 pos. mainL, momR	A029405	A029305
<input type="checkbox"/>	3 pos. momL, mainR	A029406	A029306

Contacts	Part No
1 N.O.	A02501UL
1 N.C.	A02502UL
2 N.O.	A02503UL
2 N.C.	A02504UL
1 N.O./1 N.C.	A02505UL

Second switch block

Contacts	Part No
1 N.O.	A02506UL
1 N.C.	A02507UL
2 N.O.	A02508UL
2 N.C.	A02509UL
1 N.O./1 N.C.	A02510UL

To achieve 3 or 4 pole switching, add second switch block, from above table.

OPTION

To specify flush mounting (30 mm Ø) option, add "FM" to the end of the part number (for round operators only).

Example : A029407FM.

Optional engraving on lever end



To order, add "WL" to the end of the part No.
Example : A029407WL.

Bezel: square, round,



www.ermec.com

A02 series

Keylock switches

Panel cut-out Ø 22 or 29,5 x 21,5

A keyswitch assembly requires :

operator + one or two switch blocks.

To order these elements, select desired model numbers from tables below.

Example : IP65 square 2 position keyswitch, clockwise rotation, switch block with 2 N.O. contacts = A028220 and A02503UL.

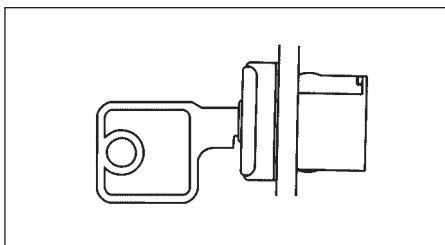
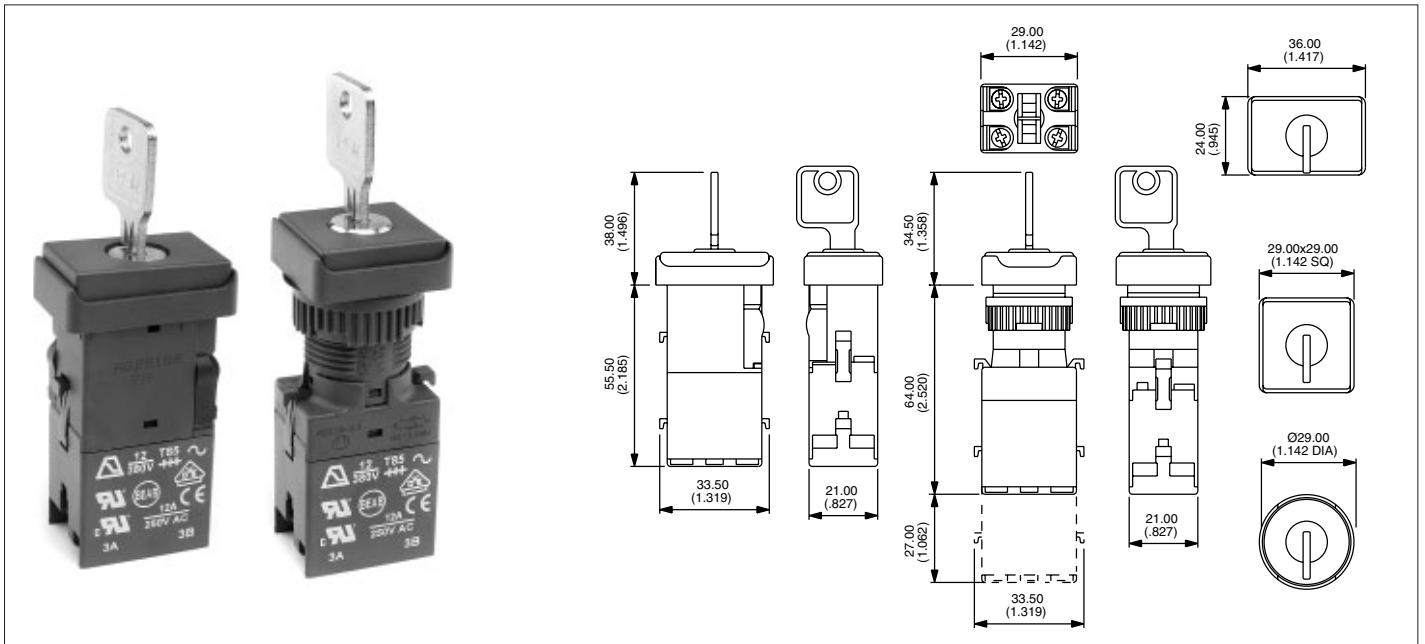
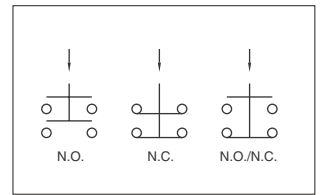

Operator

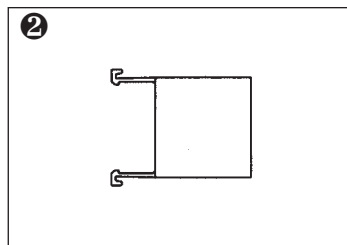

Switch block

Key positions

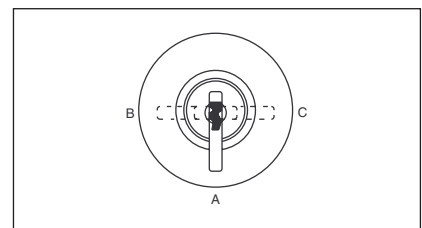

Bezel	Description	Part No	Key removable in positions
□	2 pos. maintained	A028120•	A-B
□	2 pos. momentary	A028119•	A
□	3 pos. maintained	A028105	A-B-C
□	3 pos. momentary	A028106	A
□	3 pos. mainL, momR	A028107	A-B
□	3 pos. momL, mainR	A028108	A-C
□	2 pos. maintained	A028220•	A-B
□	2 pos. momentary	A028219•	A
□	3 pos. maintained	A028205	A-B-C
□	3 pos. momentary	A028206	A
□	3 pos. mainL, momR	A028207	A-B
□	3 pos. momL, mainR	A028208	A-C
○	2 pos. maintained	A028320•	A-B
○	2 pos. momentary	A028319•	A
○	3 pos. maintained	A028305	A-B-C
○	3 pos. momentary	A028306	A
○	3 pos. mainL, momR	A028307	A-B
○	3 pos. momL, mainR	A028308	A-C

Contacts	Part No
1 N.O.	A02501UL
1 N.C.	A02502UL
2 N.O.	A02503UL
2 N.C.	A02504UL
1 N.O./1 N.C.	A02505UL

Second switch block

Contacts	Part No
1 N.O.	A02506UL
1 N.C.	A02507UL
2 N.O.	A02508UL
2 N.C.	A02509UL
1 N.O./1 N.C.	A02510UL

To achieve 3 or 4 pole switching, add second switch block, from above table

• Key Rotation - 2 position switches

The model numbers shown are for switches with clockwise key rotation. For anticlockwise rotation, replace:

20 with **01**
19 with **02**

at the end of the model number

- 2 standard keys are supplied.
- 20 key barrel types available from stock.

Non-removable key positions : contact APEM.

OPTION

To specify **flush mounting (30 mm Ø) option**, add "FM" to the end of the part number (for round operators only). Example : A028320FM.

Bezel: □ rectangular, □ square, ○ round,



www.ermec.com

A02 series

ermec@ermec.com

Emergency stop switches

Panel cut-out Ø 22 (.866)

- Prominent 40 mm (1.575) dia. red mushroom actuator
- Highly reliable positive break switch
- Push to shut off switch, twist to reset to ON
- Approved to UL 1054 / EN 60947-5-5

An emergency stop switch assembly requires : operator + switch block.

To order, specify with single pole or double pole positive break switch block.

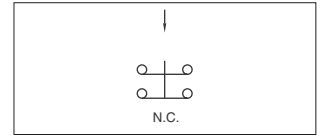

General specifications

- Mechanical life : 6.050 cycles (6 cycles per minute)
- Operating force : 20 N
- Operating temperature : -20°C to +85°C
- Degree of environ. protection (IEC529) : IP65 front of panel, IP40 back of panel
- Switch terminals : M3 screws - wire 2x0.75mm² max.

Electrical specifications

- Current/voltage rating : 2,5A 380VAC AC-15
- Contact gap : > 3 mm (.118)
- Dielectric strength : 2.500V
- Electrical life : 6.050 cycles

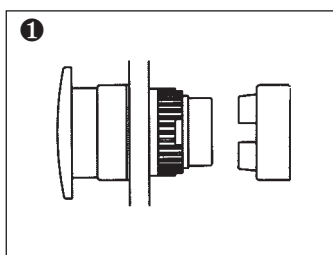
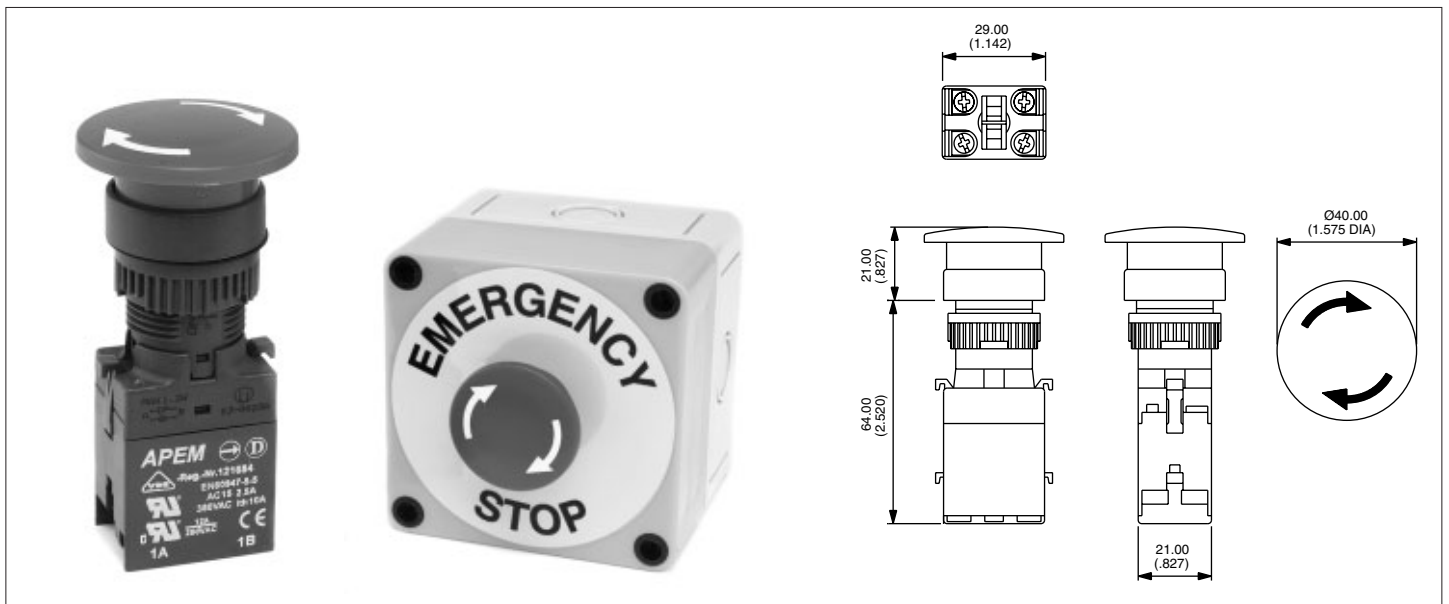

Operator

Bezel	Description	Part No.
	Emergency stop	A02ES

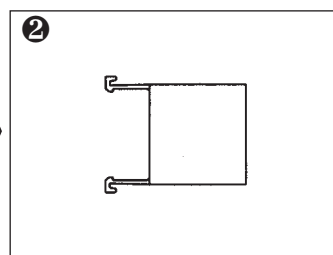

Switch block

No. of poles	Part No.
Double pole	A02511
Single pole	A02512

Accessory



90 mm Ø Self Adhesive Label

Description	Part No.
Yellow label with text	A02YL1
Yellow label	A02YL2

EMERGENCY STOP SWITCH ENCLOSURE

To order the Emergency Stop Switch in the Plastic Enclosure (94 x 94 x 81 mm) with a 2 pole Positive Break Switch Block and Emergency Stop label, use Part number : A02PE2L.



www.ermec.com

A02 series

Mushroom head pushbutton switches

Panel cut-out Ø 22 (.866)

- Prominent 40 mm (1.575) dia. mushroom actuator or optional 26 mm (1.024) actuator
- Momentary and maintained functions
Momentary function versions are unmarked
Maintained function versions are twist to release (arrows indicate direction of twist)
- Various coloured mushroom actuators are available

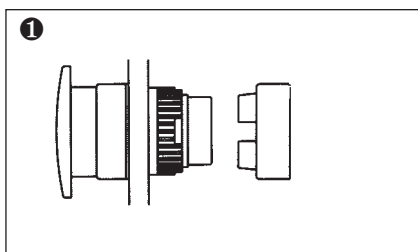
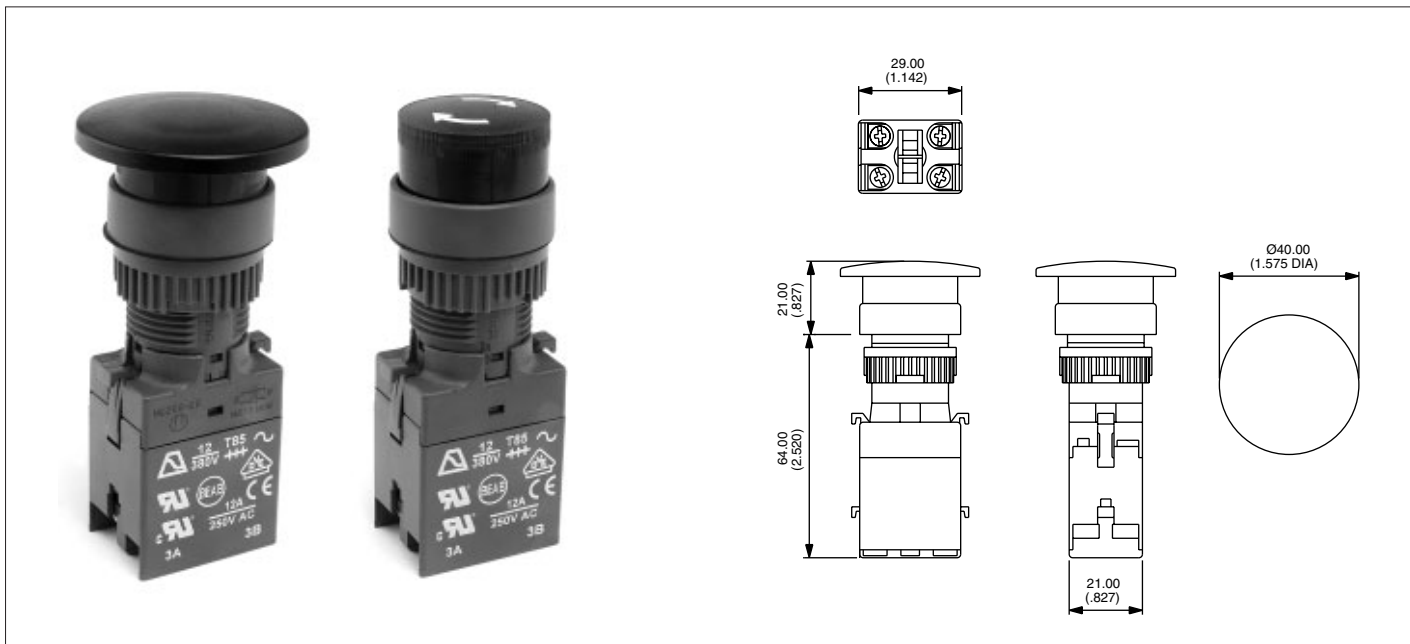
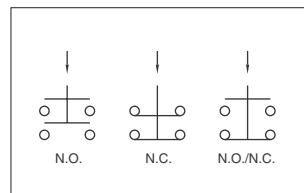

Operator

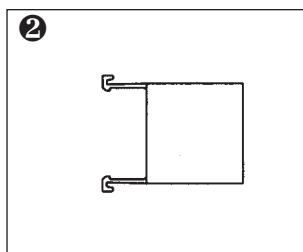

Switch block

Bezel	Description	Part No
○	Black momentary	A02MMA
○	Red momentary	A02MMB
○	Yellow momentary	A02MMD
○	Green momentary	A02MME
○	Blue momentary	A02MMF
○	Black maintained	A02MXA
○	Red maintained	A02MXB
○	Yellow maintained	A02MXD
○	Green maintained	A02MXE
○	Blue maintained	A02MXF

Contacts	Part No
1 N.O.	A02501UL
1 N.C.	A02502UL
2 N.O.	A02503UL
2 N.C.	A02504UL
1 N.O./1 N.C.	A02505UL

Second switch block

Contacts	Part No
1 N.O.	A02506UL
1 N.C.	A02507UL
2 N.O.	A02508UL
2 N.C.	A02509UL
1 N.O./1 N.C.	A02510UL

OPTION

For optional reduced (Ø 26 mm) mushroom head operators : contact APEM.

To achieve 3 or 4 pole switching, add second switch block, from above table

Bezel: ○ round



www.ermec.com

Modular construction / panel mounting

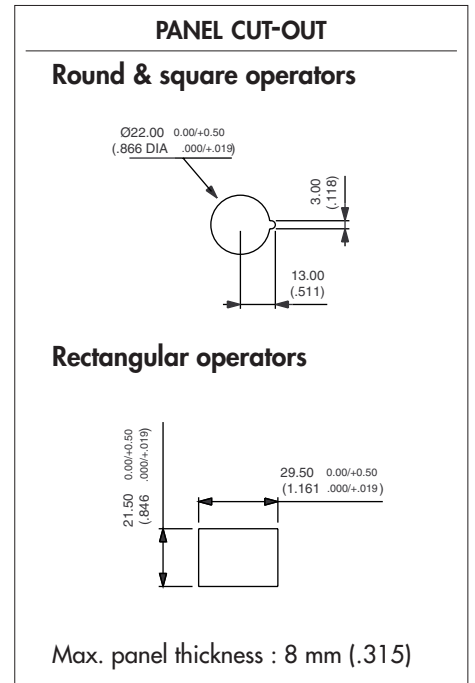
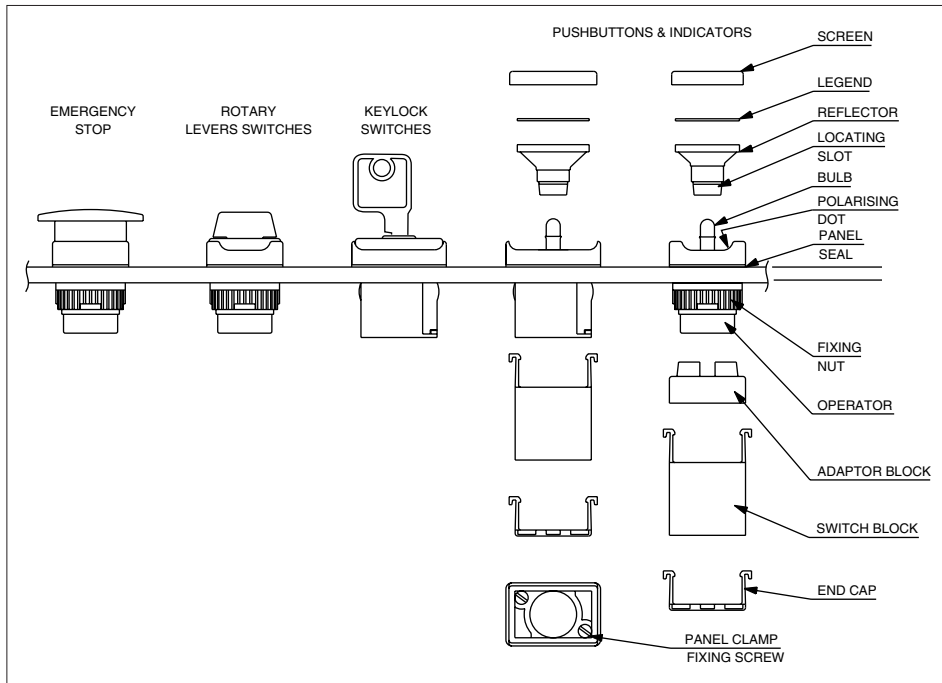

PANEL MOUNTING ASSEMBLY

- Drill/punch hole in panel as shaped above.
- Assemble front operator through hole and :
 - a/ *Round & square types* : tighten nut to a maximum torque of 0,8Nm using tool No 30-0001. Snap on adaptor block
 - b/ *Rectangular types* : tighten two panel fixing screws in front to a maximum torque of 6cNm.
- Wire chosen switch block as required and snap onto front operator.
- Snap end cap onto switch block.
- Fit bulb if required using tool No 30-0002.
- Snap screen onto reflector assembly with legend in between if required and snap into front operator **TAKING CARE TO LINE UP THE LOCATING SLOT WITH THE POLARISING DOT**, and not to damage the seal.

TO REMOVE BULB

Remove reflector/screen assembly. Use the bulb extractor 30-0002 to remove the bulb.

TO REMOVE SWITCH BLOCK

Lever out latches using small screwdriver taking care not to overbend, and pull off the block from the front operator.

A02 Accessories

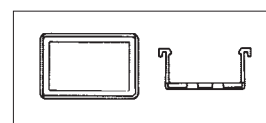

Part No : 14-0005

End cap terminal guard offering unique terminal protection.

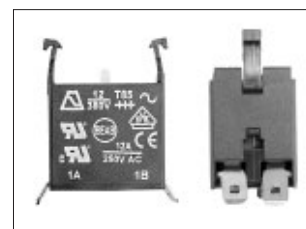

6.35 mm push on tab terminals.

Specify "SP" to the end of the switchblock and operator P/N. Example : A02503SP.



A03 series

Illuminated or non-illuminated pushbutton switches and indicators

Panel cut-out Ø 22 (.866) or 30 (1.181) - Plastic or metal flush mounting bezel

A pushbutton assembly requires :

screen + lamp (if illuminated) + operator + switch block.

To order these elements, select desired model numbers from tables below.

Example : IP65 flush mounting round pushbutton, maintained function, red screen, 12V red LED and single pole switch block = A0314X, A0263B, A0142M1 and A0151BUL.

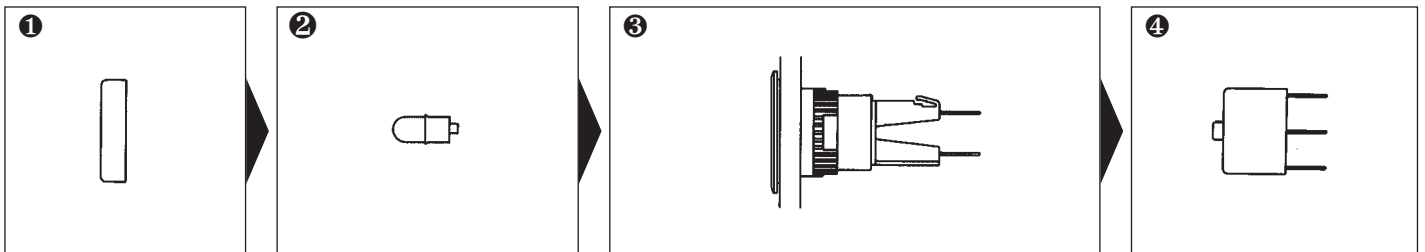
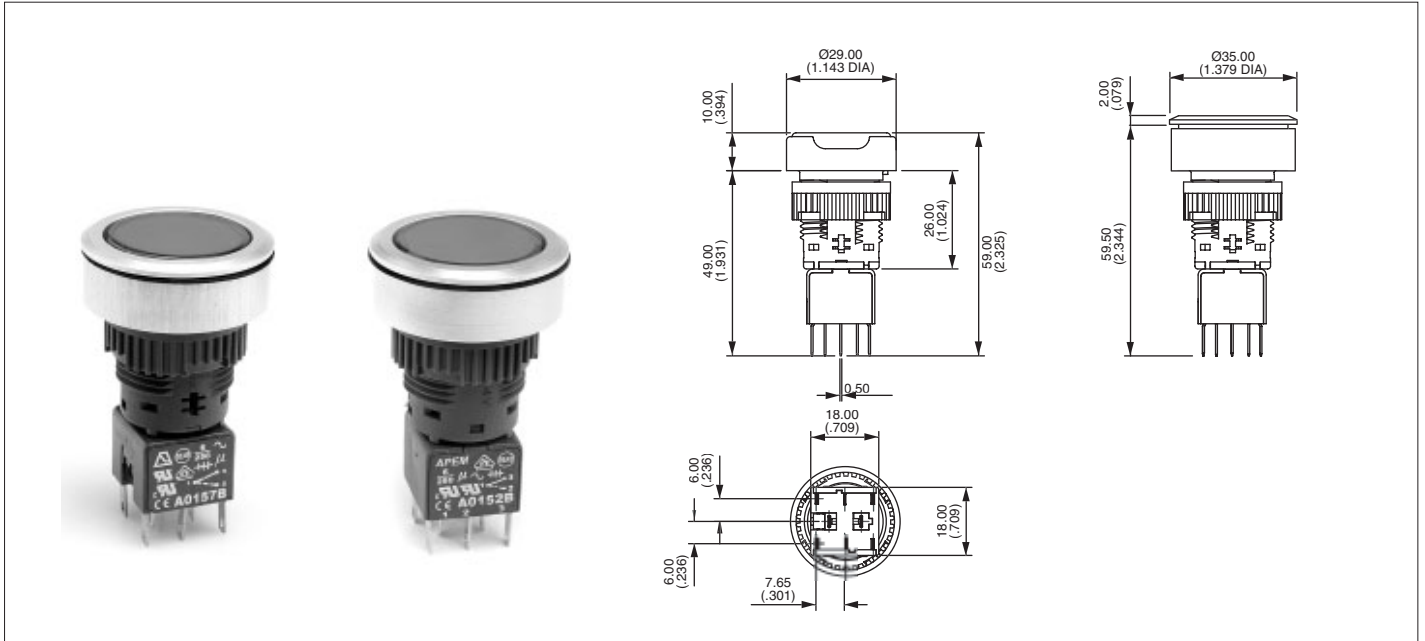
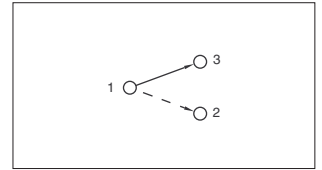

Screen

Bezel	Colour	Part No
○	black	A0263A
○	red	A0263B
○	amber	A0263C
○	yellow	A0263D
○	green	A0263E
○	blue	A0263F
○	clear	A0263G
○	white	A0263J

Lamp

Lamp	Voltage	Part No
Filament	6.3V	A0141A
Filament	14V	A0141B
Filament	28V	A0141C
Filament	36V	A0141D
Filament	48V	A0141E
Filament	60V	A0141F
Neon	110V	A0143G
Neon	220V	A0143H
LED	6V red	A0142L1
LED	6V green	A0142L2
LED	6V amber	A0142L3
LED	12V red	A0142M1
LED	12V green	A0142M2
LED	12V amber	A0142M3
LED	12V blue	A0142M4
LED	12V white	A0142M5
LED	24V red	A0142N1
LED	24V green	A0142N2
LED	24V amber	A0142N3
LED	24V blue	A0142N4
LED	24V white	A0142N5
LED	48V red	A0142P1
LED	48V green	A0142P2
LED	48V amber	A0142P3

Operator

Bezel	Description	Lamp type	Part No
○	Plastic illum, momentary	Lamp/LED bulb	A0307Y
○	Plastic illum, maintained	Lamp/LED bulb	A0307X
○	Plastic non-illum, momentary		A0309Y
○	Plastic non-illum, maintained		A0309X
○	Metal illum, momentary	Lamp/LED bulb	A0310Y
○	Metal illum, maintained	Lamp/LED bulb	A0310X
○	Metal non-illum, momentary		A0312Y
○	Metal non-illum, maintained		A0312X
○	F/mount illum, momentary	Lamp/LED bulb	A0314Y
○	F/mount illum, maintained	Lamp/LED bulb	A0314X
○	F/mount non-illum, momentary		A0315Y
○	F/mount non-illum, maintained		A0315X
○	Plastic indicator		A0375
○	Metal indicator		A0377
○	F/mount indicator		A03791

Switch block

No of poles	Part No
Single pole	A0151BUL
Double pole	A0152BUL
Three pole	A0155BUL
Four pole	A0153BUL

UNSEALED SWITCHES (IP40) :

add "01" to end of operator model number.

SCREEN ENGRAVING / INSERTABLE LEGENDS : contact APEM.

Bezel: ○ round. 'illum' - illuminated, 'Non-illum' - non illuminated



www.ermec.com