



## 2.54 mm Single Row Connector (SRC) MaxiBridge™

ERMEC, S.L. BARCELONA  
C/ Francesc Teixidó, 22  
E-08918 Badalona  
(Spain)



Tel.: (+34) 902 450 160  
Fax: (+34) 902 433 088  
[info@ermec.com](mailto:info@ermec.com)  
[www.ermec.com](http://www.ermec.com)

ERMEC, S.L. MADRID  
C/ Sagasta, 8, 1ª planta  
E-28004 Madrid  
(Spain)

PORTUGAL  
[portugal@ermec.com](mailto:portugal@ermec.com)  
BILBAO  
[bilbao@ermec.com](mailto:bilbao@ermec.com)

[www.erni.com](http://www.erni.com)



<b>ERMEC, S.L. BARCELONA</b> C/ Francesc Teixidó, 22 E-08918 Badalona (Spain)	 Distribución de componentes eléctricos y electrónicos	<b>Tel.: (+34) 902 450 160</b> <b>Fax: (+34) 902 433 088</b> <a href="mailto:info@ermec.com">info@ermec.com</a> <a href="http://www.ermec.com">www.ermec.com</a>	<b>ERMEC, S.L. MADRID</b> C/ Sagasta, 8, 1ª planta E-28004 Madrid (Spain)	<b>PORTUGAL</b> <a href="mailto:portugal@ermec.com">portugal@ermec.com</a> <b>BILBAO</b> <a href="mailto:bilbao@ermec.com">bilbao@ermec.com</a>
--	---	---	--	--

[www.erni.com](http://www.erni.com)

# 2.54 mm Single Row Connectors (SRC) MaxiBridge™

## Table of Contents



General .....	.2
Electrical and Mechanical Characteristics .....	.3
Right Angle Male Connectors .....	.6
Vertical Male Connectors .....	.8
Vertical Female Connectors .....	.10
Crimp Contacts and Tools .....	.12
Cable Assemblies .....	.13
Part Number Index .....	.15



ERMEC, S.L. BARCELONA  
C/ Francesc Teixidó, 22  
E-08918 Badalona  
(Spain)

Tel.: (+34) 902 450 160  
Fax: (+34) 902 433 088  
[info@ermec.com](mailto:info@ermec.com)  
[www.ermec.com](http://www.ermec.com)

ERMEC, S.L. MADRID  
C/ Sagasta, 8, 1ª planta  
E-28004 Madrid  
(Spain)

PORTUGAL  
[portugal@ermec.com](mailto:portugal@ermec.com)  
BILBAO  
[bilbao@ermec.com](mailto:bilbao@ermec.com)

# 2.54 mm Single Row Connectors (SRC) MaxiBridge™

## General



The 2.54 mm single row cable connector system is ideally suitable for high reliable and space saving connections between PCBs and decentral units, e.g. lamps or info-panels, front plate elements like buttons, switches, fuses or LEDs, motors, fans etc. The cable system can be used in different applications, for example: automotive, telecom, industrial, medical or even consumer electronics.

Thanks to the availability of vertical and right angle male connectors and female connectors with 180° cable outlet the system can be used in a versatile manner. Emphasis is put on flexibility of the usable cable sizes. Thus the required current carrying capacity can be adjusted over a wide range.

The male connector provides SMT-terminals and the female connector has contact cavities according to the crimp contacts. The plastic material used is suitable for lead-free reflow soldering.

Tape-and-Reel packaging and pick and place pad for fully automatic assembly is a standard. The crimp contacts are secured twice and reach highest retention forces. There are 4 mechanical and different coloured coding versions with high blocking forces against mismatching. Cable and male connector have a locking system which prevents the contact from loosening due to vibration. The cable connector can be removed without an additional tool.

### Technical Features

- Number of pins: 2, 3, 5, 6 and 8
- Pitch: 2.54 mm
- Current carrying capacity per contact: up to 12 A\*  
(8 Pos connector up to 96 A\* per connector)
- Termination: Male connector SMT  
Female connector crimp
- Single stranded wires: AWG 16, 18, 20, 22, 24, 26
- Vertical and right angle male connector  
Female connector 180° cable outlet
- Robust positive locking feature
- 4 coding versions: black, red, green, blue

\* For specific data, please see the corresponding derating curve.



**ERMEC, S.L. BARCELONA**  
C/ Francesc Teixidó, 22  
E-08918 Badalona  
(Spain)

**Tel.: (+34) 902 450 160**  
**Fax: (+34) 902 433 088**  
[info@ermec.com](mailto:info@ermec.com)  
[www.ermec.com](http://www.ermec.com)

**ERMEC, S.L. MADRID**  
C/ Sagasta, 8, 1ª planta  
E-28004 Madrid  
(Spain)

**PORTUGAL**  
[portugal@ermec.com](mailto:portugal@ermec.com)  
**BILBAO**  
[bilbao@ermec.com](mailto:bilbao@ermec.com)

## 2.54 mm Single Row Connectors (SRC) MaxiBridge™



### Electrical and Mechanical Characteristics

	Standard	Male Connectors Type A and P	Female Connectors Type A with crimp contact
Number of Pins		2, 3, 5, 6 and 8	2, 3, 5, 6 and 8
<b>Technical data</b>			
Climate category	DIN EN 60068-1 test b	55/125/56	55/125/56
Beraring and operating temperature area		-55/150 °C	-55/150 °C
Current rating per contact		Depending on used cable and limit temperature; see derating curve.	Depending on used cable and limit temperature; see derating curve.
Air- and creepage distance		contact - contact 1.2 mm	contact - contact 1.2 mm
Voltage rating	IEC60664	The permissible operating voltages depend on the customer application and on the applicable or specified safety requirements. Insulation coordination according to IEC 60664-1 has to be regarded for the complete electrical device. Therefore, the maximum creepage and clearance distances of the mated connectors are specified for consideration as a part of the whole current path. In practice, reductions in creepage or clearance distances may occur due to the conductive pattern of the printed board or the wiring used, and have to be taken into account separately. As a result the creepage and clearance distances for the application may be reduced compared to those of the connector.	
Dielectric strength	IEC 60512 test 4a	contact – contact 1000 V <sub>rms</sub>	contact – contact 1000 V <sub>rms</sub>
Contact resistance	IEC 60512 test 2a	< 20 mΩ	< 20 mΩ
Insulation resistance	IEC 60512 test 3a	> 10 <sup>4</sup> MΩ	> 10 <sup>4</sup> MΩ
Vibration, sine	IEC 60512 test 6d	10 - 2000 Hz 20 g	10 - 2000 Hz 20 g
Contact disturbance (while vibration test)	IEC 60512 test 2e	< 1 μs	< 1 μs
Shock, halfsine	IEC 60512 test 6c	50 g 11 ms	50 g 11 ms
Contact disturbance (while shock test)	IEC 60512 test 2e	< 1μs	< 1μs
Mechanical operation (mating cycles)	IEC 60512 test 9a	> 250 mating cycles	> 250 mating cycles
Insertion and withdrawal force	IEC 60512 test 13b	5 pin version ≤ 5 N	5 pin version ≤ 5 N
Gauge retention force	IEC 60512 test 16e	> 0.15 N	> 0.15 N



**ERMEC, S.L. BARCELONA**  
C/ Francesc Teixidó, 22  
E-08918 Badalona  
(Spain)

**Tel.: (+34) 902 450 160**  
**Fax: (+34) 902 433 088**  
[info@ermec.com](mailto:info@ermec.com)  
[www.ermec.com](http://www.ermec.com)

**ERMEC, S.L. MADRID**  
C/ Sagasta, 8, 1ª planta  
E-28004 Madrid  
(Spain)

**PORTUGAL**  
[portugal@ermec.com](mailto:portugal@ermec.com)  
**BILBAO**  
[bilbao@ermec.com](mailto:bilbao@ermec.com)

## 2.54 mm Single Row Connectors (SRC) MaxiBridge™



### Electrical and Mechanical Characteristics

	Standard	Male Connectors Type A and P	Female Connectors Type P with crimp contact
Number of Pins		2, 3, 5, 6 and 8	2, 3, 5, 6 and 8
<b>Process-conditions</b>			
Soldering temperature max.	IEC 68-2-20		
Hand soldering temperature max.		3.5 s at 350 °C	
Dip soldering temperature max.		10 s at 260 °C	
Reflow soldering temperature max.	JEDEC J-STD-020C	20 - 40 s at 260 °C	
Coplanarity		< 0.1 mm	
<b>Housing Materials</b>			
Plastic material		LCP	PA46
CTI value	IEC 60112	175	250
UL flame rating		UL 94 V-0	UL 94 V-0
UL file		E83005	E47960
<b>Contact Materials</b>			
Base material		Cu alloy	Cu alloy
Mating area		min. 1.0 µm PdNi 0.1 µm Au over 2-3 µm Ni	min. 1.0 µm PdNi 0.1 µm Au over 2-3 µm Ni
Termination area		4-6 µm Sn matt over 2-3 µm Ni	0.5-2 µm Sn matt over 2-3 µm Ni
<b>Environment compatibility</b>			
Recycling		no flame-retardant additives, no toxic additives allows easy recycling	
<b>Product-approval</b>			
UL		in preparation	in preparation



ERMEC, S.L. BARCELONA  
C/ Francesc Teixidó, 22  
E-08918 Badalona  
(Spain)

Tel.: (+34) 902 450 160  
Fax: (+34) 902 433 088  
[info@ermec.com](mailto:info@ermec.com)  
[www.ermec.com](http://www.ermec.com)

ERMEC, S.L. MADRID  
C/ Sagasta, 8, 1ª planta  
E-28004 Madrid  
(Spain)

PORTUGAL  
[portugal@ermec.com](mailto:portugal@ermec.com)  
BILBAO  
[bilbao@ermec.com](mailto:bilbao@ermec.com)

## 2.54 mm Single Row Connectors (SRC) MaxiBridge™

### Electrical and Mechanical Characteristics



Standard	Standard Cable (PVC)
Number of Pins	2, 3, 5, 6 and 8
<b>Cable data</b>	
Cross-section	AWG 20 / 7 tinned wire
Conductor cross-section	0.56 mm <sup>2</sup>
Bending radius (one time)	10 mm
Bending radius (repeated)	20 mm
Outer diameter $\pm 3\%$	1.9 mm
Operating voltage	max. 300 V
Operating temperature	max. 105 °C
Insulator material	PVC
<b>Product-approval</b>	
UL	1007/1569 TR64



ERMEC, S.L. BARCELONA  
C/ Francesc Teixidó, 22  
E-08918 Badalona  
(Spain)

Tel.: (+34) 902 450 160  
Fax: (+34) 902 433 088  
[info@ermec.com](mailto:info@ermec.com)  
[www.ermec.com](http://www.ermec.com)

ERMEC, S.L. MADRID  
C/ Sagasta, 8, 1ª planta  
E-28004 Madrid  
(Spain)

PORTUGAL  
[portugal@ermec.com](mailto:portugal@ermec.com)  
BILBAO  
[bilbao@ermec.com](mailto:bilbao@ermec.com)

# 2.54 mm Single Row Connectors (SRC) MaxiBridge™

## Right Angle Male Connectors



### Dimensional Drawing 5 Pin Version

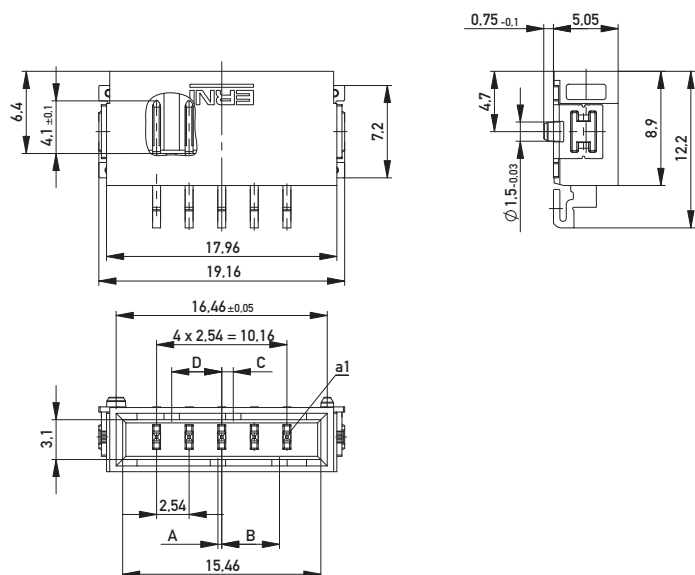

### PCB-LAYOUT Proposal for SMT

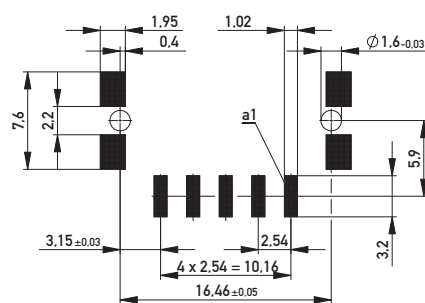

254826		red	3.9	0.9	4.5	0.3
254825		green	2.7	2.1	3.3	1.5
254824		blue	1.5	3.3	2.1	2.7
254823		black	0.3	4.5	0.9	3.9
Part-No.	Coding	Color	A	B	C	D

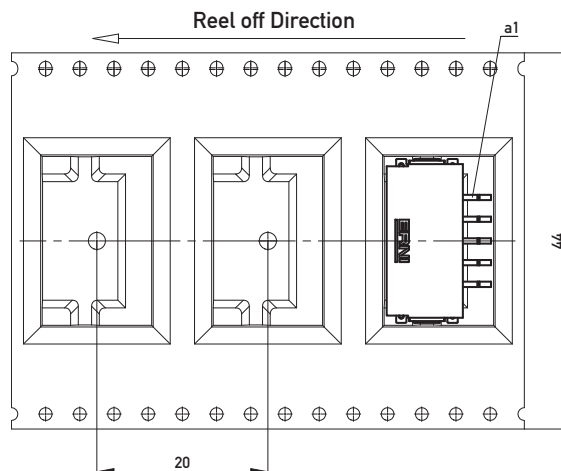
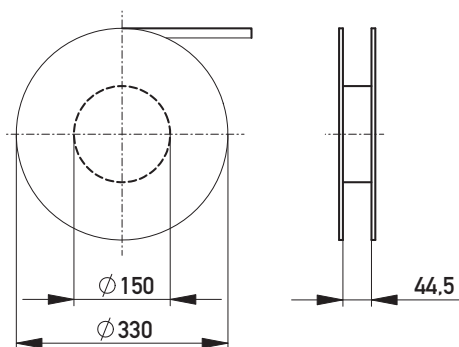

**ERMEC**  
 www.ermec.com  
 Distribución de componentes  
 eléctricos y electrónicos

Tel.: (+34) 902 450 160  
 Fax: (+34) 902 433 088  
[ermec@ermec.com](mailto:ermec@ermec.com)  
[www.ermec.com](http://www.ermec.com)



## 2.54 mm Single Row Connectors (SRC) MaxiBridge™

### Right Angle Male Connectors



#### Ordering Information

Configuration	Number of Pins	Termination	Coding	Packaging/Unit	Part Number
Right Angle Male	2	SMT	black	Tape and reel/440 pcs	<b>234832</b>
Right Angle Male	2	SMT	blue	Tape and reel/440 pcs	<b>234833</b>
Right Angle Male	2	SMT	green	Tape and reel/440 pcs	<b>234834</b>
Right Angle Male	2	SMT	red	Tape and reel/440 pcs	<b>234835</b>
Right Angle Male	3	SMT	black	Tape and reel/440 pcs	<b>284052</b>
Right Angle Male	3	SMT	blue	Tape and reel/440 pcs	<b>284053</b>
Right Angle Male	3	SMT	green	Tape and reel/440 pcs	<b>284054</b>
Right Angle Male	3	SMT	red	Tape and reel/440 pcs	<b>284055</b>
Right Angle Male	5	SMT	black	Tape and reel/440 pcs	<b>254823</b>
Right Angle Male	5	SMT	blue	Tape and reel/440 pcs	<b>254824</b>
Right Angle Male	5	SMT	green	Tape and reel/440 pcs	<b>254825</b>
Right Angle Male	5	SMT	red	Tape and reel/440 pcs	<b>254826</b>
Right Angle Male	6	SMT	black	Tape and reel/440 pcs	<b>254699</b>
Right Angle Male	6	SMT	blue	Tape and reel/440 pcs	<b>254700</b>
Right Angle Male	6	SMT	green	Tape and reel/440 pcs	<b>254701</b>
Right Angle Male	6	SMT	red	Tape and reel/440 pcs	<b>254702</b>
Right Angle Male	8	SMT	black	Tape and reel/440 pcs	<b>284121</b>
Right Angle Male	8	SMT	blue	Tape and reel/440 pcs	<b>284122</b>
Right Angle Male	8	SMT	green	Tape and reel/440 pcs	<b>284123</b>
Right Angle Male	8	SMT	red	Tape and reel/440 pcs	<b>284124</b>



ERMEC, S.L. BARCELONA  
C/ Francesc Teixidó, 22  
E-08918 Badalona  
(Spain)

Tel.: (+34) 902 450 160  
Fax: (+34) 902 433 088  
[info@ermec.com](mailto:info@ermec.com)  
[www.ermec.com](http://www.ermec.com)

ERMEC, S.L. MADRID  
C/ Sagasta, 8, 1ª planta  
E-28004 Madrid  
(Spain)

PORTUGAL  
[portugal@ermec.com](mailto:portugal@ermec.com)  
BILBAO  
[bilbao@ermec.com](mailto:bilbao@ermec.com)

# 2.54 mm Single Row Connectors (SRC) MaxiBridge™

## Vertical Male Connectors



### Dimensional Drawing 5 Pin Version

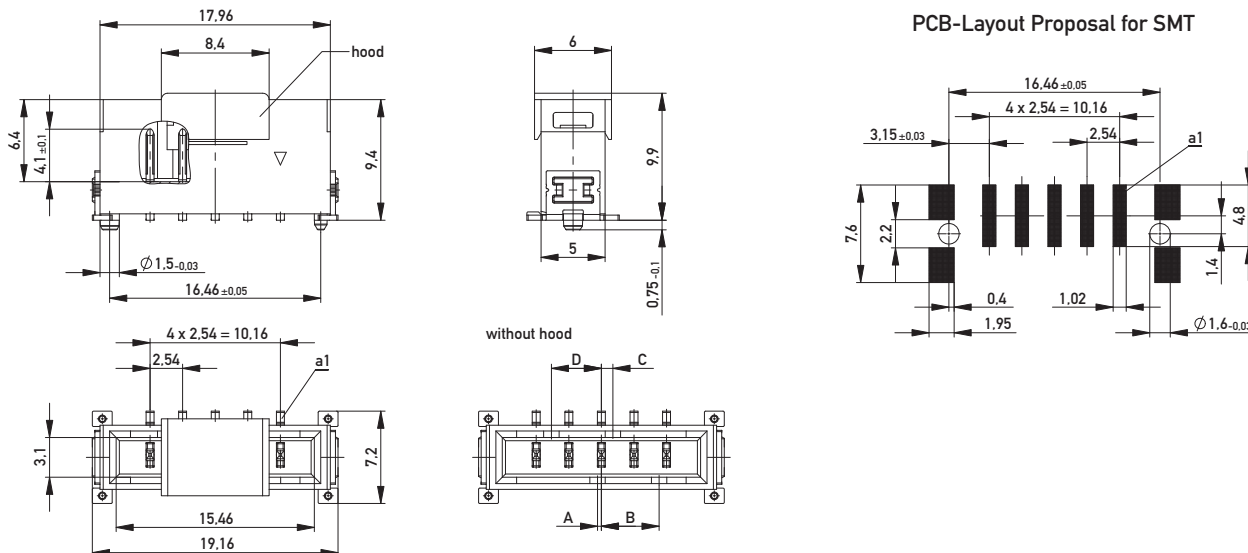

254834		red	3.9	0.9	4.5	0.3
254833		green	2.7	2.1	3.3	1.5
254832		blue	1.5	3.3	2.1	2.7
254831		black	0.3	4.5	0.9	3.9
Part-No.	Coding	Color	A	B	C	D

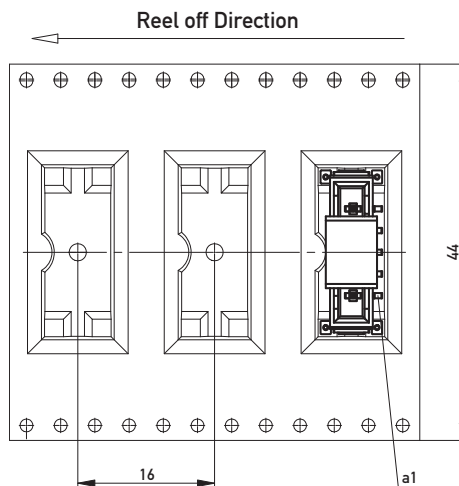
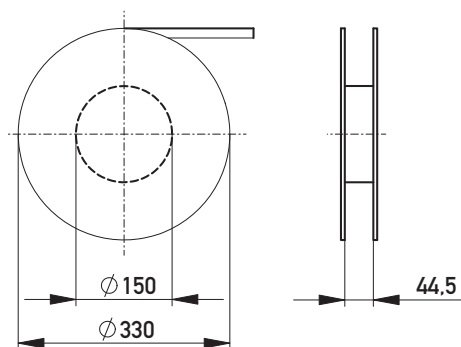

**ERMEC**  
www.ermec.com  
Distribución de componentes  
eléctricos y electrónicos

Tel.: (+34) 902 450 160  
Fax: (+34) 902 433 088  
[ermec@ermec.com](mailto:ermec@ermec.com)  
[www.ermec.com](http://www.ermec.com)

## 2.54 mm Single Row Connectors (SRC) MaxiBridge™

### Vertical Male Connectors



#### Ordering Information

Configuration	Number of Pins	Termination	Coding	Packaging/Unit	Part Number
Vertical Male	2	SMT	black	Tape and reel/320 pcs	<b>294645</b>
Vertical Male	2	SMT	blue	Tape and reel/320 pcs	<b>294646</b>
Vertical Male	2	SMT	green	Tape and reel/320 pcs	<b>294647</b>
Vertical Male	2	SMT	red	Tape and reel/320 pcs	<b>294648</b>
Vertical Male	3	SMT	black	Tape and reel/320 pcs	<b>284656</b>
Vertical Male	3	SMT	blue	Tape and reel/320 pcs	<b>284657</b>
Vertical Male	3	SMT	green	Tape and reel/320 pcs	<b>284658</b>
Vertical Male	3	SMT	red	Tape and reel/320 pcs	<b>284659</b>
Vertical Male	5	SMT	black	Tape and reel/320 pcs	<b>254831</b>
Vertical Male	5	SMT	blue	Tape and reel/320 pcs	<b>254832</b>
Vertical Male	5	SMT	green	Tape and reel/320 pcs	<b>254833</b>
Vertical Male	5	SMT	red	Tape and reel/320 pcs	<b>254834</b>
Vertical Male	6	SMT	black	Tape and reel/320 pcs	<b>254707</b>
Vertical Male	6	SMT	blue	Tape and reel/320 pcs	<b>254708</b>
Vertical Male	6	SMT	green	Tape and reel/320 pcs	<b>254709</b>
Vertical Male	6	SMT	red	Tape and reel/320 pcs	<b>254710</b>
Vertical Male	8	SMT	black	Tape and reel/320 pcs	<b>294649</b>
Vertical Male	8	SMT	blue	Tape and reel/320 pcs	<b>294650</b>
Vertical Male	8	SMT	green	Tape and reel/320 pcs	<b>294651</b>
Vertical Male	8	SMT	red	Tape and reel/320 pcs	<b>294652</b>



ERMEC, S.L. BARCELONA  
C/ Francesc Teixidó, 22  
E-08918 Badalona  
(Spain)

Tel.: (+34) 902 450 160  
Fax: (+34) 902 433 088  
[info@ermec.com](mailto:info@ermec.com)  
[www.ermec.com](http://www.ermec.com)

ERMEC, S.L. MADRID  
C/ Sagasta, 8, 1ª planta  
E-28004 Madrid  
(Spain)

PORTUGAL  
[portugal@ermec.com](mailto:portugal@ermec.com)  
BILBAO  
[bilbao@ermec.com](mailto:bilbao@ermec.com)

# 2.54 mm Single Row Connectors (SRC) MaxiBridge™

## Vertical Female Connectors



### Dimensional Drawing 5 Pin Version

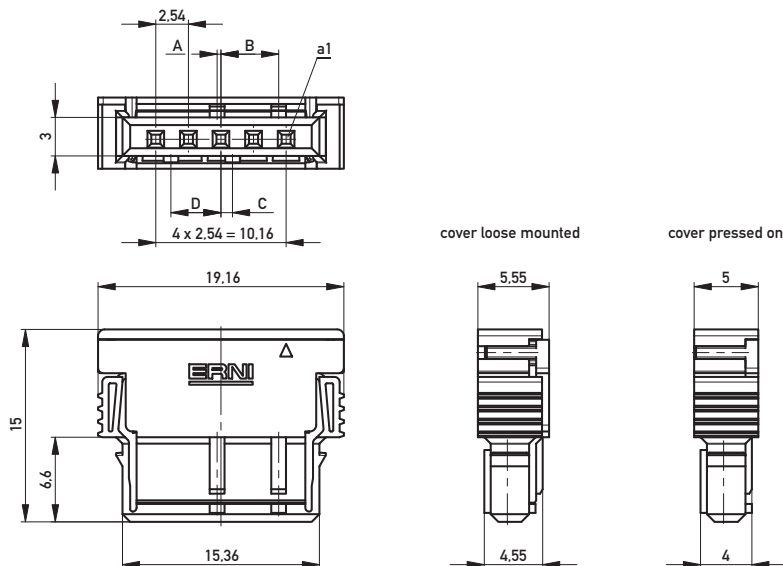

254830		red	3.9	0.9	4.5	0.3
254829		green	2.7	2.1	3.3	1.5
254828		blue	1.5	3.3	2.1	2.7
254827		black	0.3	4.5	0.9	3.9
Part-No.	Coding	Color	A	B	C	D

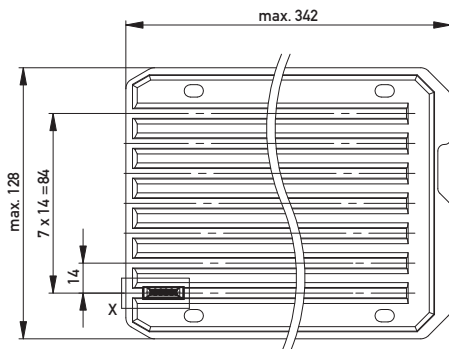

ERMEC, S.L. BARCELONA  
C/ Francesc Teixidó, 22  
E-08918 Badalona  
(Spain)

Tel.: (+34) 902 450 160  
Fax: (+34) 902 433 088  
[info@ermec.com](mailto:info@ermec.com)  
[www.ermec.com](http://www.ermec.com)

ERMEC, S.L. MADRID  
C/ Sagasta, 8, 1ª planta  
E-28004 Madrid  
(Spain)

PORTUGAL  
[portugal@ermec.com](mailto:portugal@ermec.com)  
BILBAO  
[bilbao@ermec.com](mailto:bilbao@ermec.com)

## 2.54 mm Single Row Connectors (SRC) MaxiBridge™

### Vertical Female Connectors



#### Ordering Information

Configuration	Number of Pins	Termination	Coding	Packaging/Unit	Part Number
Vertical Female	2	crimp	black	Tray/182 pcs	284044
Vertical Female	2	crimp	blue	Tray/182 pcs	284045
Vertical Female	2	crimp	green	Tray/182 pcs	284046
Vertical Female	2	crimp	red	Tray/182 pcs	284047
Vertical Female	3	crimp	black	Tray/154 pcs	284048
Vertical Female	3	crimp	blue	Tray/154 pcs	284049
Vertical Female	3	crimp	green	Tray/154 pcs	284050
Vertical Female	3	crimp	red	Tray/154 pcs	284051
Vertical Female	5	crimp	black	Tray/112 pcs	254827
Vertical Female	5	crimp	blue	Tray/112 pcs	254828
Vertical Female	5	crimp	green	Tray/112 pcs	254829
Vertical Female	5	crimp	red	Tray/112 pcs	254830
Vertical Female	6	crimp	black	Tray/96 pcs	254703
Vertical Female	6	crimp	blue	Tray/96 pcs	254704
Vertical Female	6	crimp	green	Tray/96 pcs	254705
Vertical Female	6	crimp	red	Tray/96 pcs	254706
Vertical Female	8	crimp	black	Tray/77 pcs	284117
Vertical Female	8	crimp	blue	Tray/77 pcs	284118
Vertical Female	8	crimp	green	Tray/77 pcs	284119
Vertical Female	8	crimp	red	Tray/77 pcs	284120



ERMEC, S.L. BARCELONA  
C/ Francesc Teixidó, 22  
E-08918 Badalona  
(Spain)

Tel.: (+34) 902 450 160  
Fax: (+34) 902 433 088  
[info@ermec.com](mailto:info@ermec.com)  
[www.ermec.com](http://www.ermec.com)

ERMEC, S.L. MADRID  
C/ Sagasta, 8, 1ª planta  
E-28004 Madrid  
(Spain)

PORTUGAL  
[portugal@ermec.com](mailto:portugal@ermec.com)  
BILBAO  
[bilbao@ermec.com](mailto:bilbao@ermec.com)

## 2.54 mm Single Row Connectors (SRC) MaxiBridge™

### Crimp Contacts and Tools



#### Ordering Information

Contacts	Cable Type	Termination	Packaging	Part Number
Female contact	AWG 16, 18	crimp	Reel/10000 pcs	<b>374043*</b>
Female contact	AWG 16, 18	crimp	Reel/500 pcs	<b>374044*</b>
Female contact	AWG 20, 22	crimp	Reel/10000 pcs	<b>284069</b>
Female contact	AWG 20, 22	crimp	Reel/500 pcs	<b>284070</b>
Female contact	AWG 24, 26	crimp	Reel/10000 pcs	<b>374038*</b>
Female contact	AWG 24, 26	crimp	Reel/500 pcs	<b>374039*</b>

Maximum cable diameter 2 mm.

Tool	Cable Type	Packaging	Part Number
Hand Crimp	AWG 16, 18	1 pcs	<b>992215*</b>
Hand Crimp	AWG 20, 22	1 pcs	<b>952050</b>
Hand Crimp	AWG 24, 26	1 pcs	<b>992216*</b>

The tools are designed for use with contact reels (500 contacts per reel) only.

\* Available in October 2010.

Tool	Part Number
Crimp Applicator, mechanical, usable on automatic crimp processing systems or on bench-top presses	<b>041171</b>

More information about crimp applicators on request.



**ERMEC, S.L. BARCELONA**  
C/ Francesc Teixidó, 22  
E-08918 Badalona  
(Spain)

Tel.: (+34) 902 450 160  
Fax: (+34) 902 433 088  
[info@ermec.com](mailto:info@ermec.com)  
[www.ermec.com](http://www.ermec.com)

**ERMEC, S.L. MADRID**  
C/ Sagasta, 8, 1ª planta  
E-28004 Madrid  
(Spain)

**PORTUGAL**  
[portugal@ermec.com](mailto:portugal@ermec.com)  
**BILBAO**  
[bilbao@ermec.com](mailto:bilbao@ermec.com)

## 2.54 mm Single Row Connectors (SRC)

### MaxiBridge™

#### Cable Assemblies



#### Dimensional Drawing

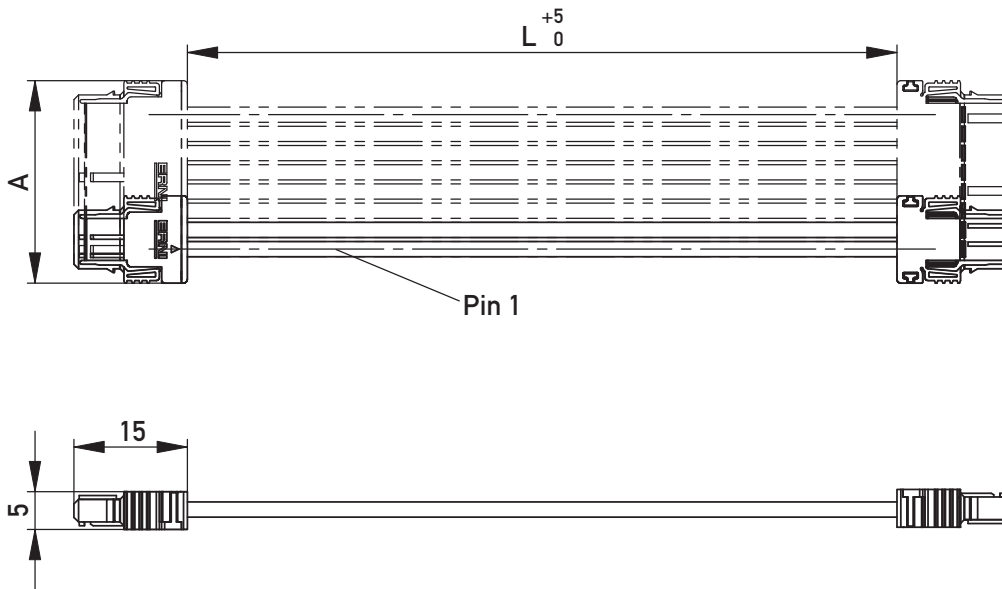

No. of Pins	A
2	11,54
3	14,08
5	19,16
6	21,7
8	26,78



ERMEC, S.L. BARCELONA  
C/ Francesc Teixidó, 22  
E-08918 Badalona  
(Spain)

Tel.: (+34) 902 450 160  
Fax: (+34) 902 433 088  
[info@ermec.com](mailto:info@ermec.com)  
[www.ermec.com](http://www.ermec.com)

ERMEC, S.L. MADRID  
C/ Sagasta, 8, 1ª planta  
E-28004 Madrid  
(Spain)

PORTUGAL  
[portugal@ermec.com](mailto:portugal@ermec.com)  
BILBAO  
[bilbao@ermec.com](mailto:bilbao@ermec.com)

## 2.54 mm Single Row Connectors (SRC)

### MaxiBridge™

#### Cable Assemblies



#### Ordering Information

Number of Pins	Length (mm)	Cable Type (AWG 20)	Connector 1	Connector 2	Class	Part Number
2	500	PVC	Vertical Female, black	Vertical Female, black	1	167355
2	1000	PVC	Vertical Female, black	Vertical Female, black	1	167356
2	1500	PVC	Vertical Female, black	Vertical Female, black	1	167357
2	2000	PVC	Vertical Female, black	Vertical Female, black	1	167358
3	500	PVC	Vertical Female, black	Vertical Female, black	1	167359
3	1000	PVC	Vertical Female, black	Vertical Female, black	1	167360
3	1500	PVC	Vertical Female, black	Vertical Female, black	1	167361
3	2000	PVC	Vertical Female, black	Vertical Female, black	1	167362
5	500	PVC	Vertical Female, black	Vertical Female, black	1	167363
5	1000	PVC	Vertical Female, black	Vertical Female, black	1	167364
5	1500	PVC	Vertical Female, black	Vertical Female, black	1	167365
5	2000	PVC	Vertical Female, black	Vertical Female, black	1	167366
6	500	PVC	Vertical Female, black	Vertical Female, black	1	167367
6	1000	PVC	Vertical Female, black	Vertical Female, black	1	167368
6	1500	PVC	Vertical Female, black	Vertical Female, black	1	167369
6	2000	PVC	Vertical Female, black	Vertical Female, black	1	167370
8	500	PVC	Vertical Female, black	Vertical Female, black	1	167371
8	1000	PVC	Vertical Female, black	Vertical Female, black	1	167372
8	1500	PVC	Vertical Female, black	Vertical Female, black	1	167373
8	2000	PVC	Vertical Female, black	Vertical Female, black	1	167374

Other configurations on request.



ERMEC, S.L. BARCELONA  
C/ Francesc Teixidó, 22  
E-08918 Badalona  
(Spain)

Tel.: (+34) 902 450 160  
Fax: (+34) 902 433 088  
[info@ermec.com](mailto:info@ermec.com)  
[www.ermec.com](http://www.ermec.com)

ERMEC, S.L. MADRID  
C/ Sagasta, 8, 1ª planta  
E-28004 Madrid  
(Spain)

PORTUGAL  
[portugal@ermec.com](mailto:portugal@ermec.com)  
BILBAO  
[bilbao@ermec.com](mailto:bilbao@ermec.com)



# 2.54 mm Single Row Connectors (SRC) MaxiBridge™

## Part Number Index



Part Number	Page	Part Number	Page
041171	12	284044	11
167355	14	284045	11
167356	14	284046	11
167357	14	284047	11
167358	14	284048	11
167359	14	284049	11
167360	14	284050	11
167361	14	284051	11
167362	14	284052	7
167363	14	284053	7
167364	14	284054	7
167365	14	284055	7
167366	14	284069	12
167367	14	284070	12
167368	14	284117	11
167369	14	284118	11
167370	14	284119	11
167371	14	284120	11
167372	14	284121	7
167373	14	284122	7
167374	14	284123	7
234832	7	284124	7
234833	7	284656	9
234834	7	284657	9
234835	7	284658	9
254699	7	284659	9
254700	7	294645	9
254701	7	294646	9
254702	7	294647	9
254703	11	294648	9
254704	11	294649	9
254705	11	294650	9
254706	11	294651	9
254707	9	294652	9
254708	9	374038	12
254709	9	374039	12
254710	9	374043	12
254823	7	374044	12
254824	7	952050	12
254825	7	992215	12
254826	7	992216	12
254827	11		
254828	11		
254829	11		
254830	11		
254831	9		
254832	9		
254833	9		
254834	9		



**ERMEC, S.L. BARCELONA**  
C/ Francesc Teixidó, 22  
E-08918 Badalona  
(Spain)

**Tel.: (+34) 902 450 160**  
**Fax: (+34) 902 433 088**  
[info@ermec.com](mailto:info@ermec.com)  
[www.ermec.com](http://www.ermec.com)

**ERMEC, S.L. MADRID**  
C/ Sagasta, 8, 1ª planta  
E-28004 Madrid  
(Spain)

**PORTUGAL**  
[portugal@ermec.com](mailto:portugal@ermec.com)  
**BILBAO**  
[bilbao@ermec.com](mailto:bilbao@ermec.com)





Member



VMEbus INTERNATIONAL TRADE ASSOCIATION



ERMEC, S.L. BARCELONA  
C/ Francesc Teixidó, 22  
E-08918 Badalona  
(Spain)



Tel.: (+34) 902 450 160  
Fax: (+34) 902 433 088  
[info@ermec.com](mailto:info@ermec.com)  
[www.ermec.com](http://www.ermec.com)

ERMEC, S.L. MADRID  
C/ Sagasta, 8, 1ª planta  
E-28004 Madrid  
(Spain)

PORTUGAL  
[portugal@ermec.com](mailto:portugal@ermec.com)  
BILBAO  
[bilbao@ermec.com](mailto:bilbao@ermec.com)



**ERMEC, S.L. BARCELONA** Tel.: (+34) 902 450 160  
C/ Francesc Teixidó, 22 Fax: (+34) 902 433 088  
E-08918 Badalona  [info@ermec.com](mailto:info@ermec.com)  
(Spain) [www.ermec.com](http://www.ermec.com)  
Distribución de componentes eléctricos y electrónicos

**ERMEC, S.L. MADRID**  
C/ Sagasta, 8, 1ª planta  
E-28004 Madrid  
(Spain)

**PORTUGAL**  
[portugal@ermec.com](mailto:portugal@ermec.com)  
**BILBAO**  
[bilbao@ermec.com](mailto:bilbao@ermec.com)

**ERNI Electronics GmbH**

Seestrasse 9  
73099 Adelberg/Germany  
Tel +49 7166 50-0  
Fax +49 7166 50-282  
info@erni.de

Europe South America Africa Japan

**ERNI Electronics, Inc.**

2201 Westwood Ave  
Richmond, VA 23230/USA  
Tel +1 804 228-4100  
Fax +1 804 228-4099  
info.usa@erni.com

North America Canada Mexico

**ERNI Asia Holding Pte Ltd.**

Blk 4008 Ang Mo Kio Avenue 10  
#04-01/02 Techplace I  
Singapore 569625  
Tel +65 6 555 5885  
Fax +65 6 555 5995  
info@erni-asia.com

Asia

[www.erni.com](http://www.erni.com)

© ERNI Electronics GmbH 2010 • Printed in Germany. A policy of continuous improvement is followed and the right to alter any published data without notice is reserved.  
ERNI®, MicroStac®, MicroSpeed®, MiniBridge®, MaxiBridge®, ERmet®, ERmet ZD®, ERbic® and ERNIPRESS® are trademarks (registered or applied for in various countries) of ERNI Electronics GmbH.