

Push it... get the hapital feedback

th▶contact



TP7 the PIEZO push button

- Vibration feedback
- Piezo electronic without auxiliary energy
- Pre-wired or faston terminals
- Housing in different colors



Further products

- Rocker switches
- Momentary switches
- Solenoids
- Motors



TP7

Dimensions (mm) Ø 36 x 32

- Characteristics
- piezo technology
 - momentary
 - sealed (IP67)
 - illumination in two colors
 - solid state output
 - NO

Rating 3 to 35 VAC/VDC, 200 mA

Panel cut-out (mm) Ø 30,3

- Actuator
- housing and button in different colors
 - button with symbols

Typical Segments

- Building Automation & Security
- Industrial Equipment
- Transportation
- Traffic

Typical Applications

- Alarm call point
- Control panel
- Special vehicle
- Traffic lights



ERMEC, S.L. BARCELONA
C/ Francesc Teixidó, 22
E-08918 Badalona
(Spain)

Tel.: (+34) 902 450 160
Fax: (+34) 902 433 088
info@ermec.com
www.ermec.com

ERMEC, S.L. MADRID
C/ Sagasta, 8, 1ª planta
E-28004 Madrid
(Spain)

PORTUGAL
portugal@ermec.com
BILBAO
bilbao@ermec.com

Saia-Burgess Halver GmbH

Weissenpferd 9, 58553 Halver
T +49 23 53 91 11 33, F +49 23 53 91 12 99
andreas.aldermann@johnsonelectric.com, www.th-contact.com



innovating motion

Technical Data

Circuit diagram

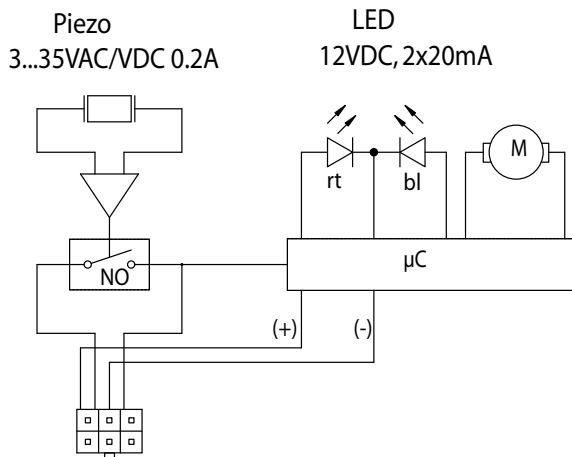

The piezo sensor converts pressure into voltage signals. These analogue voltage signals are then processed within the switch to form switching signals, using field effect transistors (FET).

Due to the internal resistor, the circuit state is dependent upon actuating force and speed, means of operation and the discharge time of the R-C system. Standard digital or relay technology can be employed to create individual timed delay. Flip-flop and power amplification circuits.

Dimensions (mm)

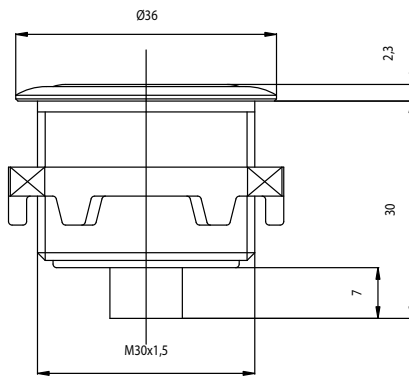

Panel-cut-out (mm)

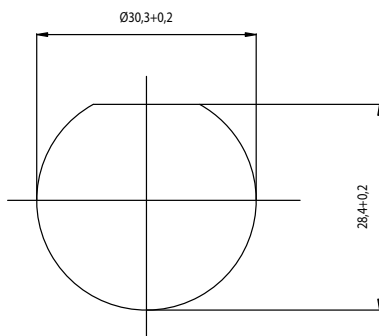

Specifications

| | |
|-----------------------|---|
| Mechanism | Piezo electronic, without auxilliary energy |
| Mounting | Central fixing from the rear with lock nut |
| Housing material | Anodised aluminium |
| Illumination | LED's |
| Temperature range | -40 °C to +85 °C |
| Contact resistance | < 10 Ohm (on) |
| Insulation resistance | > 5M Ohm (off) |



ERMEC, S.L. BARCELONA
C/ Francesc Teixidó, 22
E-08918 Badalona
(Spain)

Tel.: (+34) 902 450 160
Fax: (+34) 902 433 088
info@ermec.com
www.ermec.com

ERMEC, S.L. MADRID
C/ Sagasta, 8, 1ª planta
E-28004 Madrid
(Spain)

PORTUGAL
portugal@ermec.com
BILBAO
bilbao@ermec.com