

MOCON brings Science
to the Art of Leak
Detection using the
new InFlux™ method

3 in 1

First of its Kind

Determines leak hole size
Analyzes O₂ headspace
Measures package volume

NEW!

**PAC CHECK®
Package Integrity
Analyzer**

Patent pending AccuLeak™ technology
determines the absolute leak size
of your package



**Benchtop
MODEL 840**

**Portable
MODEL 820**



Equipos de control de calidad

Tel.: (+34) 902 450 160

Fax: (+34) 902 433 088

ermec@ermec.net

www.ermec.net

mocon®

*The Gas Detection, Analysis, and
Control Specialists*

Combination

Leak Detector • O₂ Headspace Analyzer • Measures Package Volume

Never before has one system given you answers critical in the determination of package shelf-life... fast and accurately!

For use as a research & development tool in package shelf-life studies as well as a quality control device for the measurement of important headspace and leak parameters.



**Benchtop
PAC CHECK® MODEL 840**



Features

- Ability to measure in one quick analysis, three critical variables which determine shelf life
- Calculates the real and absolute leak size in a flexible or semi-rigid package
- Ability to detect channel leaks from 0.0008 - 0.009" (20-229 micron) diameter at 1/4" (0.64 cm) length and even smaller pinhole leaks.
- Certified NIST traceable leaks for instrument validation
- Benchtop Model 840 with high speed pump for fast analysis of large packages
- Portable Model 820 with a rechargeable battery for online and in-store analysis
- Flo -Smart™ technology detects any blockage of sample flow into the instrument
- SafePoint™ probe tip, reusable blunt point pierces the package, not skin
- Alarms - Low and High
- Store up to 240 individual product test methods
- Store up to 240 test results that can be sorted by multiple criteria
- Optional PC PAC™ software available

“How much is your package leaking?”

Get the answer for a channel or pin hole leak using MOCON's patent pending InFlux™ method

There are several benefits to the InFlux™ vacuum/flow method utilized in the PAC CHECK Package Integrity Analyzers over traditional positive pressure leak detectors. Benefits to this type of method include:

- Increased sensitivity, accuracy and repeatability
- Eliminates errors caused by package creep, as well as from artificial stresses on package seals
- Leak measurement is not package volume dependent
- Ability to calculate three measurements simultaneously—headspace, leak and volume



Portable
PAC CHECK® MODEL 820



AccuLeak™ Technology

AccuLeak™ is the use of Poiseuille's Law to determine absolute aggregate hole size in your package.

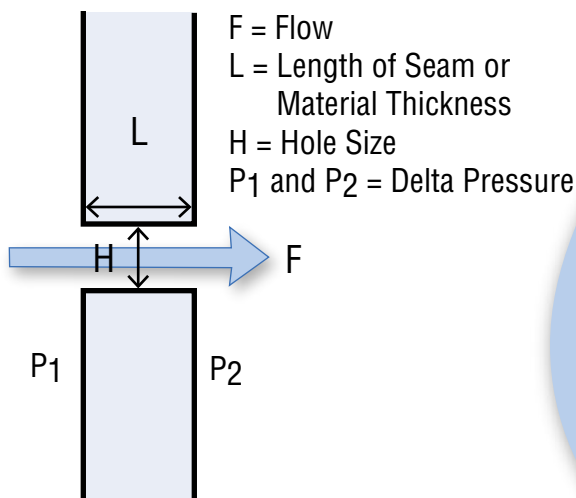

According to Poiseuille's Law, given pressure, flow and hole length (whether material thickness in the case of a pin hole leak, or seam length in the case of a channel leak) **Absolute** aggregate hole size can be determined. With the PAC CHECK Package Integrity Analyzer, material thickness and/or seam length is entered and the analyzer will measure pressure and flow, allowing for the precise determination of absolute aggregate hole size*

*A more detailed discussion on the application of Poiseuille's Law is available from MOCON

PAC CHECK® Models 820/840

Technical Specifications (Preliminary)

O ₂ % Range:	0.01-100%
Accuracy:	+/- 0.1% Absolute or +/- 2% Relative whichever is greater
Volume Range:	0.1 - 13 liters
Accuracy:	+/- 0.03 liters Absolute or +/-2% Relative whichever is greater
Hole Size Range:	1.0 - 9.0 mils (25.4 - 229 micron) at 0.25" (0.64 cm) channel length 0.5 - 5.0 mils(12.7 - 127 micron) at 0.01" (254 micron) channel length
Accuracy:	+/- 0.1 mil Absolute or +/-3% Relative whichever is greater
Max Flow Range:	2,500 cc/min for the Model 820 5,300 cc/min for the Model 840
Pressure Range:	400-800 mmHg
Amb. Temp Range:	10-30C
Amb. Humidity Range:	0-90%RH non-condensating
Power Range:	100-240 volts AC
Frequency Range:	50-60 Hz

5 different languages available

NIST Traceable Leaks

2 sizes of leaks come with the instrument to validate system performance.

3 mil (76.2 micron) channel @ 1/4" (0.64 cm) and a 7 mil (178 micron) channel @ 1/4" (0.64 cm)

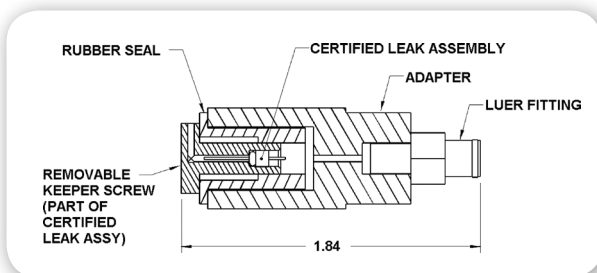

Patent #6,382,011

Specifications may change as part of our program for continuous product improvement.

For more information,
visit our website at
www.mocon.com
or call **763-493-6370** to
speak with a sales specialist

mocon®

7500 Boone Avenue North
Minneapolis, Minnesota 55428
USA
763-493-6370

Optional PC PAC™ Software

Ability to sync product names, user names, test results, and test methods between the instrument and the computer.

Optional Verification Standards

- Volume Standard
- O₂ Calibrated Gas



Equipos de control de calidad

Tel.: (+34) 902 450 160
Fax: (+34) 902 433 088
ermec@ermec.net
www.ermec.net