

# Compact Design, Best for Installing in Auto-Packer

## Zirconia Oxygen Analyzer

Model: LF-200

Zirconia O<sub>2</sub> Analyzer Model LF-200 is developed for automatic packaging machine, based on our long experience of O<sub>2</sub> analyzers for food packaging industry.

It has achieved its higher durability due to equipped Toray unique zirconia mini-sensor available for long-term stable and precise measurement, and O<sub>2</sub> sensor protection system.

It is most suitable to be installed in various auto-packer for food or medicine with simple operation and compact size.

### Features

- **Remove Oil**  
New type filter is good for oil-mist.  
Direct filter- replacement is available.
- **Suction Pump Protection Function**  
It is available to avoid trouble caused by air blow cleaning and protect pump.
- **Field Calibration**  
Field calibration is available ( calibration kit is option).
- **Fast Response**  
Internal piping flow minimizing the measurement gas gathering.
- **Power Supply**  
AC200V is the standard to be easily installed in the packer(AC100V is option).



※Portable Type(Optional)

### Measurement Principles

Toray's Zirconia Oxygen Analyzers determine oxygen concentration using the conductivity of a zirconia ceramic cell. Zirconia ceramic cells only allow oxygen ions to pass through at high temperatures. With reference gas on one side and sample gas on the other, oxygen ions move from the side with the highest concentration of oxygen to that with the lowest concentration. The movement of ions generates an Electro Motive Force, which can be measured to determine the oxygen content. This is in accordance with the so-called Nernst Equation.

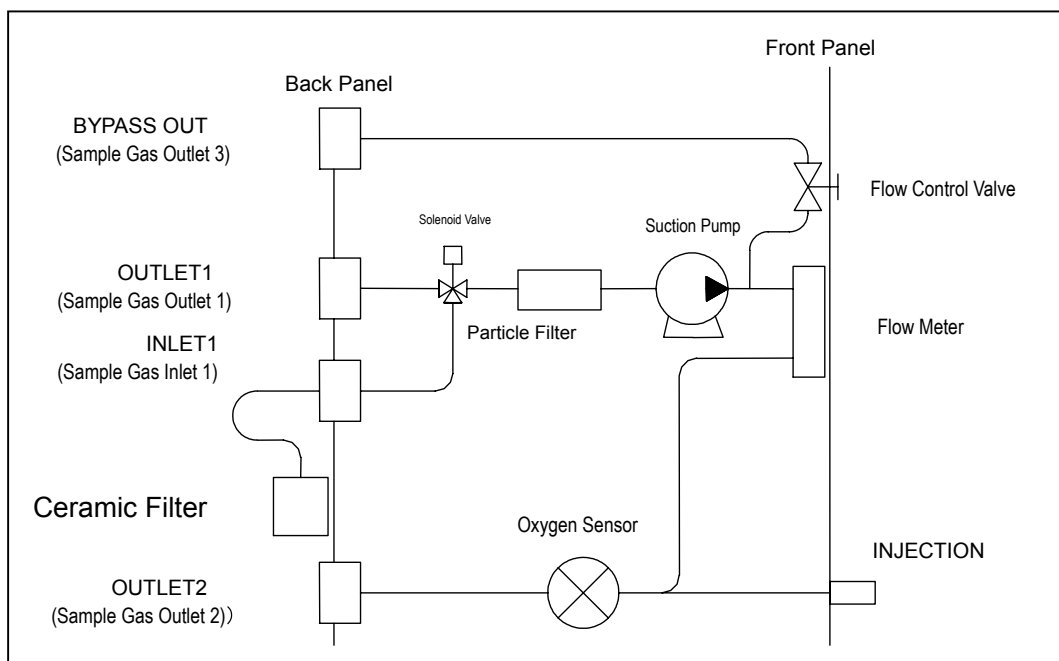

LF-200 Internal Flow

# Specifications

## 1. Instruments Specifications

Type	Panel Mounted(Portable type is option)	
Display	Digital 4 Digits(Concentration Display)	
Meas. Range	1ppm~100vol%O <sub>2</sub>	
Display	0- 1000ppm/1/10/100% Auto Range	
Analog output	0-0.5/5/10/100% Selectable Fixed range ※1000ppm range is reference value. (No Guarantee)	
Sampling Method	Continuous suction by built-in pump & Injection ※Injection method is reference value. (No Guarantee)	
Supplied Gas	1000ml/min	
Sensor Gas	60±10ml/min	
Gas Connection	INLET(Filter In)	Rc1/8
	BYPASSOUT(Bypass Outlet)	Rc1/4
	OUTLET1(Sample Gas)	Rc1/4
	OUTLET2(Sample Gas)	Rc1/4
Reference Gas	Atmospheric Gas	
Weight	Approx. 7.0kg	
Color	Silver-metallic(Front & Rear Panel) Non-painted Stainless steel(Cover)	

## 2. Performance

Repeatability	±1%FS(more than 0-1% range) ±2%FS(less than 0-1% range) (0-1000ppm is no guarantee)
Air Point Stability	±0.5%FS/24h

## 3. Engineering Specifications

Meas. Value Output	External Output: DC4~20mA
Concentration Alarm Output	LED Display(upper/lower limit) Contact Output: 2a Individual Output Contact Capacity: AC30V DC30V, 0.5A
Self Diagnosis	Warm-up Error, Thermocouple Error, Over Heat Error CPU Error, Furnace Error Asymmetry Potential Error Sensor Resistance Value Error AIR Point Calibration Error SPAN Point Calibration Error
Sample Gas Conditions	Neither Flammable, Halogen, Silica, Corrosive nor Waterdrop shall be contained. Pressure: Less than 0.014MPa Flow: 1000~2000ml/min Temperature: Less than 40°C Humidity: Dew point shall be lower than ambient temperature
Power Source	Voltage: AC200V Terminal Connect Frequency: 50/60Hz
Installation Conditions	Location: Indoor, Non Explosion Area Ambient Temperature: 0~40°C Ambient Humidity: 45~85%RH, No dew generated
Option	RS-232 Output Active Carbon Filter, Cotton Filter

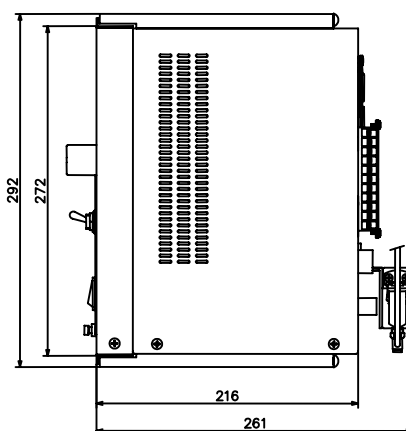
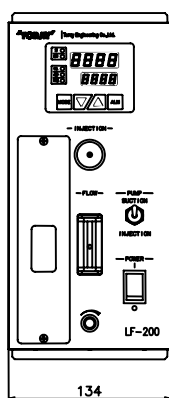

### Cautions

For your safety and correct operation, please read the instruction manual carefully before use.

■The design and specifications may be changed without notice for improvement.

■Please send any questions or requests to the following address.

**ERMEC**

Equipos de control de calidad

**PAUL LIPPKE HANDELS-GMBH**  
Prozess- und Laborsysteme  
Willi-Brückner-Strasse 1  
D-56564 Neuwied

Tel.: (+34) 902 450 160

Fax: (+34) 902 433 088

[ermec@ermec.net](mailto:ermec@ermec.net)

[www.ermec.net](http://www.ermec.net)

Fon +49.2631.3933-0

Fax +49.2631.3933-33

Email: [info@lippke.com](mailto:info@lippke.com)

Internet: [www.lippke.com](http://www.lippke.com)