

EMD

DRIVE SYSTEMS

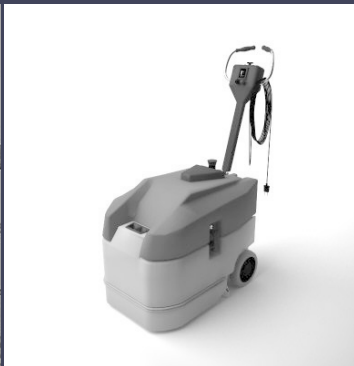

motion solutions for
leisure, mobility and
industrial applications



ERMEC, S.L. BARCELONA
C/ Francesc Teixidó, 22
E-08918 Badalona
(Spain)

Tel.: (+34) 902 450 160
Fax: (+34) 902 433 088
info@ermec.com
www.ermec.com

ERMEC, S.L. MADRID
C/ Sagasta, 8, 1ª planta
E-28004 Madrid
(Spain)

PORTUGAL
portugal@ermec.com
BILBAO
bilbao@ermec.com

PARVALUX®

www.parvalux.com

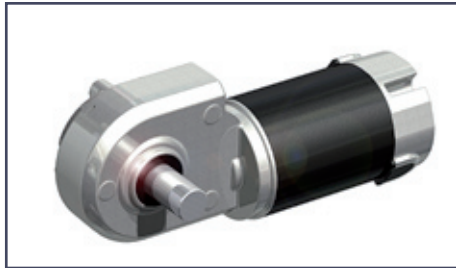

STAIR LIFT
unique worm-spur double reduction gearbox
delivering 124Nm of torque in compact design

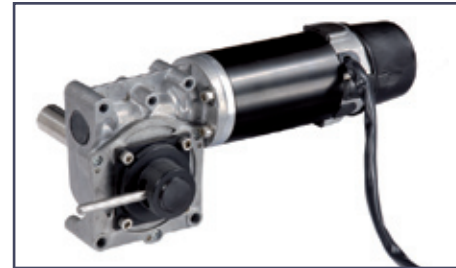

WHEELCHAIR POWER ASSIST
sealed worm gearbox with
de-clutch and brake options



POWERED GOLF CADDY
lightweight worm plastic gearbox
with hollow shaft option



MOBILITY SCOOTER / GOLF RIDE-ON
robust gearbox with black powder-coated
finish, brake and special shaft



POWERED GOLF CADDY
lightweight plastic gearbox with differential
gearing for improved manoeuvrability



DOOR OPENER
PM44-50 fitted with spade connectors
and compact worm gearbox



CARAVAN MOVER
bespoke worm unit with ergonomic chassis and
integrated housing for easy installation



FLOOR CLEANER
rare-earth motor fitted with long-life
sealed worm gearbox and brake

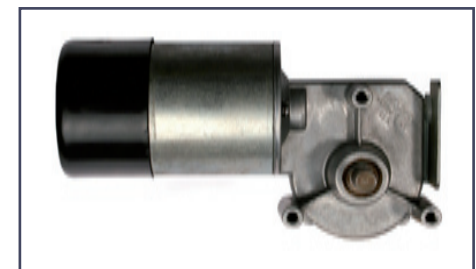

MOBILITY AID
worm gearbox with 3-point fixing
for wheelchair vehicle access winch



PM44-25 / PM44-38 / PM44-50 permanent magnet DC motor

standard motor configured and customised for your application

MOTOR	Permanent magnet DC
SPEED	1500 - 8000 rpm
PROTECTION	IP44 - IP66
POWER	up to 180 Watts
VOLTAGE	12 - 240V DC
INSULATION	Class F
CONSTRUCTION	Ferrite magnets; aluminium end castings; single piece steel body; replaceable carbon brushes; 300mm flying leads; maximum shaft diameter 8mm
EXTRAS	Ventilated motor with internal fan (IP2x); encoder to RoHS standard; 12V or 24V 2Nm failsafe holding brake; dedicated cable harness; spade connectors



	PM44-25			PM44-38			PM44-50		
	Power (W)	Speed (rpm)	Torque (Nm)	Power (W)	Speed (rpm)	Torque (Nm)	Power (W)	Speed (rpm)	Torque (Nm)
Continuous S1 duty (assuming 24V supply)	30	5000	0.057	50	5000	0.095	-	-	-
	30	4000	0.070	50	4000	0.120	65	4000	0.155
	30	3000	0.090	50	3000	0.160	65	3000	0.200
	30	2000	0.140	50	2000	0.240	65	2000	0.310
Intermittent duty S3 30% (assuming 24V supply)	45	5000	0.086	75	5000	0.143	-	-	-
	45	4000	0.107	75	4000	0.179	100	4000	0.239
	45	3000	0.143	75	3000	0.239	100	3000	0.319
	45	2000	0.215	75	2000	0.359	100	2000	0.478



ISO 9001:2000 Certificate No. FM548688

Notes: Designed to operate with PWM controllers.

Graphs are available showing the motor performance throughout the speed range.

This motor may be coupled with many of our standard worm, spur and planetary gearboxes.

For customers who require in excess of 5000 units per year we offer a totally bespoke design service to fit the application; at zero cost premium. This service enables customers to outline any number of mechanical, electrical, environmental or even aesthetic requirements in order to realise their preferred motor-gearbox solution.

To find out more please contact a member of our sales team on +44 (0)1202 512 575 or visit our website at www.parvalux.com for further information.



ERMEC, S.L. BARCELONA
C/ Francesc Teixidó, 22
E-08918 Badalona
(Spain)

Tel.: (+34) 902 450 160
Fax: (+34) 902 433 088
info@ermec.com
www.ermec.com

ERMEC, S.L. MADRID
C/ Sagasta, 8, 1ª planta
E-28004 Madrid
(Spain)

PORTUGAL
portugal@ermec.com
BILBAO
bilbao@ermec.com

PARVALUX

drawing for PM44-25 / PM44-38 / PM44-50 permanent magnet DC motor

standard motor configured and customised for your application

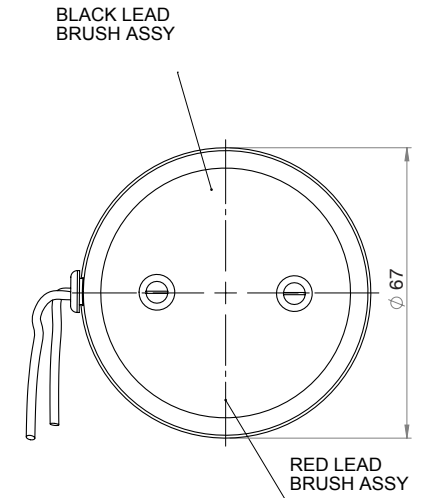
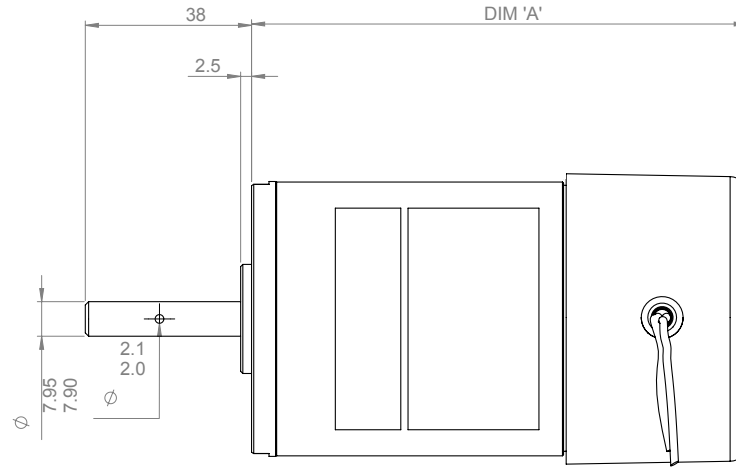
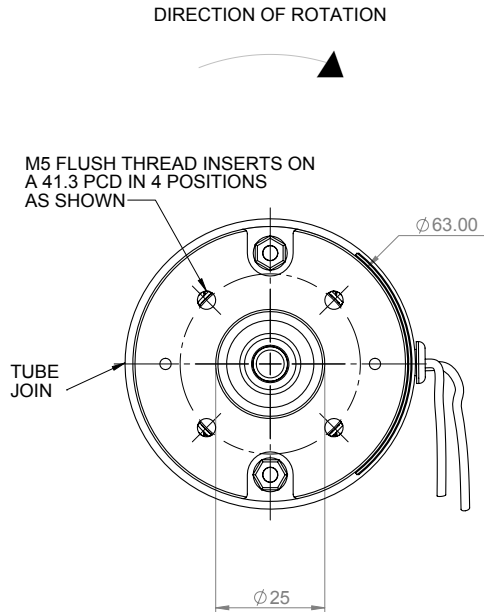

NOTE: WITH THE BRUSH LEAD ASSEMBLYS IN THE POSITIONS AS SHOWN THIS WILL GIVE A CLOCK WISE ROTATION AT THE DRIVE END OF THE MOTOR.

ERMEC
www.ermec.com

ERMEC, S.L. BARCELONA
C/ Francesc Teixidó, 22
E-08918 Badalona
(Spain)

Tel.: (+34) 902 450 160
Fax: (+34) 902 433 088
info@ermec.com
www.ermec.com

ERMEC, S.L. MADRID
C/ Sagasta, 8, 1ª planta
E-28004 Madrid
(Spain)

PORTUGAL
portugal@ermec.com
BILBAO
bilbao@ermec.com

Motor Type	Motor Weight	DIM A (mm)	
		Totally Enclosed	Ventilated
PM44-25	0.8 kg	101	113
PM44-38	1.2kg	114	126
PM44-50	1.3kg	126	138

For customers who require in excess of 5000 units per year we offer a totally bespoke design service to fit the application; at zero cost premium. This service enables customers to outline any number of mechanical, electrical, environmental or even aesthetic requirements in order to realise their preferred motor-gearbox solution. To find out more please contact a member of our sales team on +44 (0)1202 512 575 or visit our website at www.parvalux.com for further information.

PM50-38 / PM50-50 / PM50-63 permanent magnet DC motor

standard motor configured and customised for your application

MOTOR	Permanent magnet DC
SPEED	1500 - 8000 rpm
PROTECTION	IP44 - IP66
POWER	up to 450 Watts
VOLTAGE	12 - 240V DC
INSULATION	Class F
CONSTRUCTION	Ferrite magnets; aluminium end castings; single piece steel body; replaceable carbon brushes; spade connectors; maximum shaft diameter 9.5mm
EXTRAS	Ventilated motor with internal fan (IP2x); encoder to RoHS standard; 12V or 24V 2Nm failsafe holding brake; dedicated cable harness; shaft at both ends



	PM50-38			PM50-50			PM50-63		
	Power (W)	Speed (rpm)	Torque (Nm)	Power (W)	Speed (rpm)	Torque (Nm)	Power (W)	Speed (rpm)	Torque (Nm)
Continuous S1 duty (assuming 24V supply)	91	6400	0.14	110	6300	0.16	135	6200	0.21
	94	5300	0.17	110	5250	0.2	134	5200	0.25
	91	3700	0.24	110	3675	0.28	122	3650	0.33
	93	3000	0.30	104	2500	0.39	120	2970	0.39
	82	1800	0.44	94	1800	0.49	112	1750	0.62
	75	1500	0.47	89	1500	0.56	109	1580	0.67
Intermittent duty S3 30% (assuming 24V supply)	148	6400	0.22	190	6300	0.28	209	6200	0.32
	146	5300	0.26	190	5250	0.34	206	5200	0.37
	139	3700	0.36	190	3675	0.49	188	3650	0.49
	146	3000	0.47	184	2500	0.7	185	2970	0.59
	125	1800	0.66	181	1800	0.96	173	1750	0.94
	112	1500	0.71	160	1500	1.01	169	1580	1.02



Notes: Designed to operate with PWM controllers.

Graphs are available showing the motor performance throughout the speed range.

This motor may be coupled with many of our standard worm, spur and planetary gearboxes.

For customers who require in excess of 5000 units per year we offer a totally bespoke design service to fit the application; at zero cost premium. This service enables customers to outline any number of mechanical, electrical, environmental or even aesthetic requirements in order to realise their preferred motor-gearbox solution.

To find out more please contact a member of our sales team on +44 (0)1202 512 575 or visit our website at www.parvalux.com for further information.

ERMEC
www.ermec.com
ERMEC, S.L. BARCELONA
C/ Francesc Teixidó, 22
E-08918 Badalona
(Spain)

Tel.: (+34) 902 450 160
Fax: (+34) 902 433 088
info@ermec.com
www.ermec.com

ERMEC, S.L. MADRID
C/ Sagasta, 8, 1ª planta
E-28004 Madrid
(Spain)

PORTUGAL
portugal@ermec.com
BILBAO
bilbao@ermec.com

PARVALUX

drawing for PM50-38 / PM50-50 / PM50-63 permanent magnet DC motor

standard motor configured and customised for your application

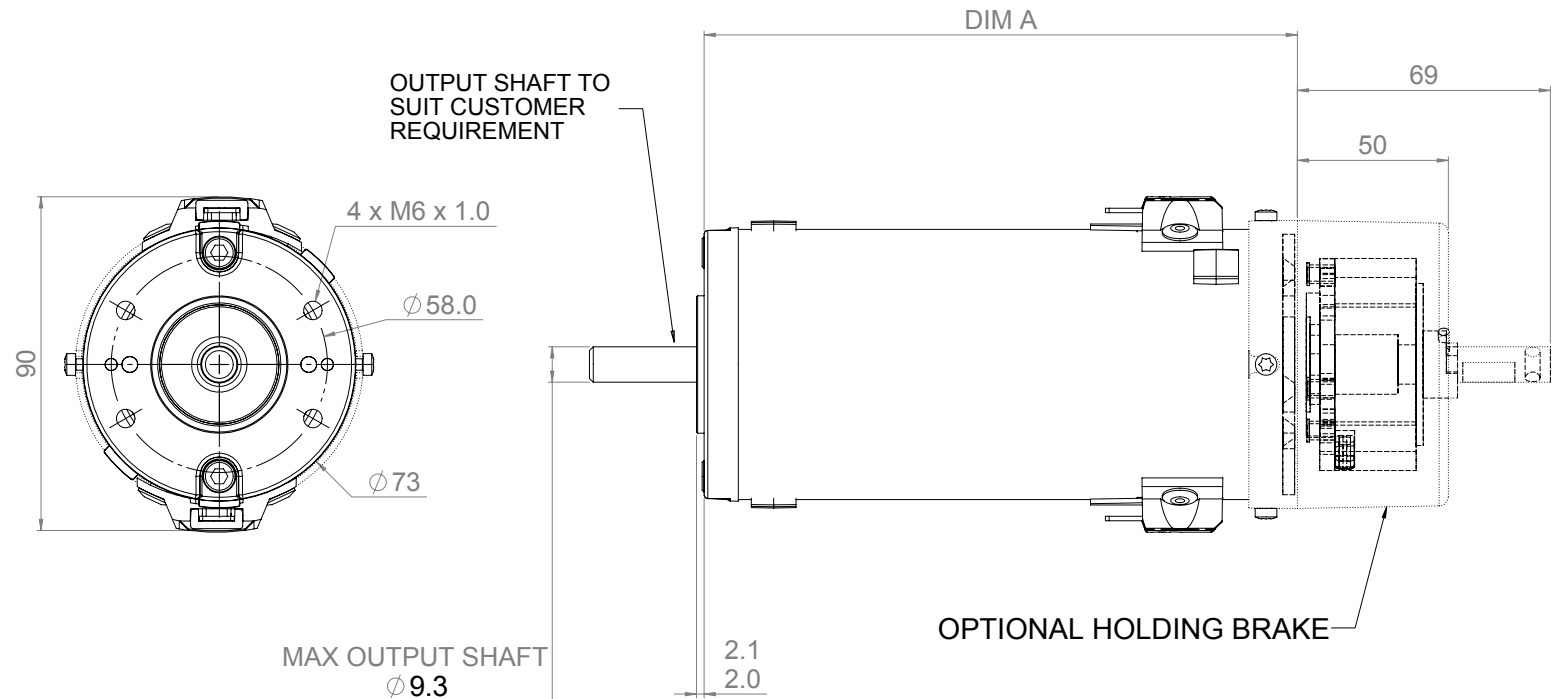

Motor Type	Motor Weight	DIM A (mm)	
		Totally Enclosed	Ventilated
PM50-25	1.9 kg	119	130
PM50-38	1.9kg	130	145
PM50-50	2.0kg	145	155
PM50-63	2.1kg	155	165



ERMEC, S.L. BARCELONA
C/ Francesc Teixidó, 22
E-08918 Badalona
(Spain)

Tel.: (+34) 902 450 160
Fax: (+34) 902 433 088
info@ermec.com
www.ermec.com

ERMEC, S.L. MADRID
C/ Sagasta, 8, 1ª planta
E-28004 Madrid
(Spain)

PORTUGAL
portugal@ermec.com
BILBAO
bilbao@ermec.com

All dimensions are in mm
Many of our drawings are available in
3D format. Please contact us with your
requirements

For customers who require in excess of 5000 units per year we offer a totally bespoke design service to fit the application; at zero cost premium. This service enables customers to outline any number of mechanical, electrical, environmental or even aesthetic requirements in order to realise their preferred motor-gearbox solution. To find out more please contact a member of our sales team on +44 (0)1202 512 575 or visit our website at www.parvalux.com for further information.

PM50-38 / PM50-50 / PM50-63 with GB4 gearbox

standard motor-gearbox configured and customised for your application

MOTOR	Permanent magnet DC	GEARBOX	Worm and wheel
SPEED	1500 - 8000 rpm	RATIOS	12.5:1, 25:1, 30:1, 50:1, 60:1, 75:1
PROTECTION	IP44 - IP66	EFFICIENCY	up to 95%
POWER	up to 450 Watts	MATERIALS	Delrin or phosphor bronze
VOLTAGE	12 - 240V DC	SHAFT	single or double up to 20mm diameter
INSULATION	Class F	CONSTRUCTION	Steel worm shaft; CNC machined aluminium housing; sealed for life; cushioned 3-piece coupling; steel output shaft with 2 ball-bearings
CONSTRUCTION	Ferrite magnets; aluminium end castings; single piece steel body; replaceable carbon brushes; spade connectors	OPTIONS	Stainless steel shaft; black finish; dog clutch
EXTRAS	Ventilated motor with internal fan (IP2x); encoder to RoHS standard; 12V or 24V 2Nm failsafe holding brake		



	PM50-38GB4				PM50-50GB4				RE50-63GB4				Gearbox GB4			
	Power (W)	Speed (rpm)	Torque (Nm)		Power (W)	Speed (rpm)	Torque (Nm)		Power (W)	Speed (rpm)	Torque (Nm)		Ratio	Efficiency†	Momentary overload (Nm)	
			Delrin	Bronze			Delrin	Bronze			Delrin	Bronze			Delrin	Bronze
Continuous S1 duty (assuming 24V supply)	81	512	1.4	1.4	110	504	1.9	1.8	142	496	2.4	2.3	12.5	95%	68	79
	83	424	1.8	1.7	110	420	2.3	2.2	141	416	2.8	2.7	12.5	95%	68	79
	80	296	2.5	2.4	110	294	3.1	3.0	129	292	3.8	3.7	12.5	95%	68	79
	83	212	3.4	3.3	110	210	4.4	4.3	141	208	5.5	5.4	25	90%	73	82
	82	100	6.7	6.6	104	100	9.2	9.1	127	99	9.7	9.5	30	84%	56	76
	82	60	10.4	10.1	104	60	12.8	12.5	127	59	15.2	14.7	50	78%	72	81
	71	30	17.2	16.8	94	30	22.6*	22.2*	118	29	28.1*	27.4	60	76%	57	76
	63	20	22.7*	22.1*	89	20	29.7*	29.3*	115	21	36.8*	35.9*	75	74%	40	45
Intermittent duty S3 30% (assuming 24V supply)	133	512	2.4	2.3	110	504	3.1	3.0	220	496	3.8	3.7	12.5	95%	68	79
	131	424	2.8	2.6	110	420	3.6	3.4	217	416	4.4	4.3	12.5	95%	68	79
	124	296	3.8	3.7	110	294	4.8	4.7	198	292	5.8	5.7	12.5	95%	68	79
	131	212	5.3	5.1	110	210	7.0	6.8	217	208	8.6	8.2	25	90%	73	82
	131	100	10.2	9.9	104	100	12.6	12.3	195	99	15.0*	14.6	30	84%	56	76
	131	60	19.0*	18.6	104	60	21.1	20.7	195	59	23.2*	22.7	50	78%	72	81
	110	30	26.9*	26.1	94	30	35.1*	34.3*	182	29	43.3*	42.1*	60	76%	57	76
	97	20	34.7*	33.9*	89	20	45.8*	45.0*	178	21	-	-	75	74%	40	45



Notes: Designed to operate with PWM controllers.

Graphs are available showing the motor performance throughout the speed range.

The GB4 gearbox is available as an MRO product; for new applications we recommend the GB12 gearbox instead, which offers improved performance with similar dimensions.

For customers who require in excess of 5000 units per year we offer a totally bespoke design service to fit the application; at zero cost premium. This service enables customers to outline any number of mechanical, electrical, environmental or even aesthetic requirements in order to realise their preferred motor-gearbox solution.

To find out more please contact a member of our sales team on +44 (0)1202 512 575 or visit our website at www.parvalux.com for further information.

*Gearbox life may be less than 5000 hours. Contact us for application advice. † Maximum theoretical efficiency.

PM50-38 / PM50-50 / PM50-63 with GB4 gearbox

standard motor-gearbox configured and customised for your application

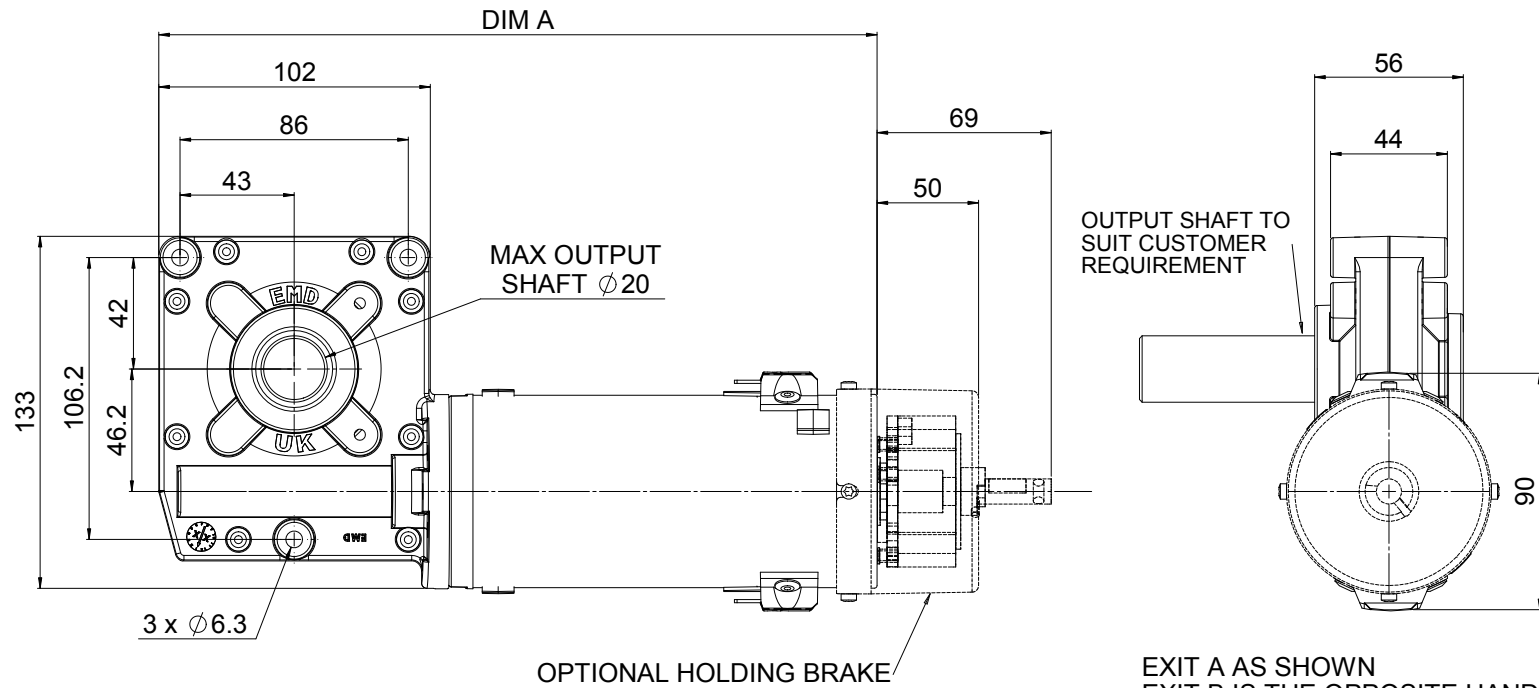

Motor Type	Motor Weight	Gearbox Weight with Delrin	Gearbox Weight with bronze	DIM A	
				Totally Enclosed	Ventilated
PM50-38	1.9 kg	1.0 kg	1.4 kg	240	253
PM50-50	2.0kg	1.0 kg	1.4 kg	252	265
PM50-63	2.1kg	1.0 kg	1.4 kg	265	278

EXIT A AS SHOWN
EXIT B IS THE OPPOSITE HAND

All dimensions are in mm
Many of our drawings are available in 3D format. Please contact us with your requirements

ERMEC ERMEC, S.L. BARCELONA
C/ Francesc Teixidó, 22
E-08918 Badalona
(Spain)

Tel.: (+34) 902 450 160
Fax: (+34) 902 433 088
info@ermec.com
www.ermec.com

ERMEC, S.L. MADRID
C/ Sagasta, 8, 1ª planta
E-28004 Madrid
(Spain)

PORTUGAL
portugal@ermec.com
BILBAO
bilbao@ermec.com

For customers who require in excess of 5000 units per year we offer a totally bespoke design service to fit the application; at zero cost premium. This service enables customers to outline any number of mechanical, electrical, environmental or even aesthetic requirements in order to realise their preferred motor-gearbox solution. To find out more please contact a member of our sales team on +44 (0)1202 512 575 or visit our website at www.parvalux.com for further information.

PM50-38 / PM50-50 / PM50-63 with GB12 gearbox

standard motor-gearbox configured and customised for your application

MOTOR	Permanent magnet DC	GEARBOX	Worm and wheel
SPEED	1500 - 8000 rpm	RATIOS	12.5:1, 25:1, 30:1, 50:1, 60:1, 75:1
PROTECTION	IP44 - IP66	EFFICIENCY	up to 95%
POWER	up to 450 Watts	MATERIALS	Delrin or phosphor bronze
VOLTAGE	12 - 240V DC	SHAFT	single or double up to 25mm diameter
INSULATION	Class F	CONSTRUCTION	Steel worm shaft; CNC machined aluminium housing; sealed for life - maintenance free; cushioned 1-piece coupling; steel output shaft with 2 ball-bearings
CONSTRUCTION	Ferrite magnets; aluminium end castings; single piece steel body; replaceable carbon brushes; spade connectors	OPTIONS	Stainless steel shaft; black finish; de-clutch
EXTRAS	Ventilated motor with internal fan (IP2x); encoder to RoHS standard; 12V or 24V 2Nm failsafe holding brake		



	PM50-38GB12				PM50-50GB12				PM50-63GB12				Gearbox GB12			
	Power (W)	Speed (rpm)	Torque (Nm)		Power (W)	Speed (rpm)	Torque (Nm)		Power (W)	Speed (rpm)	Torque (Nm)		Ratio	Efficiency†	Momentary overload (Nm)	
			Delrin	Bronze			Delrin	Bronze			Delrin	Bronze			Delrin	Bronze
Continuous S1 duty (assuming 24V supply)	81	512	1.4	1.4	110	504	1.9	1.8	142	496	2.4	2.3	12.5	95%	68	79
	83	424	1.8	1.7	110	420	2.3	2.2	141	416	2.8	2.7	12.5	95%	68	79
	80	296	2.5	2.4	110	294	3.1	3	129	292	3.8	3.7	12.5	95%	68	79
	83	212	3.4	3.3	110	210	4.4	4.3	141	208	5.5	5.4	25	90%	73	82
	82	100	6.7	6.6	104	100	9.2	9.1	127	99	9.7	9.5	30	84%	56	76
	82	60	10.4	10.1	104	60	12.8	12.5	127	59	15.2	14.7	50	78%	72	81
	71	30	17.2	16.8	94	30	*22.6	*22.2	118	29	*28.1	27.4	60	76%	57	76
	63	20	*22.7	*22.1	89	20	*29.7	*29.3	115	21	*36.8	*35.9	75	74%	40	45
Intermittent duty S3 30% (assuming 24V supply)	133	512	2.4	2.3	110	504	3.1	3	220	496	3.8	3.7	12.5	95%	68	79
	131	424	2.8	2.6	110	420	3.6	3.4	217	416	4.4	4.3	12.5	95%	68	79
	124	296	3.8	3.7	110	294	4.8	4.7	198	292	5.8	5.7	12.5	95%	68	79
	131	212	5.3	5.1	110	210	7	6.8	217	208	8.6	8.2	25	90%	73	82
	131	100	10.2	9.9	104	100	12.6	12.3	195	99	*15.0	14.6	30	84%	56	76
	131	60	*19.0	18.6	104	60	21.1	20.7	195	59	*23.2	22.7	50	78%	72	81
	110	30	*26.9	26.1	94	30	*35.1	*34.3	182	29	*43.3	*42.1	60	76%	57	76
	97	20	*34.7	*33.9	89	20	*45.8	*45.0	178	21	-	-	75	74%	40	45



Notes: Designed to operate with PWM controllers.

Graphs are available showing the motor performance throughout the speed range.

The GB12 gearbox may be coupled with many of our other standard AC or DC motors.

For customers who require in excess of 5000 units per year we offer a totally bespoke design service to fit the application; at zero cost premium. This service enables customers to outline any number of mechanical, electrical, environmental or even aesthetic requirements in order to realise their preferred motor-gearbox solution.

To find out more please contact a member of our sales team on +44 (0)1202 512 575 or visit our website at www.parvalux.com for further information.

*Gearbox life may be less than 5000 hours. Contact us for application advice. † Maximum theoretical efficiency.

drawing for PM50-38 / PM50-50 / PM50-63 with GB12 gearbox

standard motor-gearbox configured and customised for your application

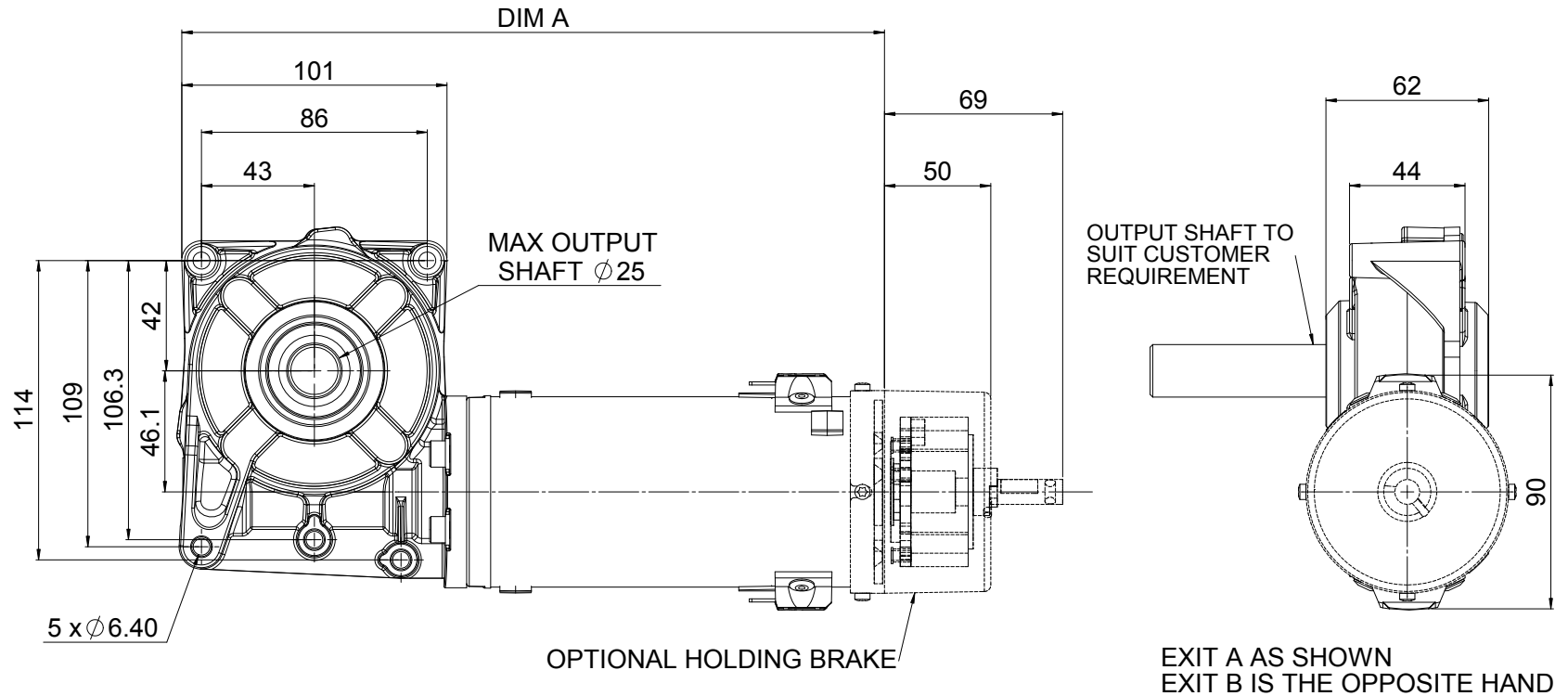

Motor Type	Motor Weight	Gearbox Weight with Delrin	Gearbox Weight with bronze	DIM A	
				Totally Enclosed	Ventilated
PM50-38	1.9 kg	1.1 kg	1.5 kg	239	252
PM50-50	2.0kg	1.1 kg	1.5 kg	251	264
PM50-63	2.1kg	1.1 kg	1.5 kg	264	277

All dimensions are in mm
Many of our drawings are available in
3D format. Please contact us with your
requirements



ERMEC, S.L. BARCELONA
C/ Francesc Teixidó, 22
E-08918 Badalona
(Spain)

Tel.: (+34) 902 450 160
Fax: (+34) 902 433 088
info@ermec.com
www.ermec.com

ERMEC, S.L. MADRID
C/ Sagasta, 8, 1ª planta
E-28004 Madrid
(Spain)

PORTUGAL
portugal@ermec.com
BILBAO
bilbao@ermec.com

For customers who require in excess of 5000 units per year we offer a totally bespoke design service to fit the application; at zero cost premium. This service enables customers to outline any number of mechanical, electrical, environmental or even aesthetic requirements in order to realise their preferred motor-gearbox solution. To find out more please contact a member of our sales team on +44 (0)1202 512 575 or visit our website at www.parvalux.com for further information.

PM63-50 / PM63-75 / PM63-100 permanent magnet DC motor

standard motor configured and customised for your application

MOTOR	Permanent magnet DC
SPEED	1500 - 8000 rpm
PROTECTION	IP44 - IP66
POWER	up to 900 Watts
VOLTAGE	12 - 240V DC
INSULATION	Class F
CONSTRUCTION	Ferrite magnets; aluminium end castings; single piece steel body; replaceable carbon brushes; spade connectors; maximum shaft diameter 12mm
EXTRAS	Ventilated motor with internal fan (IP2x); encoder to RoHS standard; 12V or 24V 2Nm failsafe holding brake; dedicated cable harness; shaft at both ends



	PM63-50			PM63-75			PM63-100		
	Power (W)	Speed (rpm)	Torque (Nm)	Power (W)	Speed (rpm)	Torque (Nm)	Power (W)	Speed (rpm)	Torque (Nm)
Continuous S1 duty (assuming 24V supply)	209	6450	0.29	247	6450	0.29	270	6450	0.4
	209	5475	0.37	247	5475	0.37	270	4750	0.54
	219	3785	0.55	257	3785	0.55	275	3750	0.7
	219	2995	0.7	257	2995	0.7	275	3060	0.86
	209	1820	1.05	247	1820	1.05	270	1800	1.43
	209	1520	1.14	247	1520	1.14	270	1575	1.64
Intermittent duty S3 30% (assuming 24V supply)	318	6250	0.48	356	6250	0.48	380	6300	0.58
	318	5250	0.58	356	5250	0.58	380	4600	0.79
	328	3600	0.87	366	3600	0.87	385	3650	1.01
	328	3100	1.01	366	3100	1.01	385	2940	1.25
	318	2000	1.52	356	2000	1.52	375	1740	2.06
	309	1500	1.97	356	1500	1.97	375	1425	2.51



ISO 9001:2000 Certificate No. FM548688

Notes: Designed to operate with PWM controllers.

Graphs are available showing the motor performance throughout the speed range.

This motor may be coupled with many of our standard worm, spur and planetary gearboxes.

For customers who require in excess of 5000 units per year we offer a totally bespoke design service to fit the application; at zero cost premium. This service enables customers to outline any number of mechanical, electrical, environmental or even aesthetic requirements in order to realise their preferred motor-gearbox solution.

To find out more please contact a member of our sales team on +44 (0)1202 512 575 or visit our website at www.parvalux.com for further information.

ERMEC
www.ermec.com
ERMEC, S.L. BARCELONA
C/ Francesc Teixidó, 22
E-08918 Badalona
(Spain)

Tel.: (+34) 902 450 160
Fax: (+34) 902 433 088
info@ermec.com
www.ermec.com

ERMEC, S.L. MADRID
C/ Sagasta, 8, 1ª planta
E-28004 Madrid
(Spain)

PORTUGAL
portugal@ermec.com
BILBAO
bilbao@ermec.com

PARVALUX

drawing for PM63-50 / PM63-75 / PM63-100 permanent magnet DC motor

standard motor configured and customised for your application

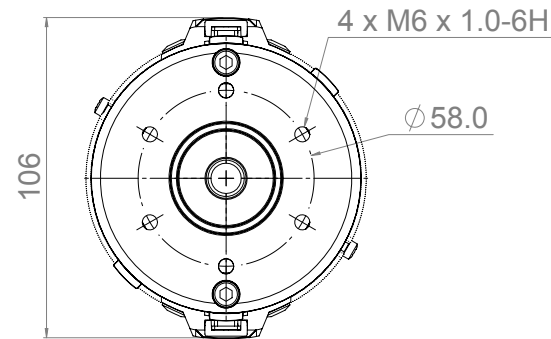

MAX OUTPUT SHAFT
Ø 11.8

OUTPUT SHAFT TO
SUIT CUSTOMER
REQUIREMENTS

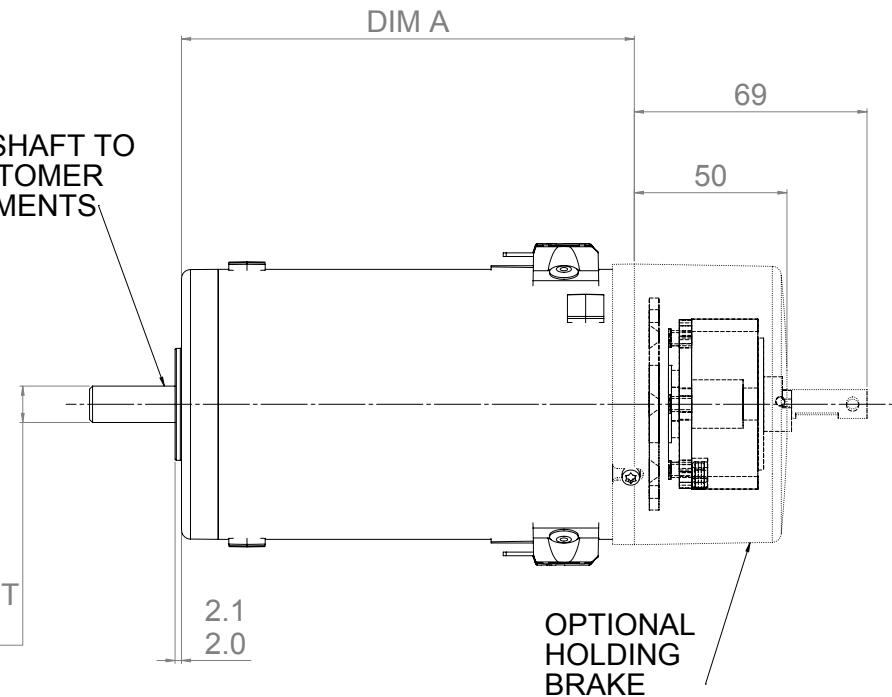

MOTOR BODY DIAMETER 90mm

Motor Type	Motor Weight	DIM A (mm)	
		Totally Enclosed	Ventilated
PM63-50	3.0 kg	150	163
PM63-75	4.0 kg	175	188
PM63-100	4.2 kg	200	213

All dimensions are in mm
Many of our drawings are available in
3D format. Please contact us with your
requirements



ERMEC, S.L. BARCELONA
C/ Francesc Teixidó, 22
E-08918 Badalona
(Spain)

Tel.: (+34) 902 450 160
Fax: (+34) 902 433 088
info@ermec.com
www.ermec.com

ERMEC, S.L. MADRID
C/ Sagasta, 8, 1ª planta
E-28004 Madrid
(Spain)

PORTUGAL
portugal@ermec.com
BILBAO
bilbao@ermec.com

For customers who require in excess of 5000 units per year we offer a totally bespoke design service to fit the application; at zero cost premium. This service enables customers to outline any number of mechanical, electrical, environmental or even aesthetic requirements in order to realise their preferred motor-gearbox solution. To find out more please contact a member of our sales team on +44 (0)1202 512 575 or visit our website at www.parvalux.com for further information.

PM63-50 / PM63-75 / PM63-100 with GB4 gearbox

standard motor configured and customised for your application

MOTOR	Permanent magnet DC	GEARBOX	Worm and wheel
SPEED	1500 - 8000 rpm	RATIOS	12.5:1, 25:1, 30:1, 50:1, 60:1, 75:1
PROTECTION	up to IP66	EFFICIENCY	up to 95%
POWER	up to 900 Watts	MATERIALS	Delrin or phosphor bronze
VOLTAGE	12 - 240V DC	SHAFT	single or double up to 20mm diameter
INSULATION	Class F	CONSTRUCTION	Steel worm shaft; CNC machined aluminium housing; sealed for life; cushioned 3-piece coupling; steel output shaft with 2 ball-bearings
CONSTRUCTION	Ferrite magnets; aluminium end castings; single piece steel body; replaceable carbon brushes; spade connectors	OPTIONS	Stainless steel shaft; black finish; dog clutch
EXTRAS	Ventilated motor with internal fan (IP2x); encoder to RoHS standard; 12V or 24V 2Nm failsafe holding brake		



	PM63-50GB4				PM63-75GB4				RE63-100GB4				Gearbox GB4			
	Power (W)	Speed (rpm)	Torque (Nm)		Power (W)	Speed (rpm)	Torque (Nm)		Power (W)	Speed (rpm)	Torque (Nm)		Ratio	Efficiency†	Momentary overload (Nm)	
			Delrin	Bronze			Delrin	Bronze			Delrin	Bronze			Delrin	Bronze
Continuous S1 duty (assuming 24V supply)	200	516	3.5	3.4	247	560	4.0	3.9	270	515	4.8	4.6	12.5	95%	68	79
	200	438	4.3	4.2	247	424	5.3	5.1	270	380	6.4	6.2	12.5	95%	68	79
	218	303	6.4	6.2	256	334	6.9	6.7	275	300	8.2	8.0	12.5	95%	68	79
	200	219	8.3	8.0	247	212	10.0	9.8	270	190	12.2	11.9	25	90%	73	82
	218	100	18.3*	17.8	256	93	22.9	22.3	275	103	24.2*	23.6	30	84%	56	76
	218	50	33.3*	32.5*	256	47	41.5*	39.4*	275	51	40.7*	39.6*	50	78%	72	81
	200	30	47.7*	46.5*	247	33	53.3*	50.6*	270	30	65.5*	63.8*	60	76%	57	76
	200	20	60.0*	58.3*	247	22	76.3*	74.3*	270	21	86.2*	81.0*	75	74%	40	45
Intermittent duty S3 30% (assuming 24V supply)	318	500	5.8	5.6	356	544	5.9	5.8	380	504	6.8	6.6	12.5	95%	68	79
	318	420	6.8	6.6	356	408	7.8	7.7	380	368	9.3	9.0	12.5	95%	68	79
	328	288	10.1	10.0	365	316	10.3	9.8	385	292	11.8	11.5	12.5	95%	68	79
	318	210	13.0	12.6	356	204	15.0*	14.6*	380	184	17.8*	17.3	25	90%	73	82
	328	103	26.3*	25.6*	365	90	33.9*	33.1*	385	98	32.7*	31.8*	30	84%	56	76
	328	52	47.7*	46.5*	365	45	61.6*	60.1*	385	49	59.4*	57.9*	50	78%	72	81
	318	33	-	67.5*	356	32	-	78.9*	375	29	-	-	60	76%	57	76
	308	20	-	-	356	19	-	106.4*	375	19	-	-	75	74%	40	45



Notes: Designed to operate with PWM controllers.

Graphs are available showing the motor performance throughout the speed range.

The GB4 gearbox is available as an MRO product; for new applications we recommend the GB12 gearbox instead, which offers improved performance with similar dimensions.

For customers who require in excess of 5000 units per year we offer a totally bespoke design service to fit the application; at zero cost premium. This service enables customers to outline any number of mechanical, electrical, environmental or even aesthetic requirements in order to realise their preferred motor-gearbox solution.

To find out more please contact a member of our sales team on +44 (0)1202 512 575 or visit our website at www.parvalux.com for further information.

*Gearbox life may be less than 5000 hours. Contact us for application advice. † Maximum theoretical efficiency.

PM63-50 / PM63-75 / PM63-100 with GB4 gearbox

standard motor configured and customised for your application

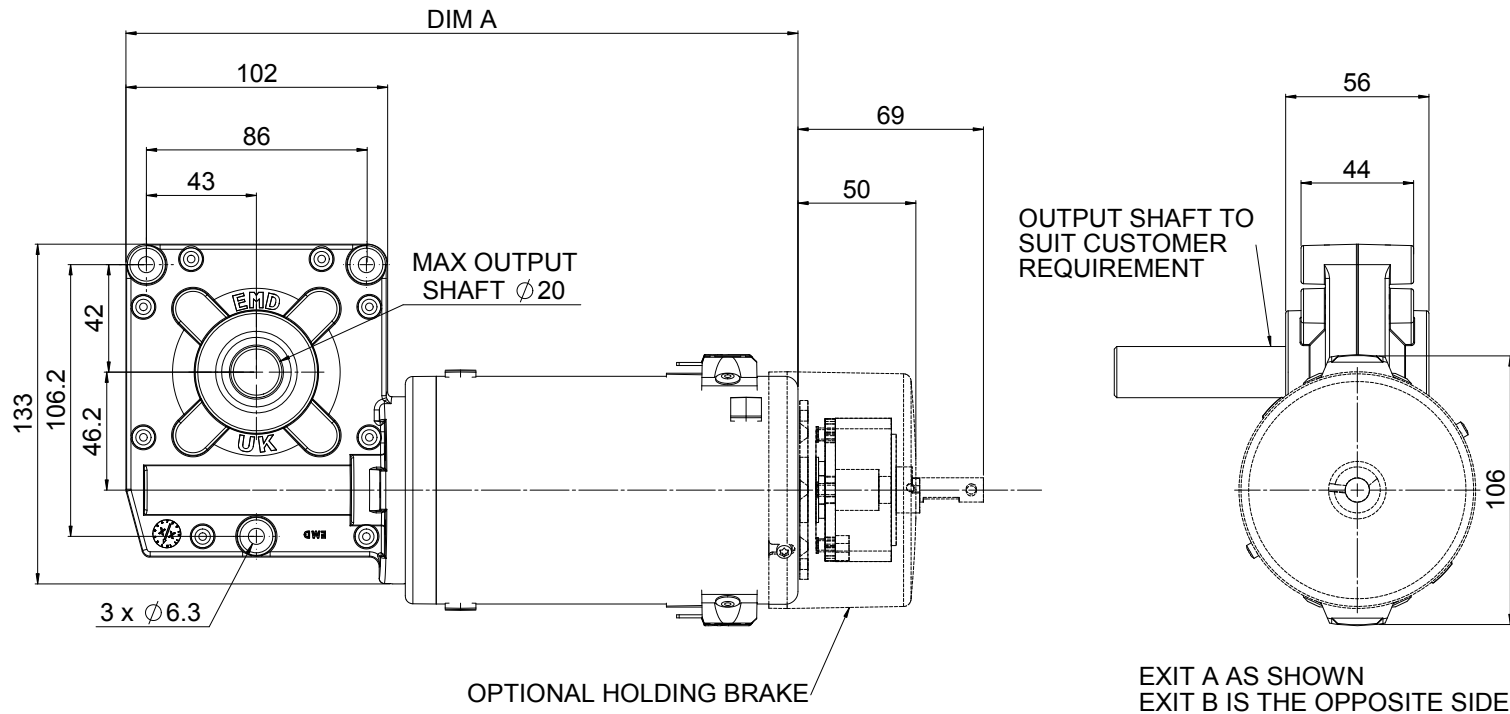

Motor Type	Motor Weight	Gearbox Weight with Delrin	Gearbox Weight with bronze	DIM A	
				Totally Enclosed	Ventilated
PM63-50	3.0 kg	1.0 kg	1.4 kg	264	277
PM63-75	3.8 kg	1.0 kg	1.4 kg	289	302
PM63-100	4.6 kg	1.0 kg	1.4 kg	314	327

All dimensions are in mm
Many of our drawings are available in 3D format. Please contact us with your requirements



ERMEC, S.L. BARCELONA
C/ Francesc Teixidó, 22
E-08918 Badalona
(Spain)

Tel.: (+34) 902 450 160
Fax: (+34) 902 433 088
info@ermec.com
www.ermec.com

ERMEC, S.L. MADRID
C/ Sagasta, 8, 1ª planta
E-28004 Madrid
(Spain)

PORTUGAL
portugal@ermec.com
BILBAO
bilbao@ermec.com

For customers who require in excess of 5000 units per year we offer a totally bespoke design service to fit the application; at zero cost premium. This service enables customers to outline any number of mechanical, electrical, environmental or even aesthetic requirements in order to realise their preferred motor-gearbox solution. To find out more please contact a member of our sales team on +44 (0)1202 512 575 or visit our website at www.parvalux.com for further information.

PM63-50 / PM63-75 / PM63-100 with GB9 gearbox

standard motor-gearbox configured and customised for your application

MOTOR	Permanent magnet DC	GEARBOX	Worm and wheel
SPEED	1500 - 8000 rpm	RATIOS	12.5:1, 25:1, 30:1, 60:1, 75:1
PROTECTION	up to IP66	EFFICIENCY	up to 95%
POWER	up to 900 Watts	MATERIALS	Delrin or phosphor bronze
VOLTAGE	12 - 240V DC	SHAFT	single or double up to 25mm diameter
INSULATION	Class F	CONSTRUCTION	Steel worm shaft; CNC machined aluminium housing; sealed for life - maintenance free; cushioned 1-piece coupling; steel output shaft with 2 ball-bearings
CONSTRUCTION	Ferrite magnets; aluminium end castings; single piece steel body; replaceable carbon brushes; spade connectors	OPTIONS	Stainless steel shaft; black finish; dog clutch
EXTRAS	Ventilated motor with internal fan (IP2x); encoder to RoHS standard; 12V or 24V 2Nm failsafe holding brake		

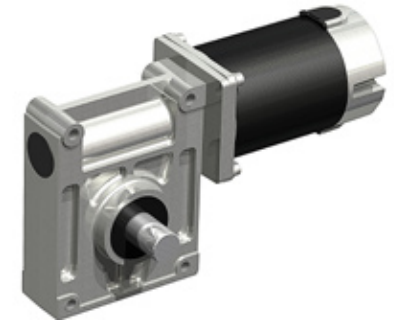

	PM63-50GB9				PM63-75GB9				PM63-100GB9				Gearbox GB9			
	Power (W)	Speed (rpm)	Torque (Nm)		Power (W)	Speed (rpm)	Torque (Nm)		Power (W)	Speed (rpm)	Torque (Nm)		Ratio	Efficiency†	Momentary overload (Nm)	
			Delrin	Bronze			Delrin	Bronze			Delrin	Bronze			Delrin	Bronze
Continuous S1 duty (assuming 24V supply)	200	516	3.5	3.4	247	560	4	3.9	270	515	4.8	4.6	12.5	95%	171	359
	200	438	4.3	4.2	247	424	5.3	5.1	270	380	6.4	6.2	12.5	95%	171	359
	218	303	6.4	6.2	256	334	6.9	6.7	275	300	8.2	8	12.5	94%	171	359
	200	219	8.3	8	247	212	10	9.8	270	190	12.2	11.9	25	90%	192	359
	218	100	*18.3	17.8	256	93	22.9	*22.3	275	103	*24.2	23.6	30	87%	145	160
	218	50	*33.3	*32.5	256	47	*41.5	*39.4	275	51	*40.7	*39.6	60	79%	148	316
	200	30	*47.7	*46.5	247	33	*53.3	*50.6	270	30	*65.5	*63.8	60	76%	104	316
	200	20	*60	*58.3	247	22	*76.3	*74.3	270	21	*86.2	*81	75	70%	104	266
Intermittent duty S3 30% (assuming 24V supply)	318	500	5.8	5.6	356	544	5.9	5.8	380	504	6.8	6.6	12.5	95%	171	359
	318	420	6.8	6.6	356	408	7.8	7.7	380	368	9.3	9	12.5	95%	171	359
	328	288	10.1	10	365	316	10.3	9.8	385	292	11.8	11.5	12.5	94%	171	359
	318	210	13	12.6	356	204	*15	*14.6	380	184	*17.8	17.3	25	90%	192	359
	328	103	*26.3	*25.6	365	90	*33.9	*33.1	385	98	*32.7	*31.8	30	87%	145	160
	328	52	*47.7	*46.5	365	45	*61.6	*60.1	385	49	*59.4	*57.9	60	79%	148	316
	318	33	*69.2	*67.5	356	32	*80.9	*78.9	375	29	*94	*91.6	60	76%	104	316
	308	20	*103.2	*100.7	356	19	-	*106.4	375	19	-	*128	75	70%	104	266



Notes: Designed to operate with PWM controllers.

Graphs are available showing the motor performance throughout the speed range.

The GB9 gearbox may be coupled with many of our other standard AC or DC motors.

For customers who require in excess of 5000 units per year we offer a totally bespoke design service to fit the application; at zero cost premium. This service enables customers to outline any number of mechanical, electrical, environmental or even aesthetic requirements in order to realise their preferred motor-gearbox solution.

To find out more please contact a member of our sales team on +44 (0)1202 512 575 or visit our website at www.parvalux.com for further information.

*Gearbox life may be less than 5000 hours. Contact us for application advice. † Maximum theoretical efficiency.

drawing for PM63-50 / PM63-75 / PM63-100 with GB9 gearbox

standard motor-gearbox configured and customised for your application

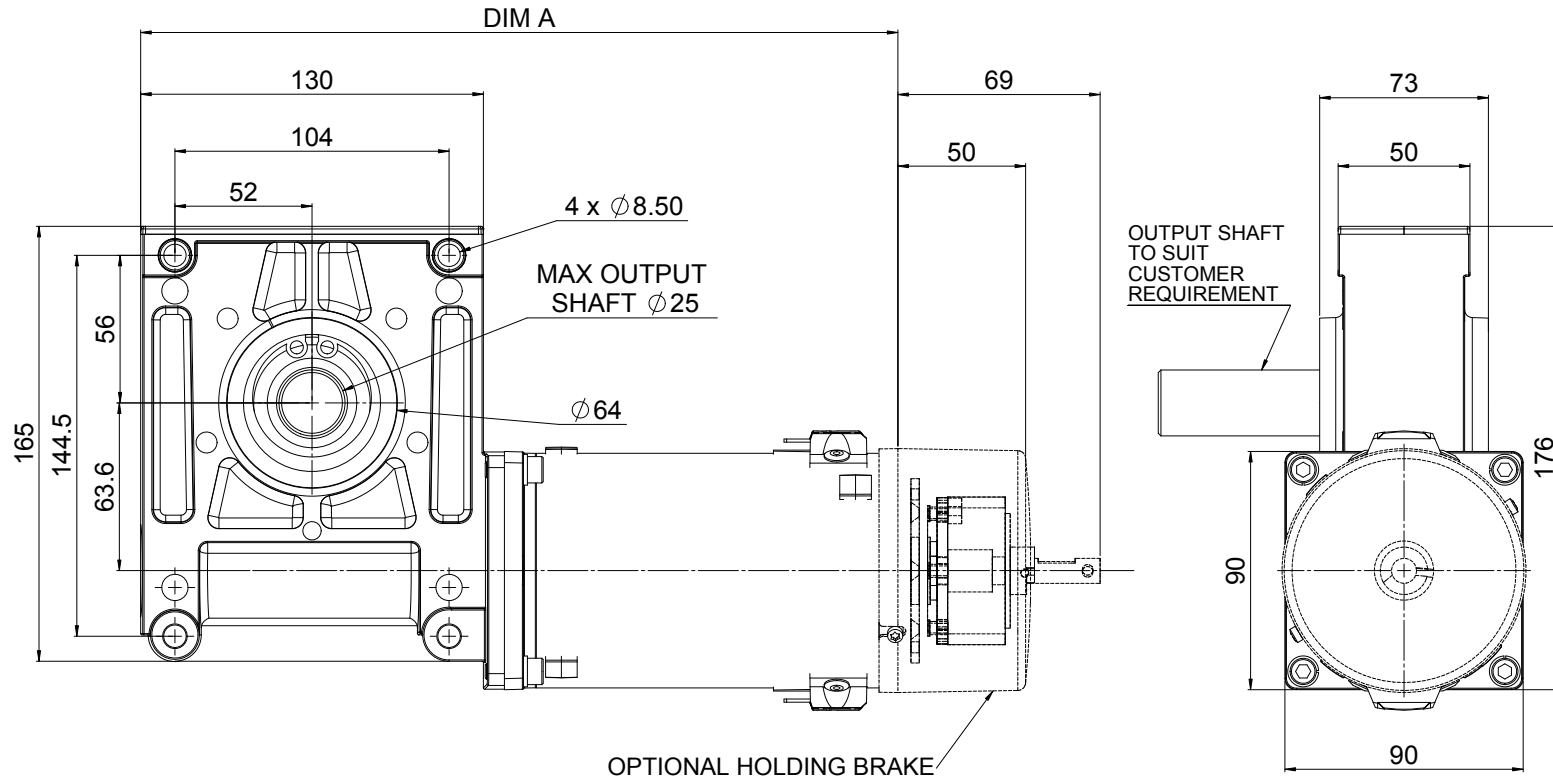

OUTPUT SHAFT TO SUIT CUSTOMER REQUIREMENT

OPTIONAL HOLDING BRAKE

EXIT A AS SHOWN
EXIT B IS THE
OPPOSITE HAND

All dimensions are in mm
Many of our drawings are available in 3D format. Please contact us with your requirements

Motor Type	Motor Weight	Gearbox Weight with Delrin	Gearbox Weight with bronze	DIM A	
				Totally Enclosed	Ventilated
PM63-50	3.0 kg	1.1 kg	1.5 kg	290	303
PM63-75	4.0 kg	1.1 kg	1.5 kg	315	328
PM63-100	4.0 kg	1.1 kg	1.5 kg	340	353



ERMEC, S.L. BARCELONA
C/ Francesc Teixidó, 22
E-08918 Badalona
(Spain)

Tel.: (+34) 902 450 160
Fax: (+34) 902 433 088
info@ermec.com
www.ermec.com

ERMEC, S.L. MADRID
C/ Sagasta, 8, 1ª planta
E-28004 Madrid
(Spain)

PORTUGAL
portugal@ermec.com
BILBAO
bilbao@ermec.com

For customers who require in excess of 5000 units per year we offer a totally bespoke design service to fit the application; at zero cost premium. This service enables customers to outline any number of mechanical, electrical, environmental or even aesthetic requirements in order to realise their preferred motor-gearbox solution. To find out more please contact a member of our sales team on +44 (0)1202 512 575 or visit our website at www.parvalux.com for further information.

PM63-50 / PM63-75 / PM63-100 with GB12 gearbox

standard motor-gearbox configured and customised for your application

MOTOR	Permanent magnet DC	GEARBOX	Worm and wheel
SPEED	1500 - 8000 rpm	RATIOS	12.5:1, 25:1, 30:1, 50:1, 60:1, 75:1
PROTECTION	IP44 - IP66	EFFICIENCY	up to 95%
POWER	up to 900 Watts	MATERIALS	Delrin or phosphor bronze
VOLTAGE	12 - 240V DC	SHAFT	single or double up to 25mm diameter
INSULATION	Class F	CONSTRUCTION	Steel worm shaft; CNC machined aluminium housing; sealed for life - maintenance free; cushioned 1-piece coupling; steel output shaft with 2 ball-bearings
CONSTRUCTION	Ferrite magnets; aluminium end castings; single piece steel body; replaceable carbon brushes; spade connectors	OPTIONS	Stainless steel shaft; black finish; de-clutch
EXTRAS	Ventilated motor with internal fan (IP2x); encoder to RoHS standard; 12V or 24V 2Nm failsafe holding brake		



	PM63-50GB12				PM63-75GB12				PM63-100GB12				Gearbox GB12			
	Power (W)	Speed (rpm)	Torque (Nm)		Power (W)	Speed (rpm)	Torque (Nm)		Power (W)	Speed (rpm)	Torque (Nm)		Ratio	Efficiency†	Momentary overload (Nm)	
			Delrin	Bronze			Delrin	Bronze			Delrin	Bronze			Delrin	Bronze
Continuous S1 duty (assuming 24V supply)	200	516	3.5	3.4	247	560	4	3.9	270	515	4.8	4.6	12.5	95%	68	79
	200	438	4.3	4.2	247	424	5.3	5.1	270	380	6.4	6.2	12.5	95%	68	79
	218	303	6.4	6.2	256	334	6.9	6.7	275	300	8.2	8	12.5	95%	68	79
	200	219	8.3	8	247	212	10	9.8	270	190	12.2	11.9	25	90%	73	82
	218	100	*18.3	17.8	256	93	22.9	*22.3	275	103	*24.2	23.6	30	84%	56	76
	218	50	*33.3	*32.5	256	47	*41.5	*39.4	275	51	*40.7	*39.6	60	78%	72	81
	200	30	*47.7	*46.5	247	33	*53.3	*50.6	270	30	*65.5	*63.8	60	76%	57	76
	200	20	*60	*58.3	247	22	*76.3	*74.3	270	21	*86.2	*81	75	74%	40	45
Intermittent duty S3 30% (assuming 24V supply)	318	500	5.8	5.6	356	544	5.9	5.8	380	504	6.8	6.6	12.5	95%	68	79
	318	420	6.8	6.6	356	408	7.8	7.7	380	368	9.3	9	12.5	95%	68	79
	328	288	10.1	10	365	316	10.3	9.8	385	292	11.8	11.5	12.5	95%	68	79
	318	210	13	12.6	356	204	*15.0	*14.6	380	184	*17.8	17.3	25	90%	73	82
	328	103	*26.3	*25.6	365	90	*33.9	*33.1	385	98	*32.7	*31.8	30	84%	56	76
	328	52	*47.7	*46.5	365	45	*61.6	*60.1	385	49	*59.4	*57.9	60	78%	72	81
	318	33	*69.2	*67.5	356	32	*80.9	*78.9	375	29	*94	*91.6	60	76%	57	76
	308	20	*103.2	*100.7	356	19	*122.6	*106.4	375	19	*132	*128	75	74%	40	45



Notes: Designed to operate with PWM controllers.

Graphs are available showing the motor performance throughout the speed range.

The GB12 gearbox may be coupled with many of our other standard AC or DC motors.

For customers who require in excess of 5000 units per year we offer a totally bespoke design service to fit the application; at zero cost premium. This service enables customers to outline any number of mechanical, electrical, environmental or even aesthetic requirements in order to realise their preferred motor-gearbox solution.

To find out more please contact a member of our sales team on +44 (0)1202 512 575 or visit our website at www.parvalux.com for further information.

*Gearbox life may be less than 5000 hours. Contact us for application advice. † Maximum theoretical efficiency.

drawing for PM63-50 / PM63-75 / PM63-100 with GB12 gearbox

standard motor-gearbox configured and customised for your application

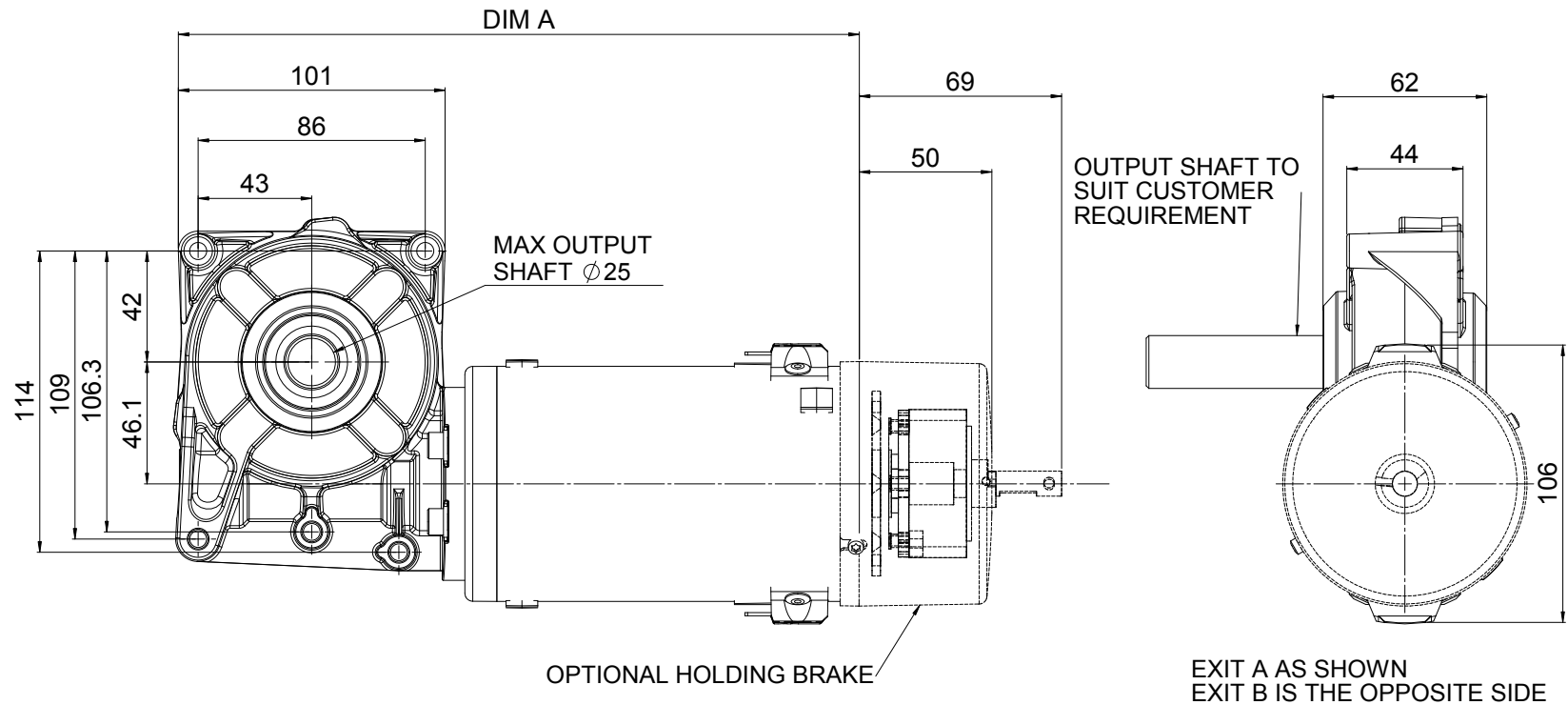

Motor Type	Motor Weight	Gearbox Weight with Delrin	Gearbox Weight with bronze	DIM A	
				Totally Enclosed	Ventilated
PM63-50	3.0 kg	1.1 kg	1.5 kg	263	277
PM63-75	4.0 kg	1.1 kg	1.5 kg	288	301
PM63-100	4.0 kg	1.1 kg	1.5 kg	313	326

Motor body diameter 90mm

All dimensions are in mm
Many of our drawings are available in 3D format. Please contact us with your requirements



ERMEC, S.L. BARCELONA
C/ Francesc Teixidó, 22
E-08918 Badalona
(Spain)

Tel.: (+34) 902 450 160
Fax: (+34) 902 433 088
info@ermec.com
www.ermec.com

ERMEC, S.L. MADRID
C/ Sagasta, 8, 1ª planta
E-28004 Madrid
(Spain)

PORTUGAL
portugal@ermec.com
BILBAO
bilbao@ermec.com

For customers who require in excess of 5000 units per year we offer a totally bespoke design service to fit the application; at zero cost premium. This service enables customers to outline any number of mechanical, electrical, environmental or even aesthetic requirements in order to realise their preferred motor-gearbox solution. To find out more please contact a member of our sales team on +44 (0)1202 512 575 or visit our website at www.parvalux.com for further information.

PM90-150 / PM90-180 / RE90-146 (rare earth) permanent magnet DC motor

standard motor configured and customised for your application

MOTOR	Permanent magnet DC
SPEED	1500 - 8000 rpm
PROTECTION	IP44 - IP66
POWER	up to 900 Watts
VOLTAGE	12 - 240V DC
INSULATION	Class F
CONSTRUCTION	Ferrite or rare-earth Neodymium (NdFeB) magnets; aluminium end castings; single piece steel body; replaceable carbon brushes; spade connectors; maximum shaft diameter 12mm
EXTRAS	Ventilated motor with internal fan (IP2x); encoder to RoHS standard; 12V or 24V 2Nm failsafe holding brake; dedicated cable harness; shaft at both ends



	PM90-150			PM90-180			RE90-146		
	Power (W)	Speed (rpm)	Torque (Nm)	Power (W)	Speed (rpm)	Torque (Nm)	Power (W)	Speed (rpm)	Torque (Nm)
Continuous S1 duty (assuming 24V supply)	220	6450	0.3	260	6450	0.38	230	6800	0.32
	220	5475	0.38	260	5475	0.45	230	5120	0.42
	230	3785	0.58	270	3785	0.68	235	3750	0.59
	230	2995	0.74	270	2995	0.86	235	3100	0.72
	220	1820	1.1	260	1820	1.3	235	1900	1.18
	220	1520	1.2	260	1520	1.5	235	1550	1.44
Intermittent duty S3 30% (assuming 24V supply)	335	6250	0.51	375	6250	0.57	345	6500	0.5
	335	5250	0.6	375	5250	0.68	345	4975	0.66
	345	3600	0.91	385	3600	0.98	350	3600	0.89
	345	3100	1.06	385	3100	1.18	350	3000	1.11
	335	2000	1.6	375	2000	1.85	350	1800	1.86
	325	1500	2.07	375	1500	2.25	350	1600	2.22



ISO 9001:2000 Certificate No. FM548688

Notes: Designed to operate with PWM controllers.

Graphs are available showing the motor performance throughout the speed range.

This motor may be coupled with many of our standard worm, spur and planetary gearboxes.

For customers who require in excess of 5000 units per year we offer a totally bespoke design service to fit the application; at zero cost premium. This service enables customers to outline any number of mechanical, electrical, environmental or even aesthetic requirements in order to realise their preferred motor-gearbox solution.

To find out more please contact a member of our sales team on +44 (0)1202 512 575 or visit our website at www.parvalux.com for further information.



ERMEC, S.L. BARCELONA
C/ Francesc Teixidó, 22
E-08918 Badalona
(Spain)

Tel.: (+34) 902 450 160
Fax: (+34) 902 433 088
info@ermec.com
www.ermec.com

ERMEC, S.L. MADRID
C/ Sagasta, 8, 1ª planta
E-28004 Madrid
(Spain)

PORTUGAL
portugal@ermec.com
BILBAO
bilbao@ermec.com

PARVALUX

drawing for PM90-150 / PM90-180 / RE90-146 (rare earth) permanent magnet DC motor

standard motor configured and customised for your application

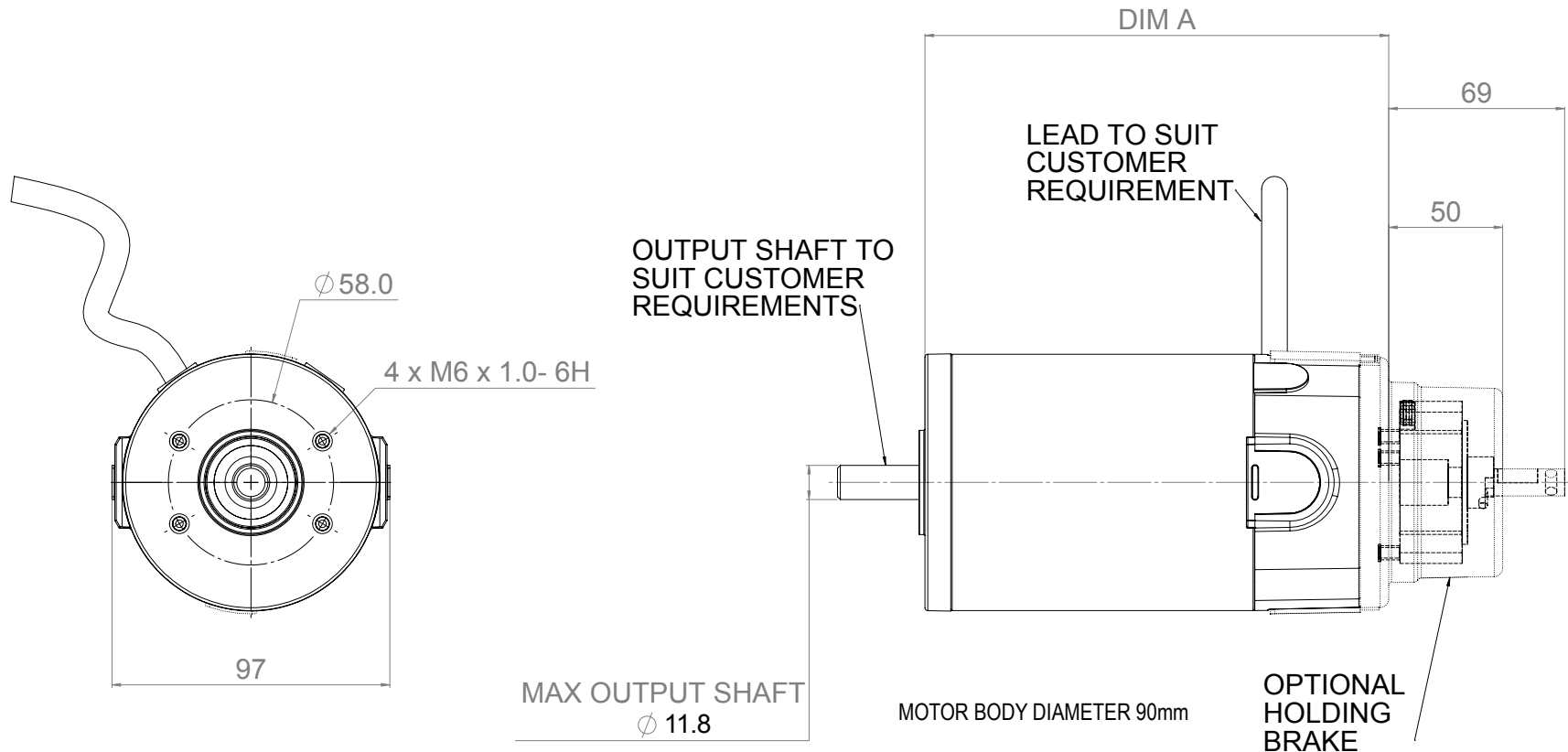

Motor Type	Motor Weight	DIMA (mm)	
		Totally Enclosed	Ventilated
PM90-150	3.0 kg	150	163
PM90-180	4.0 kg	180	193
RE90-146	4.0 kg	146	159

All dimensions are in mm

Many of our drawings are available in 3D format. Please contact us with your requirements



ERMEC, S.L. BARCELONA
C/ Francesc Teixidó, 22
E-08918 Badalona
(Spain)

Tel.: (+34) 902 450 160
Fax: (+34) 902 433 088
info@ermec.com
www.ermec.com

ERMEC, S.L. MADRID
C/ Sagasta, 8, 1ª planta
E-28004 Madrid
(Spain)

PORTUGAL
portugal@ermec.com
BILBAO
bilbao@ermec.com

For customers who require in excess of 5000 units per year we offer a totally bespoke design service to fit the application; at zero cost premium. This service enables customers to outline any number of mechanical, electrical, environmental or even aesthetic requirements in order to realise their preferred motor-gearbox solution. To find out more please contact a member of our sales team on +44 (0)1202 512 575 or visit our website at www.parvalux.com for further information.

PM90-150 / PM90-180 / RE90-146 (rare earth) with GB4 gearbox

standard motor configured and customised for your application

MOTOR	Permanent magnet DC	GEARBOX	Worm and wheel
SPEED	1500 - 8000 rpm	RATIOS	12.5:1, 25:1, 30:1, 50:1, 60:1, 75:1
PROTECTION	IP44 - IP66	EFFICIENCY	up to 95%
POWER	up to 900 Watts	MATERIALS	Delrin or phosphor bronze
VOLTAGE	12 - 240V DC	SHAFT	single or double up to 20mm diameter
INSULATION	Class F	CONSTRUCTION	Steel worm shaft; CNC machined aluminium housing; sealed for life; cushioned 3-piece coupling; steel output shaft with 2 ball-bearings
CONSTRUCTION	Ferrite or rare-earth Neodymium (NdFeB) magnets; aluminium end castings; single piece steel body; replaceable carbon brushes; 300mm flying leads	OPTIONS	Stainless steel shaft; black finish; dog clutch
EXTRAS	Ventilated motor with internal fan (IP2x); encoder to RoHS standard; 12V or 24V 2Nm failsafe holding brake; dedicated cable harness		



	PM90-150GB4				PM90-180GB4				RE90-146GB4				Gearbox GB4			
	Power (W)	Speed (rpm)	Torque (Nm)		Power (W)	Speed (rpm)	Torque (Nm)		Power (W)	Speed (rpm)	Torque (Nm)		Ratio	Efficiency†	Momentary overload (Nm)	
			Delrin	Bronze			Delrin	Bronze			Delrin	Bronze			Delrin	Bronze
Continuous S1 duty (assuming 24V supply)	210	516	3.7	3.6	230	560	4.2	4.1	230	544	3.8	3.7	12.5	95%	68	79
	220	438	4.6	4.5	230	424	5.6	5.4	230	410	5.1	5.0	12.5	95%	68	79
	230	303	6.8	6.6	235	334	7.3	7.1	235	300	7.0	6.8	12.5	95%	68	79
	220	219	8.8	8.5	230	212	10.6	10.3	230	205	9.7	9.4	25	90%	73	82
	230	100	19.3*	18.8	235	93	24.1	23.5*	235	103	18.9*	18.4	30	84%	56	76
	230	50	35.1*	34.2*	235	47	43.7*	42.6*	235	52	34.4*	33.5*	50	78%	72	81
	220	30	50.2*	49.0*	235	33	56.1*	54.7*	235	32	53.8*	52.5*	60	76%	57	76
	220	20	63.0*	61.4*	235	22	80.3*	78.3*	235	21	75.6*	73.7*	75	74%	40	45
Intermittent duty S3 30% (assuming 24V supply)	335	500	6.1	5.9	345	544	6.3	6.1	345	520	6.0	5.9	12.5	95%	68	79
	335	420	7.2	7.0	345	408	8.3	8.1	345	396	7.8	7.6	12.5	95%	68	79
	345	288	10.7	10.5	350	316	10.9	10.6	350	288	10.5	10.2	12.5	95%	68	79
	335	210	13.7	13.3	345	204	15.8*	15.4*	345	199	14.9*	14.5	25	90%	73	82
	345	103	27.7*	27.0*	350	90	35.7*	34.9*	350	100	29.0*	28.2*	30	84%	56	76
	345	52	50.2*	49.0*	350	45	64.9*	63.3*	350	50	52.6	51.3*	50	78%	72	81
	335	33	72.9*	71.1*	350	32	85.2*	83.1*	350	30	84.8*	82.7*	60	76%	57	76
	325	20	108.6*	106.0*	350	19	129.1*	112.0*	350	21	116.5*	113.6*	75	74%	40	45



Notes: Designed to operate with PWM controllers.

Graphs are available showing the motor performance throughout the speed range.

The GB4 gearbox is available as an MRO product; for new applications we recommend the GB12 gearbox instead, which offers improved performance with similar dimensions.

For customers who require in excess of 5000 units per year we offer a totally bespoke design service to fit the application; at zero cost premium. This service enables customers to outline any number of mechanical, electrical, environmental or even aesthetic requirements in order to realise their preferred motor-gearbox solution.

To find out more please contact a member of our sales team on +44 (0)1202 512 575 or visit our website at www.parvalux.com for further information.

*Gearbox life may be less than 5000 hours. Contact us for application advice. † Maximum theoretical efficiency.

PM90-150 / PM90-180 / RE90-146 (rare earth) with GB4 gearbox

standard motor configured and customised for your application

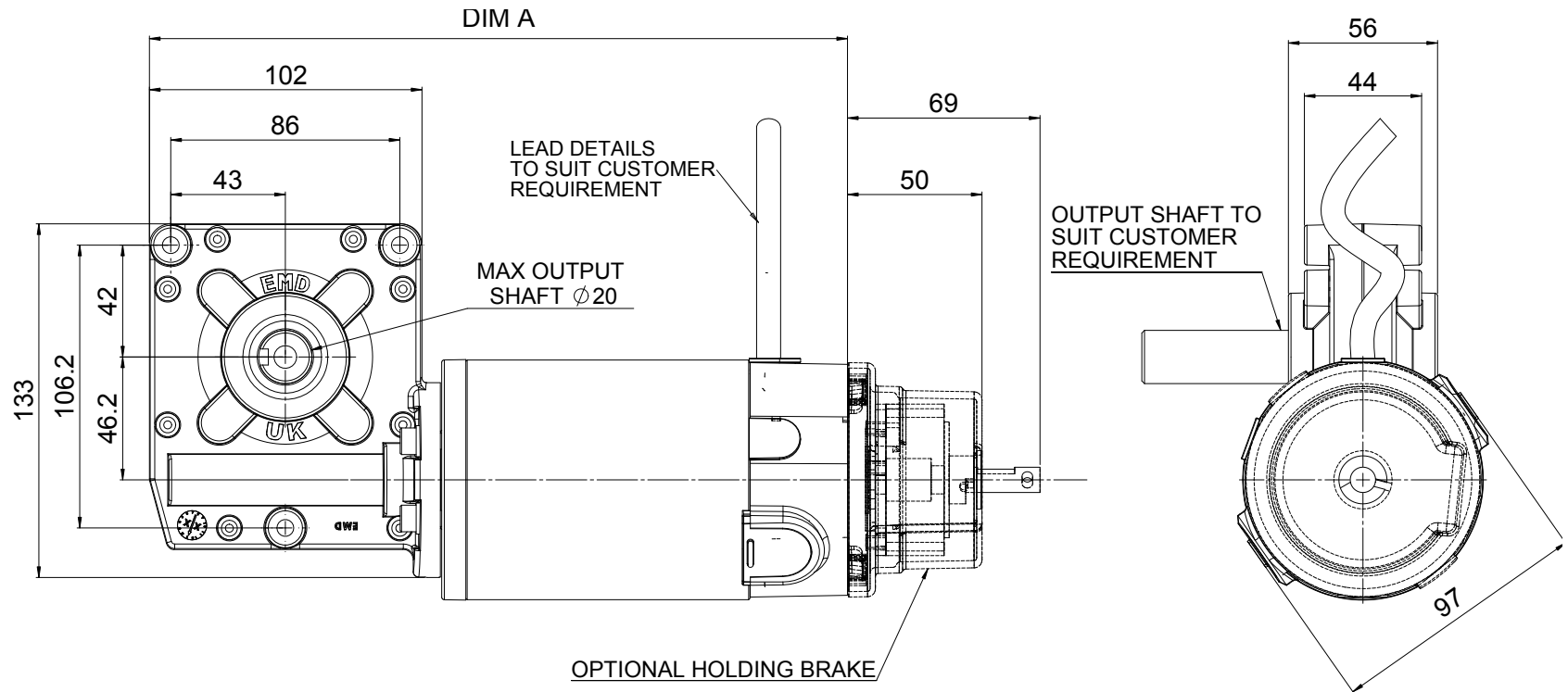

EXIT A AS SHOWN
EXIT B IS THE OPPOSITE HAND

Motor Type	Motor Weight	Gearbox Weight with Delrin	Gearbox Weight with bronze	DIM A	
				Totally Enclosed	Ventilated
PM90-150	3.0 kg	1.0kg	1.4 kg	264	277
PM90-180	4.0 kg	1.0kg	1.4 kg	294	307
RE90-146	4.0 kg	1.0kg	1.4 kg	260	273

All dimensions are in mm
Many of our drawings are available in
3D format. Please contact us with your
requirements

ERMEC ERMEC, S.L. BARCELONA
C/ Francesc Teixidó, 22
E-08918 Badalona
(Spain)

Tel.: (+34) 902 450 160
Fax: (+34) 902 433 088
info@ermec.com
www.ermec.com

ERMEC, S.L. MADRID
C/ Sagasta, 8, 1ª planta
E-28004 Madrid
(Spain)

PORTUGAL
portugal@ermec.com
BILBAO
bilbao@ermec.com

PM90-150 / PM90-180 / RE90-146 (rare earth) with GB9 gearbox

standard motor-gearbox configured and customised for your application

MOTOR	Permanent magnet DC	GEARBOX	Worm and wheel
SPEED	1500 - 8000 rpm	RATIOS	12.5:1, 25:1, 30:1, 60:1, 75:1
PROTECTION	IP44 - IP66	EFFICIENCY	up to 95%
POWER	up to 900 Watts	MATERIALS	Delrin or phosphor bronze
VOLTAGE	12 - 240V DC	SHAFT	single or double up to 25mm diameter
INSULATION	Class F	CONSTRUCTION	Steel worm shaft; CNC machined aluminium housing; sealed for life - maintenance free; cushioned 1-piece coupling; steel output shaft with 2 ball-bearings
CONSTRUCTION	Ferrite or rare-earth Neodymium (NdFeB) magnets; aluminium end castings; single piece steel body; replaceable carbon brushes; 300mm flying leads	OPTIONS	Stainless steel shaft; black finish; dog clutch
EXTRAS	Ventilated motor with internal fan (IP2x); encoder to RoHS standard; 12V or 24V 2Nm failsafe holding brake; dedicated cable harness		



	PM90-150GB9				PM90-180GB9				RE90-146GB9				Gearbox GB9			
	Power (W)	Speed (rpm)	Torque (Nm)		Power (W)	Speed (rpm)	Torque (Nm)		Power (W)	Speed (rpm)	Torque (Nm)		Ratio	Efficiency†	Momentary overload (Nm)	
			Delrin	Bronze			Delrin	Bronze			Delrin	Bronze			Delrin	Bronze
Continuous S1 duty (assuming 24V supply)	210	516	3.7	3.6	260	560	4.2	4.1	230	544	3.8	3.7	12.5	95%	171	359
	220	438	4.6	4.5	260	424	5.6	5.4	230	410	5.1	5	12.5	95%	171	359
	230	303	6.8	6.6	270	334	7.3	7.1	235	300	7	6.8	12.5	94%	171	359
	220	219	8.8	8.5	260	212	10.6	10.3	230	205	9.7	9.4	25	90%	192	359
	230	100	19.3	18.8	270	93	24.1	23.5	235	103	18.9	18.4	30	87%	145	160
	230	50	35.1	34.2	270	47	*43.7	42.6	235	52	34.4	33.5	60	79%	148	316
	220	30	50.2	49	260	33	56.1	54.7	235	32	53.8	52.5	60	76%	104	316
	220	20	*63.0	61.4	260	22	*80.3	78.3	235	21	*75.6	73.7	75	70%	104	266
Intermittent duty S3 30% (assuming 24V supply)	335	500	6.1	5.9	375	544	6.3	6.1	345	520	6	5.9	12.5	95%	171	359
	335	420	7.2	7	375	408	8.3	8.1	345	398	7.8	7.6	12.5	95%	171	359
	345	288	10.7	10.5	385	316	10.9	10.6	350	288	10.5	10.2	12.5	94%	171	359
	335	210	13.7	13.3	375	204	15.8	15.4	345	199	14.9	14.5	25	90%	192	359
	345	103	27.7	27	385	90	*35.7	34.9	350	100	29	28.2	30	87%	145	160
	345	52	*50.2	49	385	45	*64.9	63.3	350	50	*52.6	51.3	60	79%	148	316
	335	33	*72.9	71.1	375	32	*85.2	83.1	350	30	*84.8	82.7	60	76%	104	316
	325	20	-	106	375	19	-	112	350	21	-	*113.6	75	70%	104	266



Notes: Designed to operate with PWM controllers.

Graphs are available showing the motor performance throughout the speed range.

The GB9 gearbox may be coupled with many of our other standard AC or DC motors.

For customers who require in excess of 5000 units per year we offer a totally bespoke design service to fit the application; at zero cost premium. This service enables customers to outline any number of mechanical, electrical, environmental or even aesthetic requirements in order to realise their preferred motor-gearbox solution.

To find out more please contact a member of our sales team on +44 (0)1202 512 575 or visit our website at www.parvalux.com for further information.

*Gearbox life may be less than 5000 hours. Contact us for application advice. † Maximum theoretical efficiency.

drawing for PM90-150 / PM90-180 / RE90-146 (rare earth) with GB9 gearbox

standard motor-gearbox configured and customised for your application

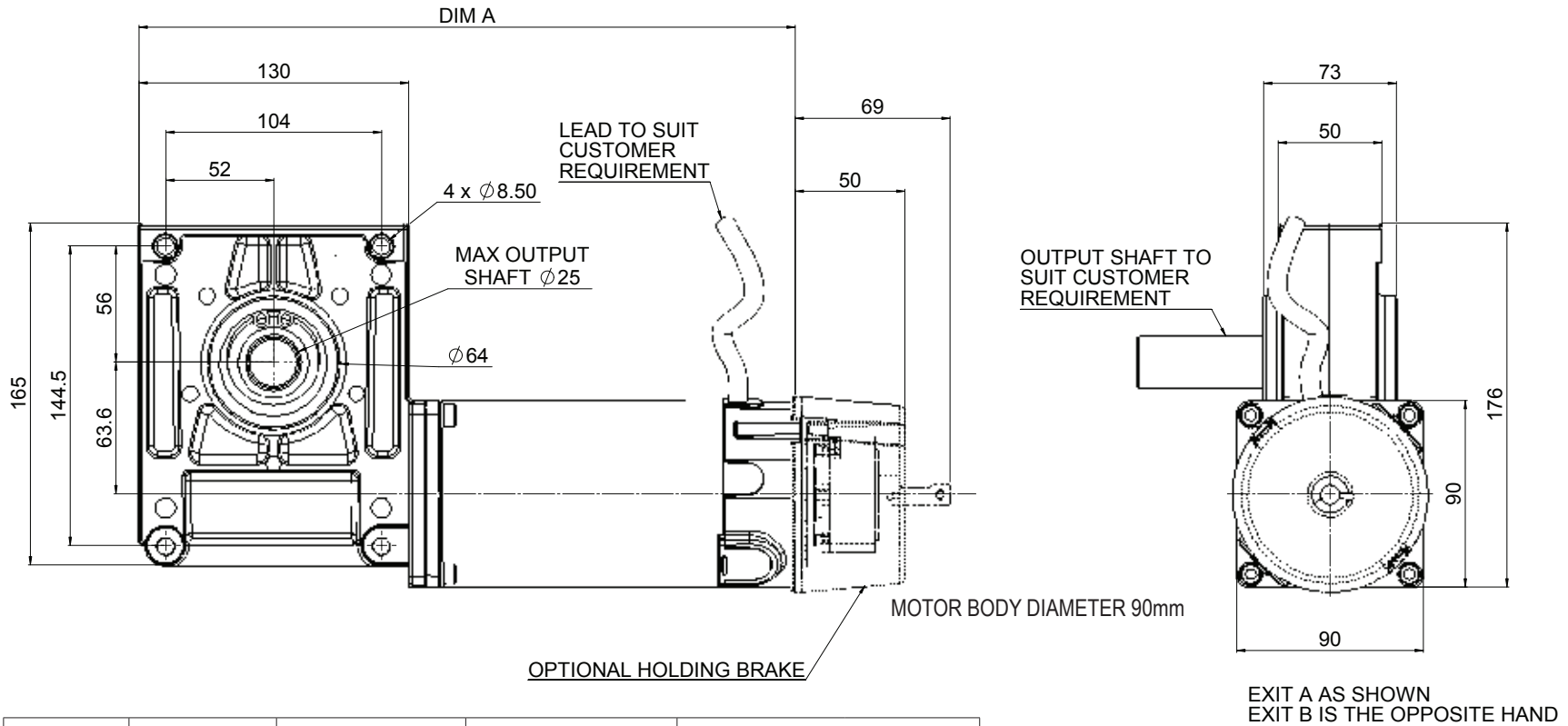

Motor Type	Motor Weight	Gearbox Weight with Delrin	Gearbox Weight with bronze	DIM A	
				Totally Enclosed	Ventilated
PM90-150	3.0 kg	2.3 kg	3.4 kg	290	303
PM90-180	4.0 kg	2.3 kg	3.4 kg	320	333
RE90-146	4.0 kg	2.3 kg	3.4 kg	286	299

All dimensions are in mm
 Many of our drawings are available in 3D format. Please contact us with your requirements



ERMEC, S.L. BARCELONA
 C/ Francesc Teixidó, 22
 E-08918 Badalona
 (Spain)

Tel.: (+34) 902 450 160
Fax: (+34) 902 433 088
info@ermec.com
www.ermec.com

ERMEC, S.L. MADRID
 C/ Sagasta, 8, 1ª planta
 E-28004 Madrid
 (Spain)

PORTUGAL
portugal@ermec.com
BILBAO
bilbao@ermec.com

For customers who require in excess of 5000 units per year we offer a totally bespoke design service to fit the application; at zero cost premium. This service enables customers to outline any number of mechanical, electrical, environmental or even aesthetic requirements in order to realise their preferred motor-gearbox solution. To find out more please contact a member of our sales team on +44 (0)1202 512 575 or visit our website at www.parvalux.com for further information.

PM90-150 / PM90-180 / RE90-146 (rare earth) with GB12 gearbox

standard motor-gearbox configured and customised for your application

MOTOR	Permanent magnet DC	GEARBOX	Worm and wheel
SPEED	1500 - 8000 rpm	RATIOS	12.5:1, 25:1, 30:1, 50:1, 60:1, 75:1
PROTECTION	IP44 - IP66	EFFICIENCY	up to 95%
POWER	up to 900 Watts	MATERIALS	Delrin or phosphor bronze
VOLTAGE	12 - 240V DC	SHAFT	single or double up to 25mm diameter
INSULATION	Class F	CONSTRUCTION	Steel worm shaft; CNC machined aluminium housing; sealed for life - maintenance free; cushioned 1-piece coupling; steel output shaft with 2 ball-bearings
CONSTRUCTION	Ferrite or rare-earth Neodymium (NdFeB) magnets; aluminium end castings; single piece steel body; replaceable carbon brushes; 300mm flying leads	OPTIONS	Stainless steel shaft; black finish; de-clutch
EXTRAS	Ventilated motor with internal fan (IP2x); Encoder to RoHS standard; 12V or 24V 2Nm failsafe holding brake; dedicated cable harness		



	PM90-150GB12				PM90-180GB12				RE90-146GB12				Gearbox GB12			
	Power (W)	Speed (rpm)	Torque (Nm)		Power (W)	Speed (rpm)	Torque (Nm)		Power (W)	Speed (rpm)	Torque (Nm)		Ratio	Efficiency†	Momentary overload (Nm)	
			Delrin	Bronze			Delrin	Bronze			Delrin	Bronze			Delrin	Bronze
Continuous S1 duty (assuming 24V supply)	210	516	3.7	3.6	260	560	4.2	4.1	230	544	3.8	3.7	12.5	95%	68	79
	220	438	4.6	4.5	260	424	5.6	5.4	230	410	5.1	5	12.5	95%	68	79
	230	303	6.8	6.6	270	334	7.3	7.1	235	300	7	6.8	12.5	95%	68	79
	220	219	8.8	8.5	260	212	10.6	10.3	230	205	9.7	9.4	25	90%	73	82
	230	100	*19.3	18.8	270	93	24.1	*23.5	235	103	*18.9	18.4	30	84%	56	76
	230	50	*35.1	*34.2	270	47	*43.7	*42.6	235	52	*34.4	*33.5	60	78%	72	81
	220	30	*50.2	*49.0	260	33	*56.1	*54.7	235	32	*53.8	*52.5	60	76%	57	76
	220	20	*63.0	*61.4	260	22	*80.3	*78.3	235	21	*75.6	*73.7	75	74%	40	45
Intermittent duty S3 30% (assuming 24V supply)	335	500	6.1	5.9	375	544	6.3	6.1	345	520	6	5.9	12.5	95%	68	79
	335	420	7.2	7	375	408	8.3	8.1	345	398	7.8	7.6	12.5	95%	68	79
	345	288	10.7	10.5	385	316	10.9	10.6	350	288	10.5	10.2	12.5	95%	68	79
	335	210	13.7	13.3	375	204	*15.8	*15.4	345	199	*14.9	14.5	25	90%	73	82
	345	103	*27.7	*27.0	385	90	*35.7	*34.9	350	100	*29.0	*28.2	30	84%	56	76
	345	52	*50.2	*49.0	385	45	*64.9	*63.3	350	50	*52.6	*51.3	60	78%	72	81
	335	33	*72.9	*71.1	375	32	*85.2	*83.1	350	30	*84.8	*82.7	60	76%	57	76
	325	20	*108.6	*106.0	375	19	*129.1	*112.0	350	21	*116.5	*113.6	75	74%	40	45



Notes: Designed to operate with PWM controllers.

Graphs are available showing the motor performance throughout the speed range.

The GB12 gearbox may be coupled with many of our other standard AC or DC motors.

For customers who require in excess of 5000 units per year we offer a totally bespoke design service to fit the application; at zero cost premium. This service enables customers to outline any number of mechanical, electrical, environmental or even aesthetic requirements in order to realise their preferred motor-gearbox solution.

To find out more please contact a member of our sales team on +44 (0)1202 512 575 or visit our website at www.parvalux.com for further information.

*Gearbox life may be less than 5000 hours. Contact us for application advice. † Maximum theoretical efficiency.

drawing for PM90-150 / PM90-180 / RE90-146 (rare earth) with GB12 gearbox

standard motor-gearbox configured and customised for your application

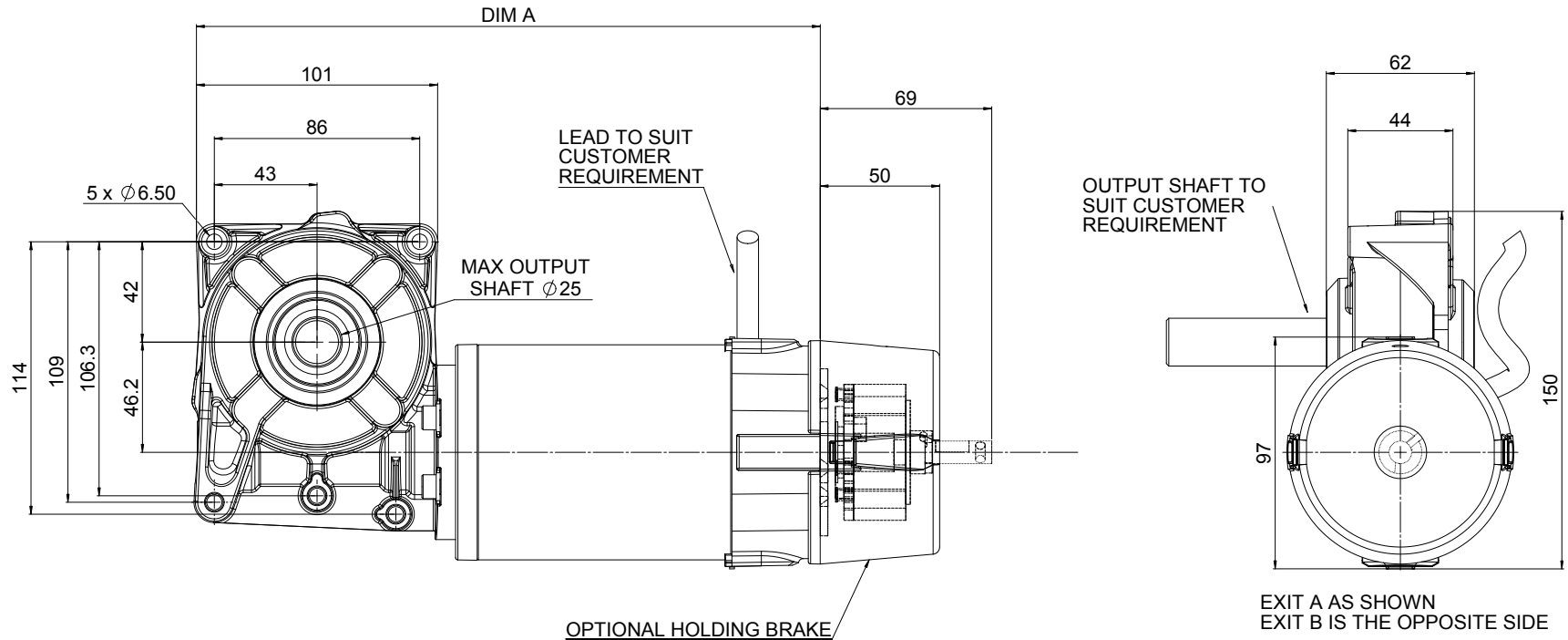

Motor Type	Motor Weight	Gearbox Weight with Delrin	Gearbox Weight with bronze	DIM A	
				Totally Enclosed	Ventilated
PM90-150	3.0 kg	1.1 kg	1.5 kg	263	277
PM90-180	4.0 kg	1.1 kg	1.5 kg	293	306
RE90-146	4.0 kg	1.1 kg	1.5 kg	259	274

All dimensions are in mm
 Many of our drawings are available in 3D format. Please contact us with your requirements
PORTUGAL
portugal@ermec.com
BILBAO
bilbao@ermec.com

ERMEC
 www.ermec.com
ERMEC, S.L. BARCELONA
 C/ Francesc Teixidó, 22
 E-08918 Badalona
 (Spain)

Tel.: (+34) 902 450 160
Fax: (+34) 902 433 088
info@ermec.com
www.ermec.com

ERMEC, S.L. MADRID
 C/ Sagasta, 8, 1ª planta
 E-28004 Madrid
 (Spain)

For customers who require in excess of 5000 units per year we offer a totally bespoke design service to fit the application; at zero cost premium. This service enables customers to outline any number of mechanical, electrical, environmental or even aesthetic requirements in order to realise their preferred motor-gearbox solution. To find out more please contact a member of our sales team on +44 (0)1202 512 575 or visit our website at www.parvalux.com for further information.