

# TH series

## Single-axis throttle joysticks

Distinctive features and specifications



- Rugged, hand operation
- Hall effect sensing
- Single axis friction clutch operation
- Optional mechanical detents and/or microswitches
- Redundant outputs available
- Sealed up to IP68

### MECHANICAL

- Break Out Force : 6.6N (1.50lbf)
- Operating Force: 7.7N (1.70lbf)
- Mechanical Angle of Movement: 70°
- Expected Life: 10 million cycles
- Mass/weight: Varies
- Material: Glass reinforced nylon
- Lever Action (Centering): Friction

### ELECTRICAL

- Sensor: Hall effect
- Resolution: Infinite
- Supply Voltage Operating: 5.00VDC
- Reverse Polarity Max: -14.5VDC
- Overvoltage Max: 18VDC
- Output Impedance: 6Ω
- Current Consumption Max: 10mA

### ENVIRONMENTAL

- Operating Temperature: -25°C to 70°C (-13°F to 158°F)
- Storage Temperature: -40°C to 70°C (-40°F to 158°F)
- Sealing (IP): IP65 to IP68\*
- EMC Immunity Level (V/M): IEC 61000-4-8:2009
- EMC Emissions Level: IEC 61000-4-3:2006
- ESD: IEC 61000-4-2:2008

### ELECTRICAL MICROSWITCH

- Electrical rating: 0.1 A at 30 VDC (resistive load)
- Insulation resistance: 100 MΩ min. (at 500 VDC)
- Contact resistance: 100 mΩ max.
- Dielectric strength: 600 VAC, 50/60 Hz for 1 min between terminals of the same polarity 1,000 VAC, 50/60 Hz for 1 minute between current-carrying metal parts and ground, and between each terminal and non-current-carrying metal parts
- Vibration resistance: Malfunction: 10 to 55 Hz, 1.5-mm double amplitude
- Shock resistance: Destruction: 1,000 m/s<sup>2</sup> (approx. 100G) max. Malfunction: 200 m/s<sup>2</sup> (approx. 20G) max.
- Durability: Mechanical: 1,000,000 operations min. (60 operations/min)  
Electrical: 100,000 operations min. (30 operations/min)
- Sealing: IP67 (excluding solder terminals)

### STANDARD SWITCH CHARACTERISTICS/RATINGS

- Electrical Resistive Load: 5A (depending on the chosen switch)
- Electrical Inductive Load: 3A (depending on the chosen switch)
- Low Level: 10mA @ 30mV (depending on the chosen switch)
- Electrical Life: 1 million cycles 5A @ 28 VDC resistive snap-action (depending on the chosen switch)
- Mechanical Life: 1million cycles
- Environmental Seal: IP67
- Action: Momentary, snap-action
- Operating Force: 1.7 lbs ± 0.5 lb
- Total Travel: 0.080 inches max
- Over Travel: 0.010 inches min

### NOTES:

- All values are nominal.
- Exact specifications may be subject to configuration.
- Contact Technical Support for the performance of your specific configuration.
- \* Excludes some handle options.

# TH series

## Single-axis throttle joysticks

### Overview

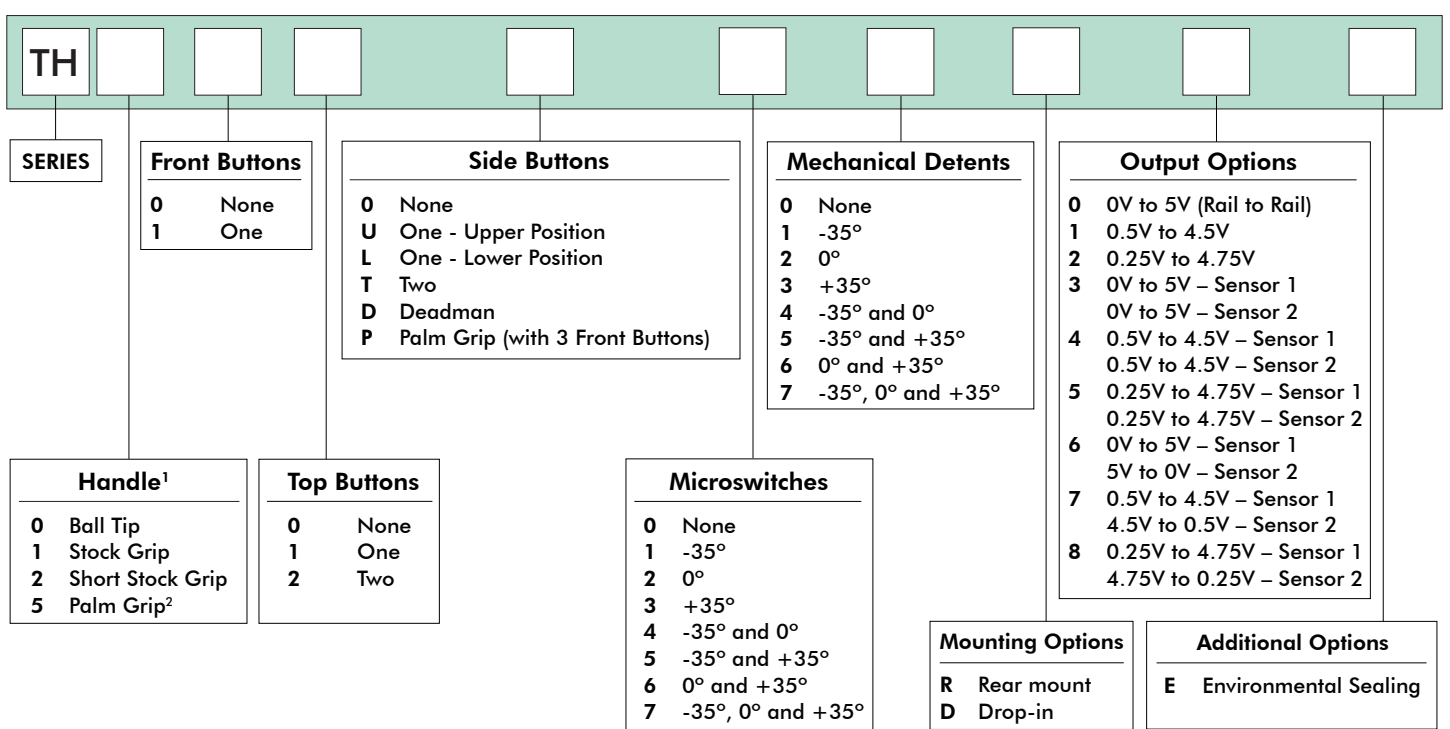

**NOTES:**

- See information on standard configurations for throttle handles.
- Palm Grip handle requires Drop-in mounting.



Up to IP68 available.



Mounting accessories. Standard hardware includes: 1 gasket, 4 screws (10-32x3/4 Phillips Flat Head), 4 washers (#10 Split Lock), 4 nuts (10-32 Hex). The gasket and the mounting hardware are shipped off the throttle, in a separate bag.

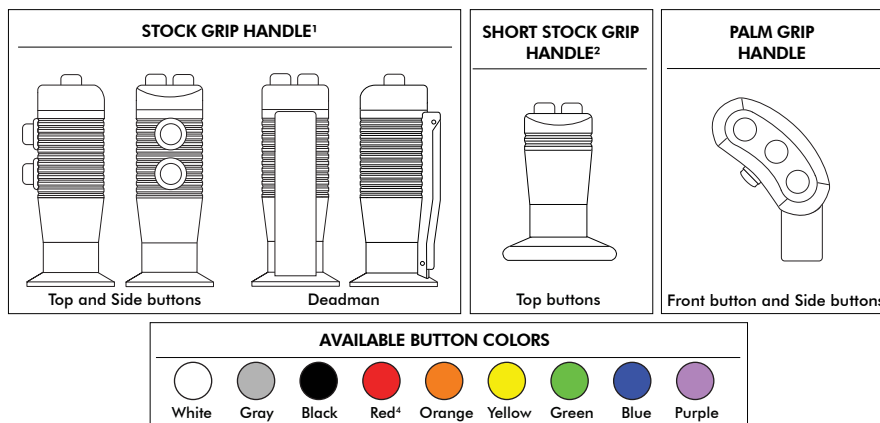

**NOTES:**

- The maximum possible configuration for the Stock Grip handle is up to 2 Top Buttons and 2 Side Buttons.
- The maximum possible configuration for the Short Stock Grip handle is up to 2 Top Buttons. It is not possible with Deadman, Index Trigger, or Side Buttons.
- For non-standard configurations contact Technical Support.
- If unspecified, the pushbuttons will have snap action momentary switches with red button caps.

# TH series

## Single-axis throttle joysticks

Overview

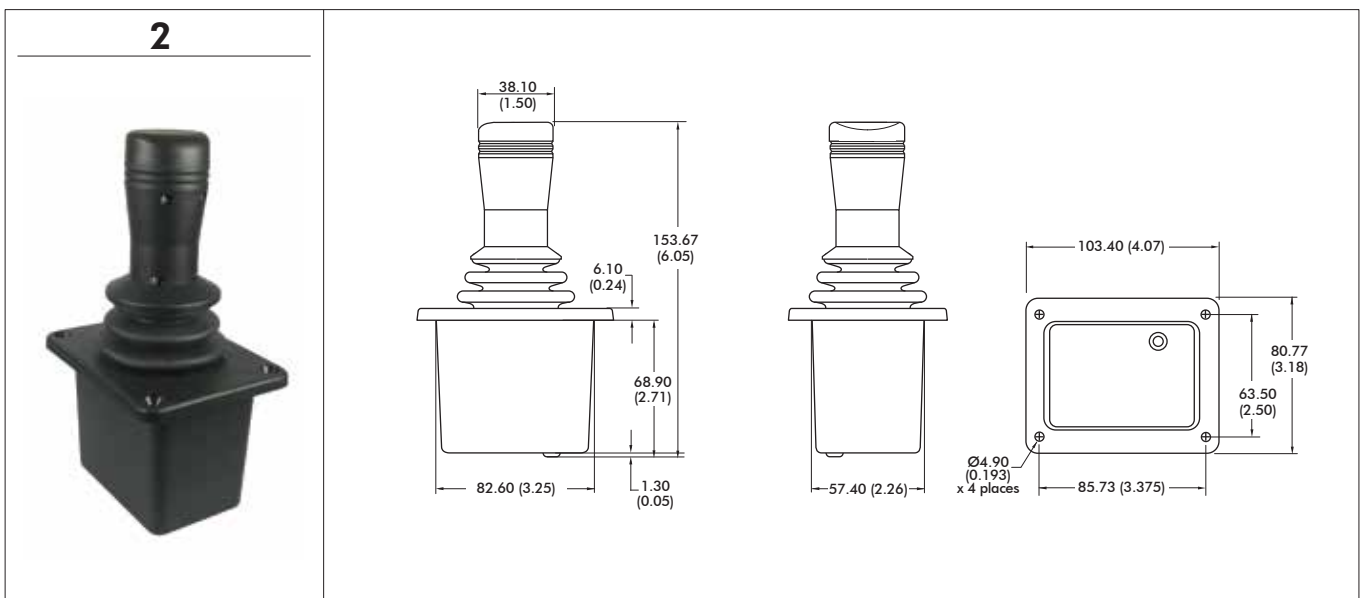
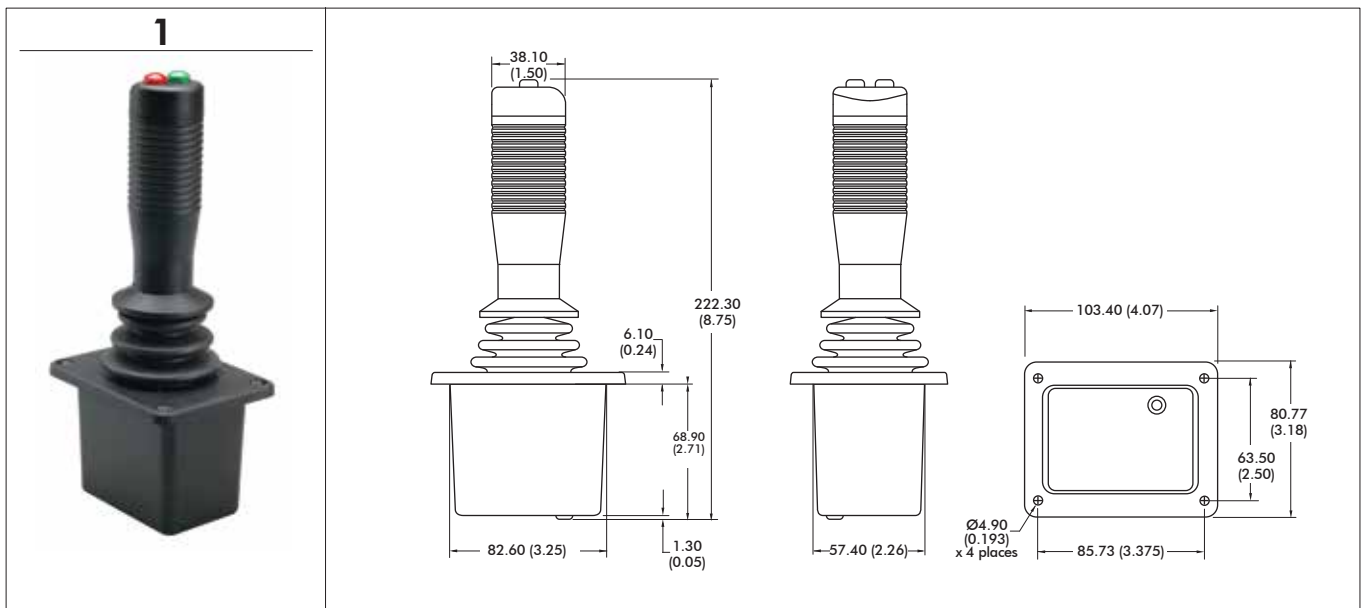
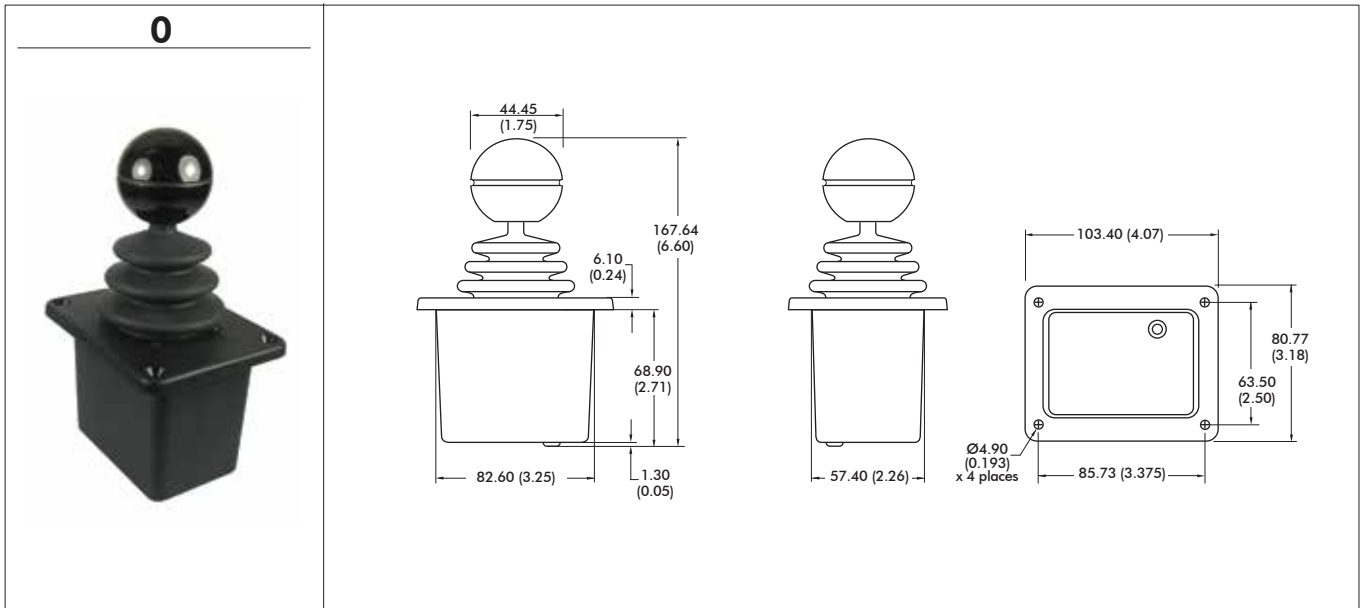

# TH series

## Single-axis throttle joysticks

### Overview

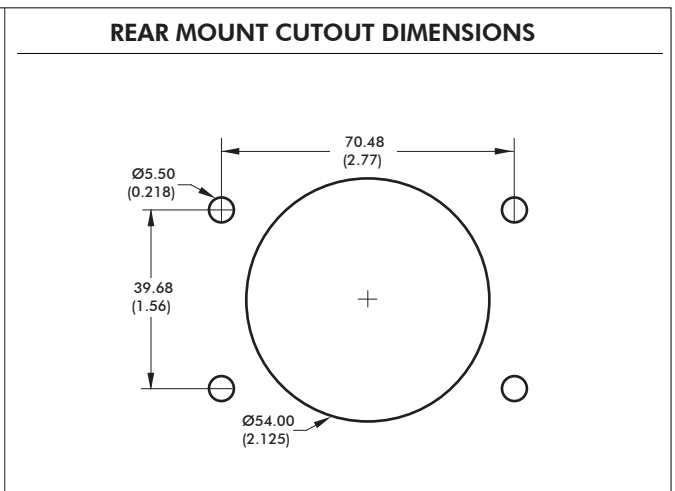
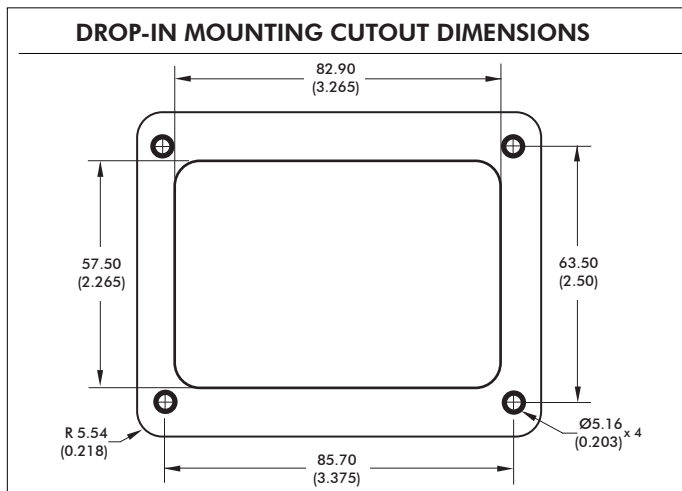
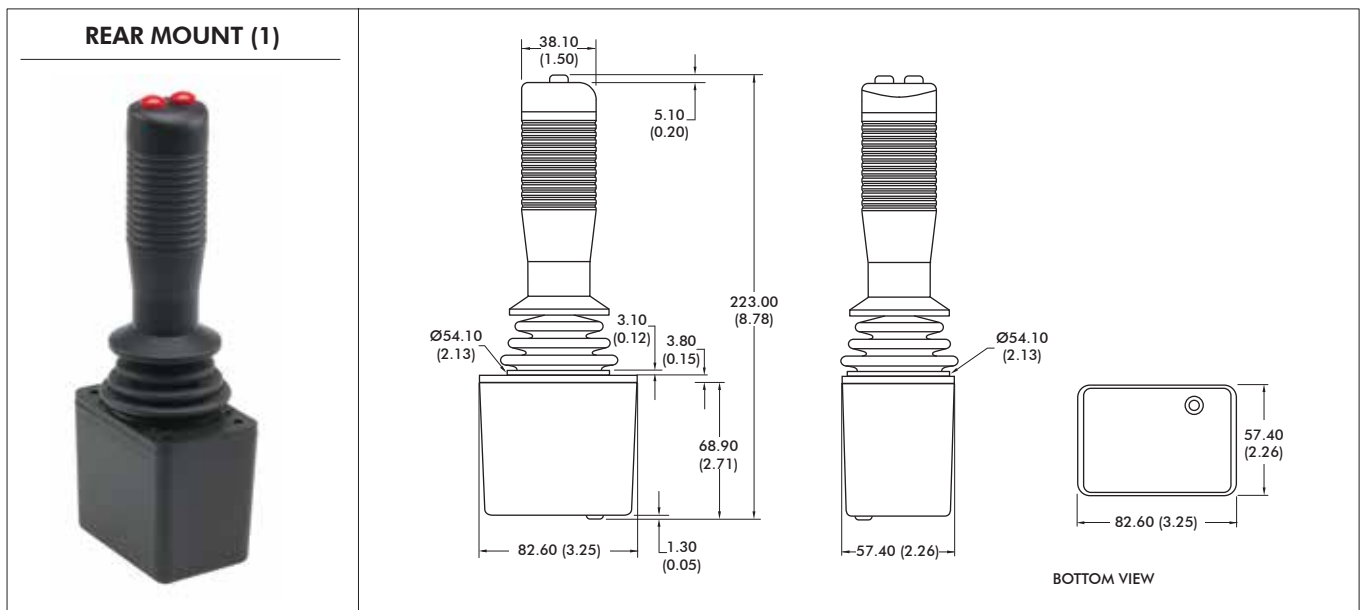
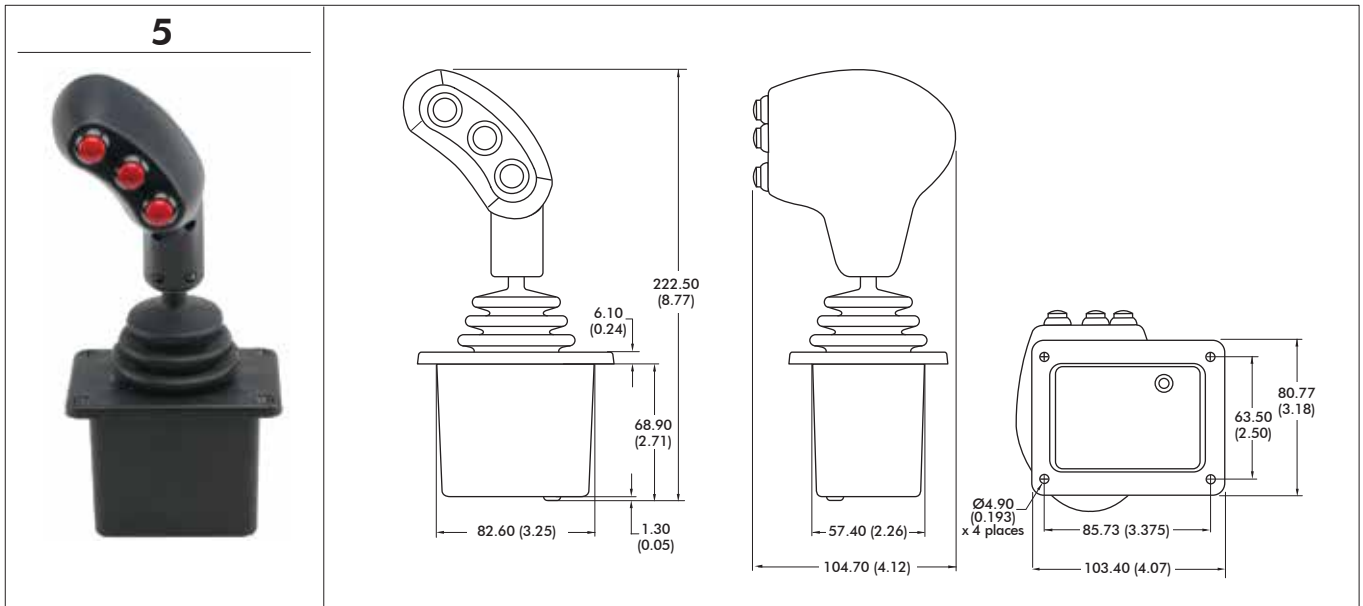

**NOTE:**

1. Dimensions are in mm/(inch).

# TH series

## Single-axis throttle joysticks

Overview

### VOLTAGE OUTPUT OPTIONS

