

### CARATTERISTICHE MECCANICHE - MECHANICAL SPECIFICATIONS

**Dimensioni - Dimensions:** vedi disegni - see drawings  
**Carico sull'albero - Shaft loading:** assiale - axial: 200 N; radiale - radial 200 N  
**Numero giri - Shaft rotational speed:** 10.000 RPM per brevi periodi - to short cycle time; 6.000 RPM continui - continuous  
**Coppia di partenza a 25° C - starting torque at 25° C:** 0,025 Nm  
**Momento d'inerzia - Moment of inertia:** 50 g cm<sup>2</sup>  
**Vita dei cuscinetti - Bearings life:** 5 x 10<sup>6</sup> giri (minimo) - rev. Min.  
**Peso - Weight:** ~ 0,5 kg

### CARATTERISTICHE ELETTRICHE - ELECTRICAL SPECIFICATIONS

**Frequenza in uscita - output frequency:** fino a 100 kHz up to 100 kHz  
**Sincronismo di zero - Synchronous index output:** Su canale A predefinito - on A default; B - A+B a richiesta - B - A+B optional  
**Assorbimento in corrente - Supply current without load:** 150 mA max.  
**Protezione - Protection:** contro il cortocircuito (solo elettronica LD2 e PP2); short circuit protection, no limit duration (only output LD2 and PP2)  
 contro inversione di polarità (escluso 5Vcc); against inversion of polarity (except 5Vcc)

### MATERIALI UTILIZZATI - MATERIALS

**Corpo - Flange:** in alluminio anticorrosione - aluminium anticorrosion  
**Custodia - Housing:** Poliammide 66 (Pa66); Polyamid 66 (Pa66)  
**Giunto -** Giunto integrato in alluminio serie GE - Flexible coupling GE series

### CARATTERISTICHE AMBIENTALI - ENVIRONMENTAL SPECIFICATIONS

**Temperatura di lavoro - Operating temperature range:** -10°C + +70°C  
**Temperatura di stoccaggio - Storage temperature range:** -30°C + +80°C  
**Umidità relativa - Relative humidity:** 98% RH senza condensazione - RH without condensing  
**Vibrazioni - Vibrations:** 10 g (da 10 a 2.000 Hz) - (From 10 up to 2.000 Hz)

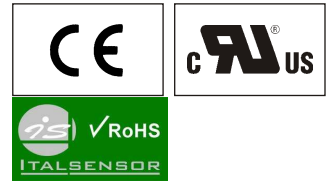

### CODICE DI ORDINAZIONE - ORDERING CODE

TKMXXXX . = . XXXX . XXXXX . X . XX . XX,XX . XXnn . XXX-XXXX . Xnnn

#### MODELLO - TYPE

TKM 7310 monodirezionale - unidirectional  
 TKM 7311monodir+ zero - unidirect + index  
 TKM 7320 bidirezionale - bidirectional  
 TKM 7321 bidirez.+ Zero - bidirect + index

#### MONTAGGIO - ASSEMBLY

= Standard - Default

#### IMPULSI GIRO - PULSE RATE

2 - 5 - 10 - 20 - 25 - 30 - 32 - 36 - 40 - 50 - 60 - 64 - 72 - 80 - 88 -  
 90 - 100 - 120 - 125 - 127 - 128 - 150 - 162 - 183 - 180 - 200 - 240  
 - 250 - 254 - 256 - 300 - 314 - 360 - 375 - 390 - 400 - 500 - 512 -  
 576 - 600 - 625 - 635 - 720 - 750 - 800 - 900 - 1000 - 1024 - 1200 -  
 1250 - 1270 - 1440 - 1500 - 1800 - 2000 - 2048 - 2500 - 2540 -  
 2700 - 3600

#### Alimentazione (Vdc) - Voltage supply

5 +5 V ± 5 %  
 11/30 +11V +30 V  
 24/5 +11/30 V supply + 5 V output

#### Frequenza in uscita - Output frequency

S da- from 0 a - up to 50 kHz  
 V da- from 0 a - up to 100 kHz

#### Grado di protezione - Protection class

K1 IP 55 (EN60529) solo connessione "PS" - only "PS" connection  
 K4 IP 64 (EN60529)

Custom

#### CIRCUITI DI USCITA - OUTPUT CIRCUITS

S NPN standard (resistenza di pull-up inclusa - resistor included)  
 OC NPN open collector  
 P PNP (resistenza di pull-down inclusa - resistor included)  
 OP PNP open collector  
 PP2-5 Push-Pull 5 V output  
 PP2-1130 Push-Pull 11/30 Vcc output (solo con alimentazione 11/30 V  
 (only with voltage supply 11/30 V)  
 LD Line driver RS422 (26LS31) solo - only 5 V o - or 24/5 V  
 LD2-5 Line driver 5 Vcc output  
 LD2-1130 Line driver 11/30 Vcc output (solo con alimentazione 11/30 V  
 (only with voltage supply 11/30 V)

#### CONNESSIONI ELETTRICHE - ELECTRICAL CONNECTIONS

**OUTPUT:** S ; P ; OC ; OP ; PP2 ; LD ; LD2 ; (escluso - except TKM7321)  
**Pnn** pressacavo assiale con cavo da 1 a 6 m; on axial cable gland with cable 1 ÷ 6 m long  
**PLnn** pressacavo radiale con cavo da 1 a 6 m; radial cable gland with cable 1 ÷ 6 m long  
**PSnn** gommino passacavo radiale con cavo da 1 a 6 m;  
 cap radial cable gland with cable 1 ÷ 6 m long  
**S 07** connettore circolare militare assiale a 7 poli; on 7 pins axial MIL connector  
**L 07** connettore circolare militare radiale a 7 poli; on 7 pins radial MIL connector

**OUTPUT:** LD ; LD2 (solo - only TKM7321)  
**Pnn** pressacavo assiale con cavo da 1 a 6 m; on axial cable gland with cable 1 ÷ 6 m long  
**PLnn** pressacavo radiale con cavo da 1 a 6 m; radial cable gland with cable 1 ÷ 6 m long  
**PSnn** gommino passacavo radiale con cavo da 1 a 6 m;  
 cap radial cable gland with cable 1 ÷ 6 m long  
**S 10** connettore circolare militare assiale a 10 poli; on 10 pins axial MIL connector  
**L 10** connettore circolare militare radiale a 10 poli; on 10 pins radial MIL connector  
**R1** connettore circolare "contact" radiale a 12 poli; on 12 pins radial "contact" connector

nn Lunghezza cavo - Cable length (es. PL10 = 1 m. ... PL60 = 6 m)

#### Albero - Shaft

6 Ø 6 mm  
 8 Ø 8 mm  
 9,52 Ø 9,52 mm  
 10 Ø 10 mm

## MONTAGGIO MECCANICO MECHANICAL ASSEMBLY

= Standard  
= Default

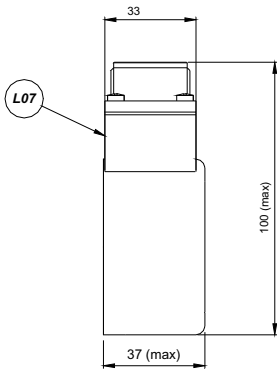
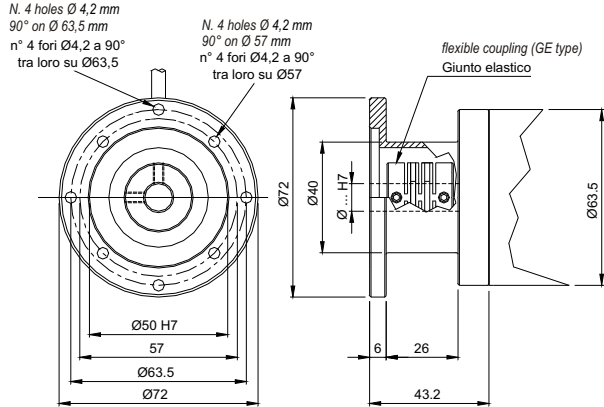

Pressacavo metallico per elettroniche LD / LD2

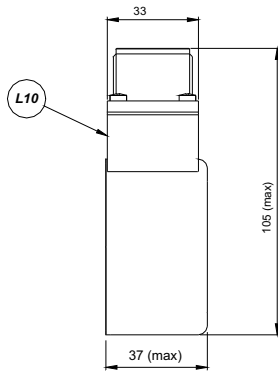
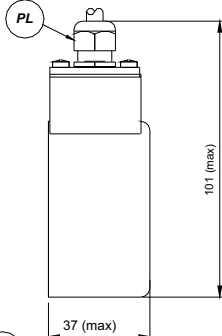

Pressacavo plastico elettroniche S/OC/P/OP/PP/PP2

