



CARATTERISTICHE MECCANICHE - MECHANICAL SPECIFICATIONS

Dimensioni - Dimensions: vedi disegni - see drawings
Albero - Shaft: acciaio inox - stainless steel
Carico sull'albero - Shaft loading: assiale - axial: 20 N; radiale - radial 10 N
Accelerazione angolare massima - Permissible angular acceleration: 10° rad/s²
Momento di inerzia - Moment of inertia: tipico - typically 2.5 * 10⁻⁶ kg m²
Numero giri - Shaft rotational speed: 12000 RPM continui
Vita dei cuscinetti - Bearings life: 3.9 x 10⁹ giri (minimo) - rev. min. @ 6000 RPM, 60 °C, 5 N radial, 10 N axial
Peso - Weight: ~ 0,5 kg

CARATTERISTICHE ELETTRICHE - ELECTRICAL SPECIFICATIONS

Codici STD - STD codes: Programmabili GRAY - BINARIO - GRAY - BINARY programmable
SSI: frequenza clock - clock frequency 80 kHz + 1 MHz; tempo di monoflop - monoflop time 16 µs ± 25 µs, tipico - typically 20 µs
Protezione - Protection: contro inversione di polarità; against inversion of polarity
Potenza assorbita - power dissipation (no load): < 3W

MATERIALI UTILIZZATI - MATERIALS

Corpo - Flange: in alluminio anticorrosivo - aluminium non corroding
Custodia - Housing: alluminio ossidato; oxidated aluminium

CARATTERISTICHE AMBIENTALI - ENVIRONMENTAL SPECIFICATIONS

Temperatura di lavoro - Operating temperature range: -20 + +70 °C
Temperatura di stoccaggio - Storage temperature range: -30 + +80 °C
Umidità relativa - Relative humidity: 98% RH senza condensazione - RH without condensing
Vibrazioni - Vibrations: DIN EN 60068-2-6: 1996, Shock DIN EN 60068-2-27: 1995
Tempo di inizializzazione - warm up time: 1 s



CODICE DI ORDINAZIONE - ORDERING CODE

TSM60P . XX . 8192 . XXXX . G . XXXXX . XX . XXXX . XXnn . XXXX . XXX . XXXX

MONTAGGIO - ASSEMBLY

F Flangia Quadra - Square flange
 S Flangia Servo - Servo-flange
 SG Servo-Graffe - Servo-clip

PASSI PER GIRO - STEPS

8192 programmabile da 2 a 8192 passi/giro
 From 2 to up 8192 steps/turn programmable

NUMERO GIRI - TURNS

4096 programmabile da 1 a 4096 giri
 from 1 to up 4096 turns programmable

CODICE - CODE

G codice Gray naturale Natural Gray code
 Programmabile - Programmable
 Gray - Binary

Alimentazione (Vdc) - Voltage supply

11/27 +11V +27 V

Grado di protezione - Protection class

K5 IP 65 (DIN EN 60529: 1991)

Albero - Shaft

6 Ø6 mm (SG)
 10 Ø10 mm (S, F)

OPZIONI - OPTIONS

W Up/Down PNP (Decrescente-DOWN aperto-open o-or <= 2 V, UP>= 8V fino a - up to 30 V)
 T Zero Set PNP (>= 8 V fino a-up to 30 V)

INTERFACCIA DI PROGRAMMAZIONE - SERIAL INTERFACE

485 Interfaccia programmazione RS485 Program interface RS 485

Per la programmazione richiedere l'apposito adattatore codice TSM60P-PT
 In order to program the device you must require the dedicated adapter model TSM60P-PT

CIRCUITI DI USCITA - OUTPUT CIRCUITS

S25C SSI 25 bit allineato al centro - SSI 25 bit center alignment (tree format)

Formato programmabile (standard / albero) - programmable format (standard / tree format)

CONNESSIONI ELETTRICHE - ELECTRICAL CONNECTIONS

SL 12 connettore circolare radiale a 12 poli; on 12 pins radial connector

Connessione tipo "T" - "T" type connection
 Femmina volante cod. 1E2A212H - Mating female connector cod. 1E2A212H

Connettore maschio 12 poli
 12 poles male connector

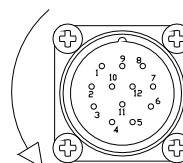

- Pin 1 : 0V
- Pin 2 : DATA+
- Pin 3 : CKI+
- Pin 4 : PROGR+ (RS485)
- Pin 5 : N.C.
- Pin 6 : PROGR- (RS485)
- Pin 7 : N.C.
- Pin 8 : +Vcc
- Pin 9 : Zero Set
- Pin 10 : DATA-
- Pin 11 : CKI-
- Pin 12 : UP/DOWN

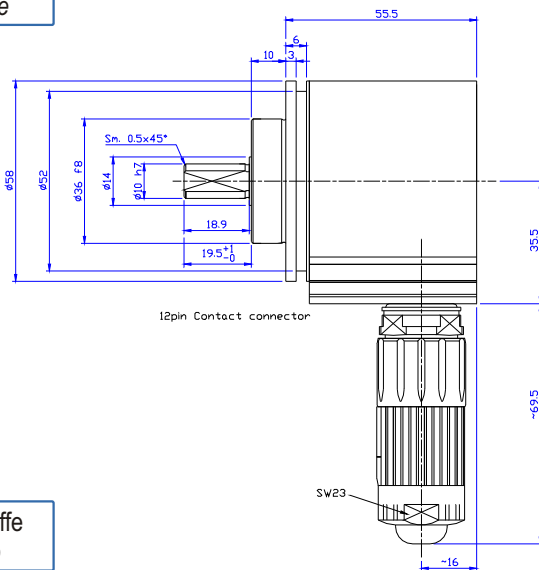
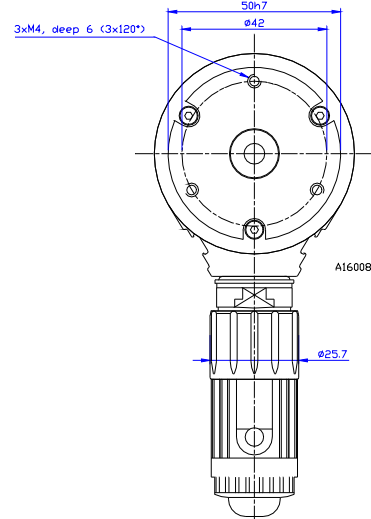
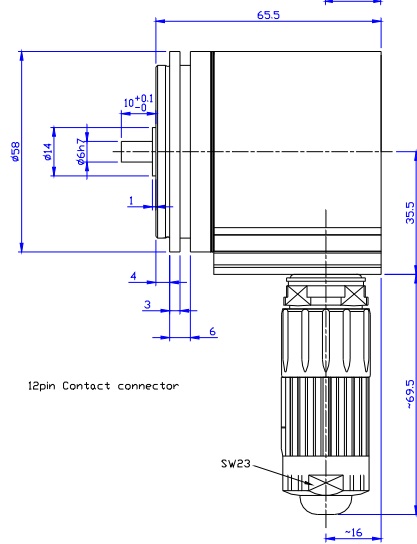
S Flangia servo
S Servo flange

SG Servo-graffe
SG Servo-clip

F Flangia Quadra
F Square flange
