

# EM-106 BRUSHLESS DC-MOTOR CONTROL UNIT 12-24V 5A

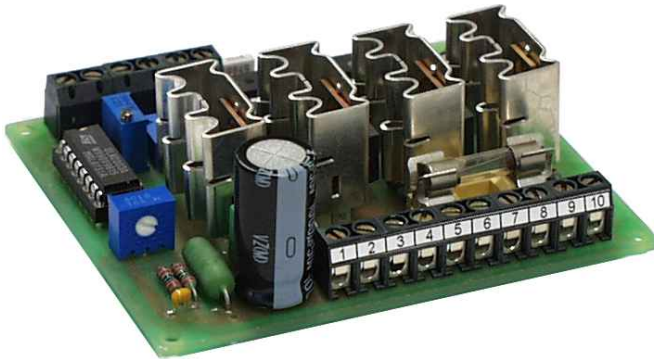

## FEATURES:

- Three phase output
- Direction change
- Hall-transducer supply and input
- Supports 60° and 120° commutating
- Adjustable current limit
- Direct or freq.locked driving
- High efficiency
- Inbuilt fuse
- Rail mounting base available

EM-106 controller is designed for brushless hall-feedback DC-motors. The device uses mosfet-type power stage with high efficiency. EM-106 can be connected to 60- or 120 degrees commutating motor. Standard driving includes speed adjustment, stopping, direction change and braking. The controller can be installed using screws or a standard rail mounting base.

There are two control modes: Within direct driving mode the motor voltage is set in proportion to the control voltage as with a normal DC-motor. Alternatively in frequency locked mode the controller uses the hall-transducer signal to speed adjustment besides commutating. This mode gives very precise speed referenced to the control voltage. As an additional feature the controller has an adjustment for loop response so that it provides as stable control as possible within all applications. Control input can be scaled with a trim. The current limit is set with a trim, it restricts driving when motor current exceeds the given value. The controller is protected against reversed input voltage polarity and fuse protected against over current.

## TECHNICAL DATA:

Supply voltage	12...36 Vdc
Idle current	approx. 30 mA
Control current	5 A cont. 8A 50/50%
Current limit	1...8 A
Voltage loss /V	0,8 V (Im=5 A)
Control voltage	0...10 V
Control pot.	2...10k
Control input	10 V max (20 mA)
Hall-input	6,5 V
Digital control	"on" at Uin 3...30 V "off" at Uin 0...1 V or open
Dimensions	87*73*35 mm
Weight	approx. 90 g

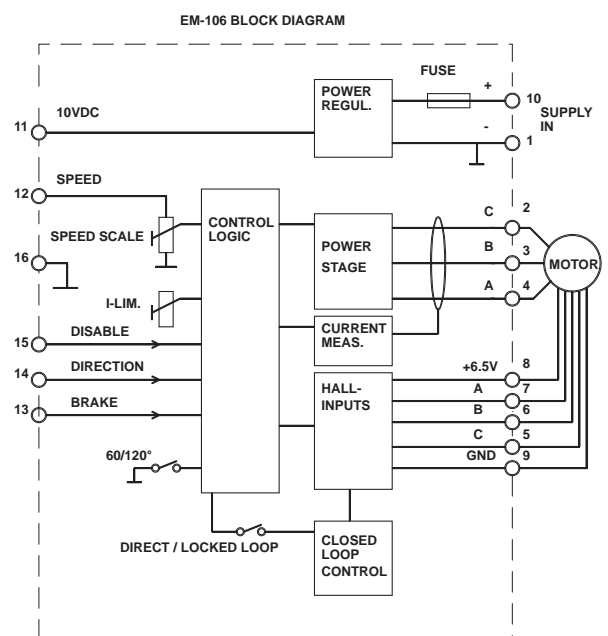

ERMEC, S.L. BARCELONA  
C/ Francesc Teixidó, 22  
E-08918 Badalona  
(Spain)

Tel.: (+34) 902 450 160  
Fax: (+34) 902 433 088  
[info@ermec.com](mailto:info@ermec.com)  
[www.ermec.com](http://www.ermec.com)

ERMEC, S.L. MADRID  
C/ Sagasta, 8, 1ª planta  
E-28004 Madrid  
(Spain)

PORTUGAL  
[portugal@ermec.com](mailto:portugal@ermec.com)  
BILBAO  
[bilbao@ermec.com](mailto:bilbao@ermec.com)

# EM-106 OPERATING INSTRUCTIONS

Operating voltage 12-36V filtered, less than 20% ripple.

Speed control set with voltage or potentiometer. Range is adjustable with SCALE and ZERO trim.  
Speed control mode NORMAL or CLOSED LOOP is selected with SW1.

Normal speed control: Motor acts like normal DC-motor without feedback.

Closed loop control: The control unit uses a hall sensor signal to regulate motor speed.

Accuracy of motor rpm is typically  $\pm 1\%$  in this mode.

The desired rpm range in closed loop mode is selected with SW3.

Synchro control:

A SYNCHRO OUT feature can be used if phase locking loop (PLL) control (clock accuracy, frequency control) is needed. This control mode needs external PLL-unit.

Current limit adjust ( I-LIM ) limits the motor current ( torque ).

Commutation phase of motor is selected with SW2.

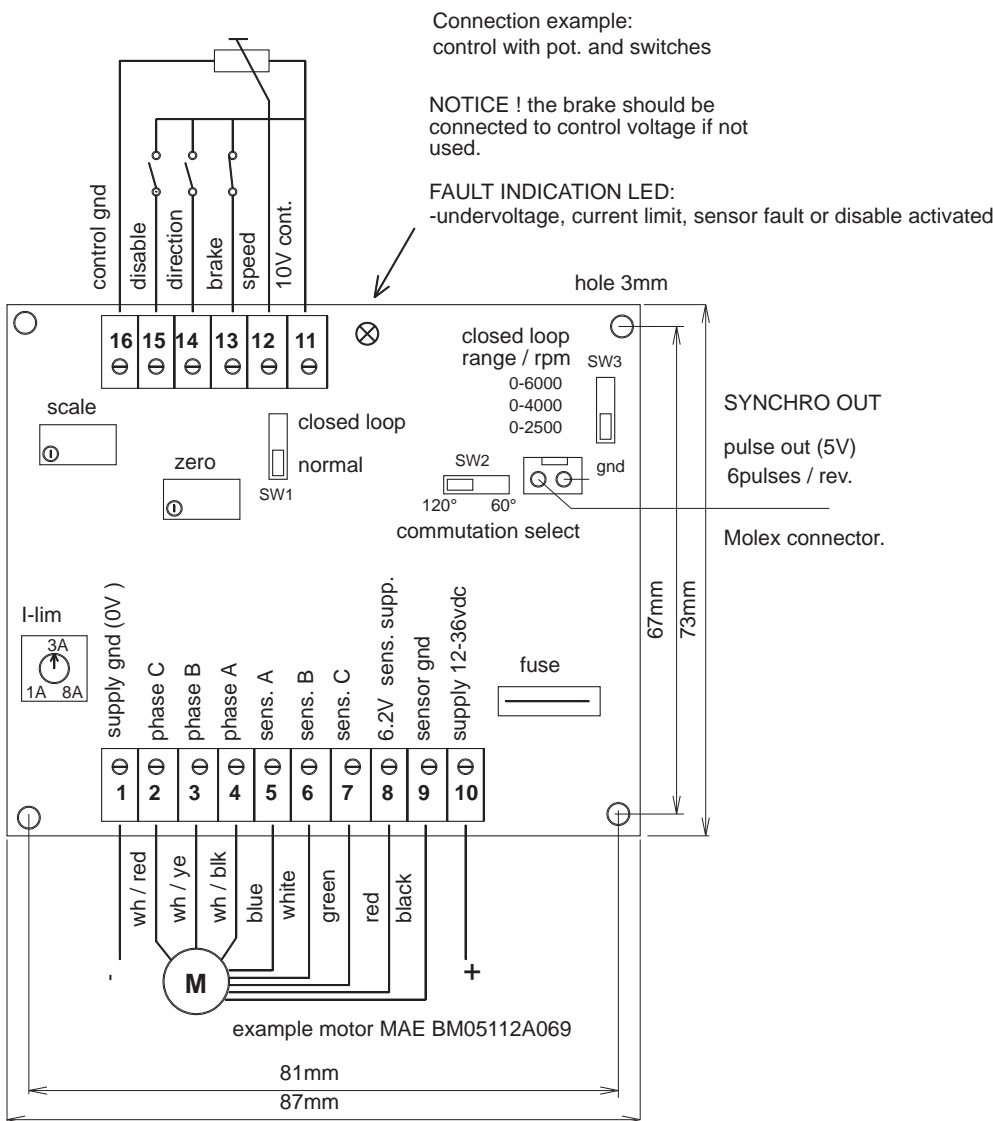

**ERMEC, S.L. BARCELONA**  
C/ Francesc Teixidó, 22  
E-08918 Badalona  
(Spain)

**Tel.: (+34) 902 450 160**  
**Fax: (+34) 902 433 088**  
[info@ermec.com](mailto:info@ermec.com)  
[www.ermec.com](http://www.ermec.com)

**ERMEC, S.L. MADRID**  
C/ Sagasta, 8, 1ª planta  
E-28004 Madrid  
(Spain)

**PORTUGAL**  
[portugal@ermec.com](mailto:portugal@ermec.com)  
**BILBAO**  
[bilbao@ermec.com](mailto:bilbao@ermec.com)