

EM-M50 8-CHANNEL ALARM PANEL

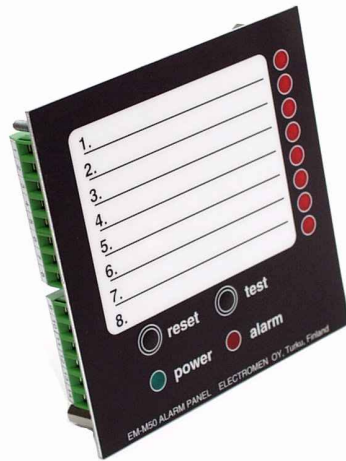

FEATURES:

- 8-channels
- Selectable input mode n.o. or n.c. alarm contacts
- Settable input delay
- Settable alarm output delay
- Relay output for alarm
- Blinker and memory for alarm
- Realtime indication
- Invertable outputs
- Test function
- Standard panel mounting size
- Protected against inverse polarity

EM-M50 is an 8-channel alarm logic suitable for alarm control in various automation processes. EM-M50 can be installed to standard 96*96 millimeter slot. Each of the 8-channels can be set to activate either with opening or closing contact. Inputs can be controlled with voltage signal also. The indication output display the state of the input in realtime so the unit is s.c. transparent. Indication outputs can be inverted as well, then the output is reversed compared to input.

The alarm logic operates in following manner. When the fault signal is detected, the indication light of the particular channel starts to blink and group alarm relay and alarm output gives an alarm. If the fault causing the alarm is removed the alarm stays. The alarm can be removed only with reset button. When the alarm is acknowledged the group alarm is removed, indication light stays lit until the input situation has been normalized. So new alarm blinks and old one stays lit. The alarm input can be delayed for 0.5 to 4 seconds. Alarm output can be delayd for 0 to 10 seconds. Delay is the same for all channels. Operation of the unit can be verified with test button. EM-M50 is equipped also with test and reset inputs. With these inputs several units can be connected in parallel to form groups.

The group alarm relay is de-energized when alarm occurs so an operating voltage failure causes an alarm as well. Operating voltage input is protected against voltage surges and inversed voltage.

TECHNICAL DATA:

Supply	12...32 Vdc
Current consumption	200 mA
Input levels	"0" < 1 V "1" > 4 V
Input voltages	max. ±35 V
Input impedances	10 kohm (in 1-8)
Relay output	1 A 125 Vac / 30 Vdc
Transistor output	NPN-open collector
Load capacity of output	120 mA
Alarm delays	0.5 ... 4 s
Output delay	0 ... 10 s
Oper. ambient temp.	0...50 °C
Mounting hole	92*92 or 88*88 mm
Dimensions	96*96*40 mm
EMC-tested and CE-marked	

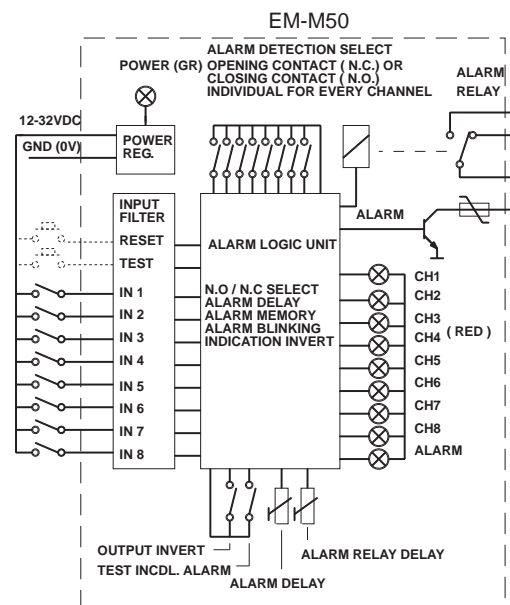

ERMEC, S.L. BARCELONA
C/ Francesc Teixidó, 22
Parque Empresarial Granland
E-08918 Badalona (Sur)

Tel.: (+34) 902 450 160
Fax: (+34) 902 433 088
info@ermec.com
www.ermec.com

ERMEC, S.L. MADRID
C/ Sagasta, 8 1ª planta
E-28004 Madrid
(Spain)

PORTUGAL
portugal@ermec.com

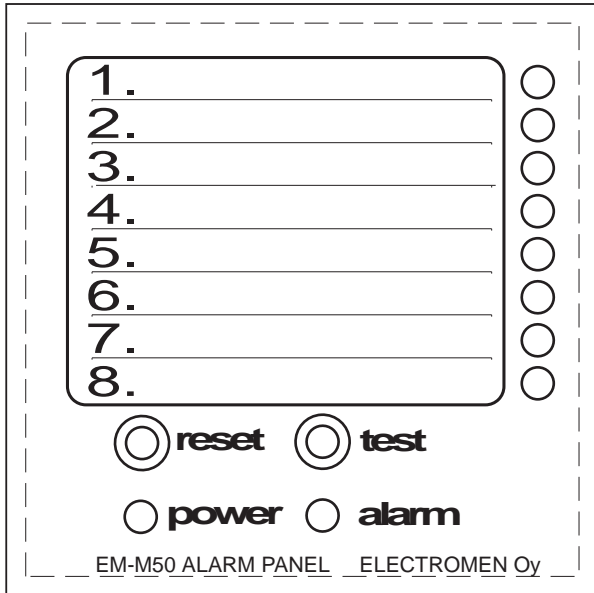

ALARM INDICATIONS FOR EACH CHANNEL
RED LED LIGHTS

MOUNTING HOLE MIN. 88x88 mm
MAX. 92x92 mm
FREE DEPTH MIN. 40 mm

ALARMS, CHANNELS 1-8

SWITCH "ON" = OPENING CONTACT OR $U_{in} < 1.5V$
CAUSES AN ALARM
SWITCH "OFF" = CLOSING CONTACT OR $U_{in} > 4V$
CAUSES AN ALARM
NUMBER OF SWITCH INDICATES THE CHANNEL.
IF THE INPUT IS NOT USED SET SWITCH "OFF"

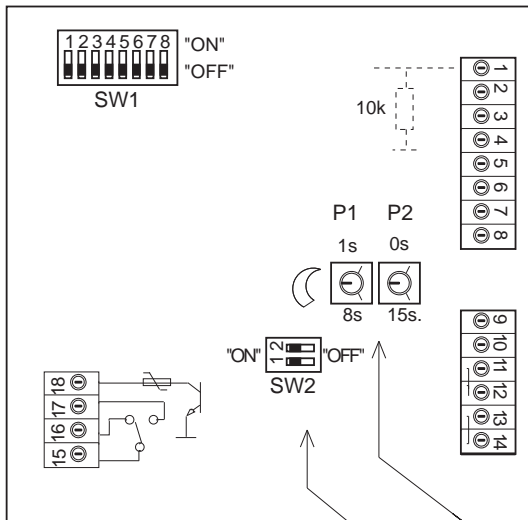

ALARM INPUTS 1-8

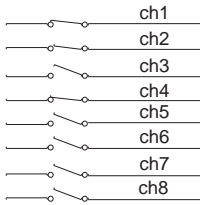

ALARM INPUTS 1 - 8 INPUT IMPEDANCE 10k. CAN BE CONTROLLED WITH CONTACT OR VOLTAGE SIGNAL
MAX. $\pm 35V$, LIMITS "0" $< 1V$ AND "1" $> 4V$

AUX. INPUTS FOR RESET AND TEST CAN BE CONNECTED ACCORDING TO THE PICTURE IF EXTERNAL CONTACTS ARE USED.
IF THERE ARE SEVERAL PANELS IN ONE GROUP, THE RESET INPUT (19) CAN BE LINKED TOGETHER. SAME WAY THE TEST INPUTS (10) CAN BE OPERATED WITH ONE CONTACT.

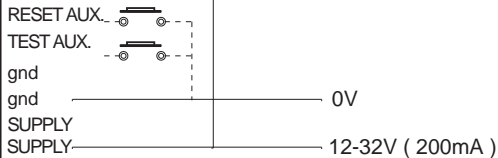

ALARM OUTPUTS

NPN - TRANSISTOR MAX. 100 mA
RELAY 1A / 125Vac / 30 Vdc
RELAY PICTURED IN NORMAL CONDITION

P1 IS A DELAY ADJUSTMENT FOR ALARM INPUTS IT CAN BE SET FROM 1 TO 8 SECONDS.
P2 IS A DELAY ADJUSTMENT FOR RELAY OUTPUTS IT CAN BE SET FROM 0 TO 15 SECONDS.

SW2 CONTACT 1 IS FOR INVERTING THE OPERATION
"ON" = NORMAL OPERATION "OFF" = INVERTED OPERATION

SW2 CONTACT 2 IS TO DETERMINE THE TEST OPERATION
"ON" = RELAY OUTPUT NOT RESPONDING TO TEST BUTTON
"OFF" = RELAY OUTPUT RESPONDING TO TEST BUTTON



ERMEC
www.ermec.com
ERMEC, S.L. BARCELONA
C/ Francesc Teixidó, 22
E-08918 Badalona
(Spain)

Tel.: (+34) 902 450 160
Fax: (+34) 902 433 088
info@ermec.com
www.ermec.com

ERMEC, S.L. MADRID
C/ Sagasta, 8, 1ª planta
E-28004 Madrid
(Spain)

PORTUGAL
portugal@ermec.com
BILBAO
bilbao@ermec.com