

Standard module with 9 ATO fuses, 2 mini relays

PART NUMBER: 175259

CHARACTERISTICS



- Suitable for 12 V and 24 V applications
- Power supply via power elements up to max. 70 A
- 7 fuse sockets for ATO fuses up to max. 15 A
- 2 additional sockets for ATO fuses up to max. 30 A for relay protection
- 2 mini relay sockets 5 pin
- Rear connector 18 pin, 3 rows – JPT and MCP compatible
- High thermal load
- Shock and vibration resistant
- Also available with populated board (relays, fuses resp. automatic circuit breakers supressor diodes)

APPLICATIONS

- Power distribution within the automotive segment, such as alternators, control and indication devices, radio, accessories etc.
- Applicable individually or modular

TECHNICAL DATA

Operational temperature	-40° C to +85° C
Max. power supply	Max. 70 A at 65° C ambient temperature Max. 65 A at 80° C ambient temperature
Output	Connector 3 row, 18 pin, JPT/MCP compatible
Input	Power element socket M5, max. torque: 2.2 Nm (other designs on request)
Recommended cable cross-section for connector*	Current $I \leq 15$ A: 7.5 A per mm ² Current $I > 15$ A: 5 A per mm ²

*Note derating of connector

Standard module with 9 ATO fuses, 2 mini relays

PART NUMBER: 175259

DIMENSIONS

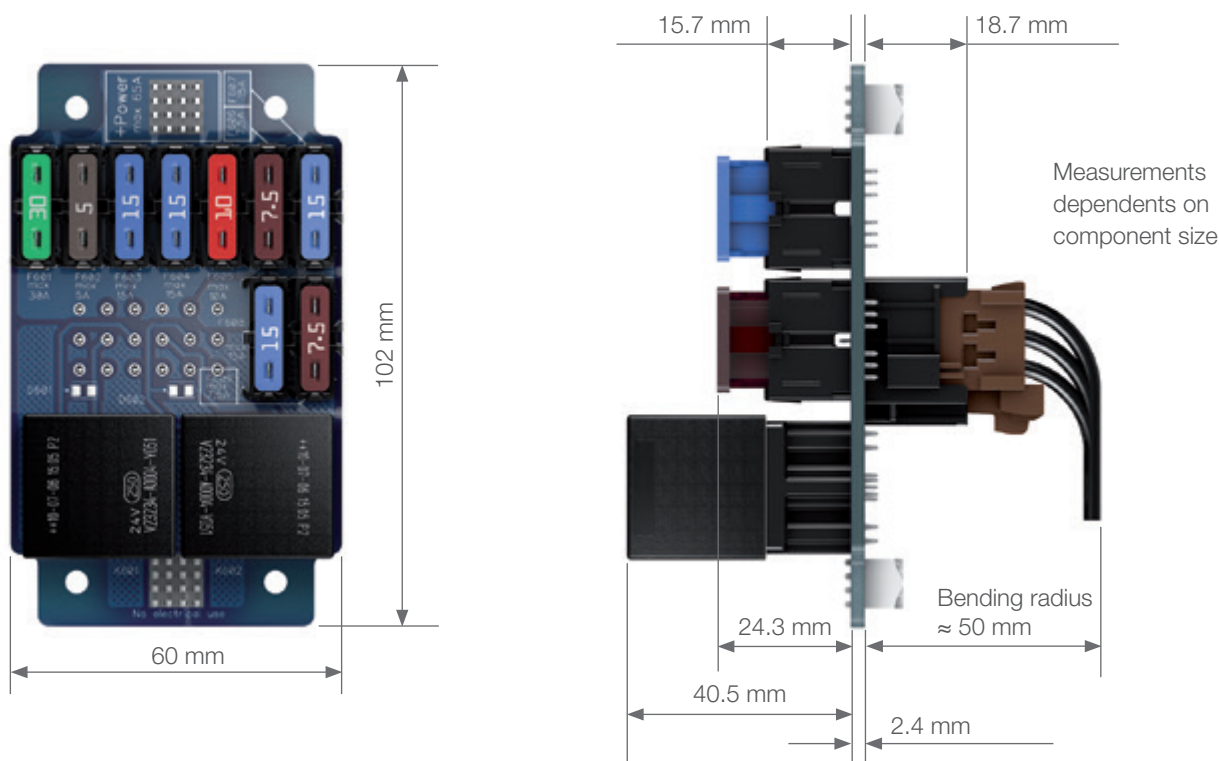

ELECTRIC CIRCUIT DIAGRAM

*optional

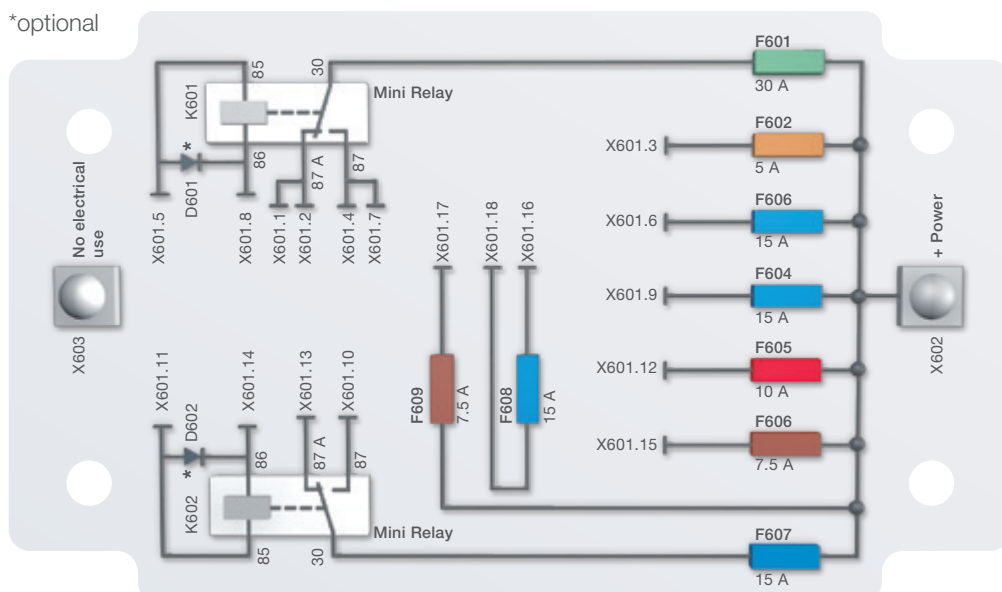

CAUTION: Note maximum supply current