



- Completely sealed switching chamber
- Three types of terminals
- UL approved

### ELECTRICAL SPECIFICATIONS

- Max. current/voltage rating with resistive load and electrical life at full load: see table below
- Initial contact resistance : 10 mΩ max. at 1A 2VDC
- Insulation resistance : 1.000 MΩ min. at 500VDC
- Dielectric strength : 2.500 Vrms 50 Hz min. between terminals  
3.000 Vrms 50 Hz min. between terminals and frame

### ELECTRICAL RATING AND LIFE

FUNCTIONS	Alternate current	Direct current	UL
ON-OFF and ON-ON	15A 125/250VAC resistive 10.000 cycles	15A 28VDC resistive 5A 28VDC lamp load 10.000 cycles	10A 125/250 VAC according to UL 1054
Other functions	10A 125/250VAC resistive 10.000 cycles	10.000 cycles 15A 28VDC resistive 3A 28VDC lamp load	

### MATERIALS

- Case : mineral filled polyester UL94-V0
- Bushing and cover : zamac
- Actuator : bright nickel
- Contacts : silver alloy  
Gold plated : on request

### AGENCY APPROVAL



File E83438

**Availability** : consult factory for details of approved models.

**Marking** : to order switches marked UL, complete appropriate box of ordering format.

### GENERAL SPECIFICATIONS

- Torque : 2 Nm (1.47 Ft.lb) max. applied to nut
- Panel thickness : see "Mounting Accessories" on the following pages
- Mechanical life : 40.000 cycles
- Operating temperature : -40°C to +85°C
- Front panel sealing : IP67

# CT series

## Sealed toggle switches

### Overview

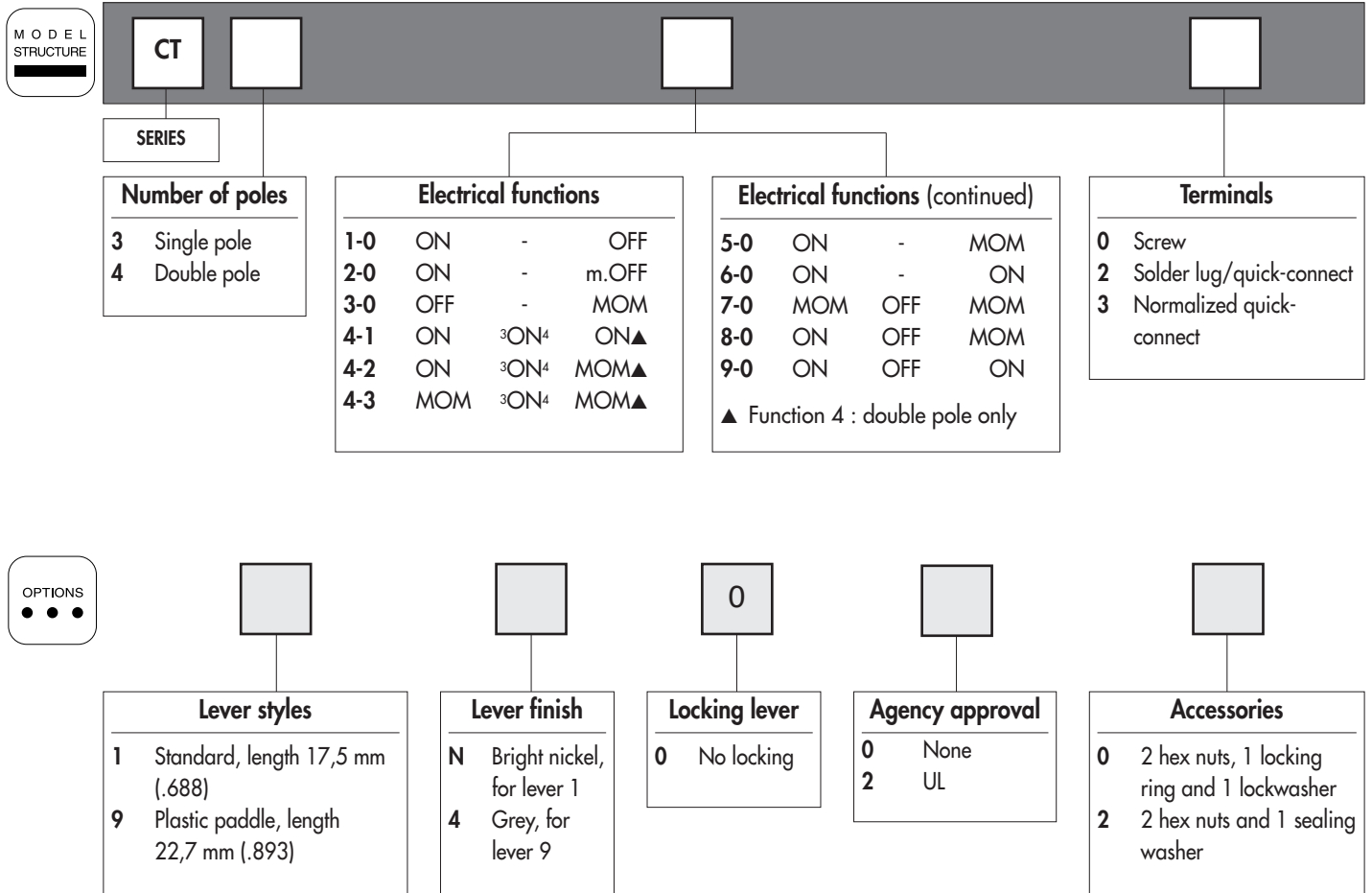

APEM has the ability to develop custom configurations. Please contact us with your requirements.



**NOTICE** : please note that not all combinations of above numbers are available. Refer to the following pages for further information.

#### ABOUT THIS SERIES

On the following pages, you will find successively :

- model structure of switches
- their options in the same order as in above chart

**Dimensions** : first dimensions are in mm while inches are shown as bracketted numbers.

**Security caps** are available to prevent inadvertent lever operation. On request.



**Packaging unit** : 25 pieces



# CT series

## Sealed toggle switches

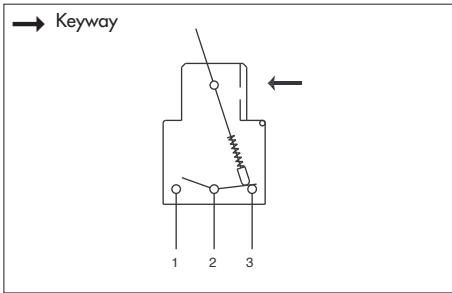

- Screw, solder lug or quick-connect terminals

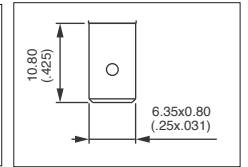
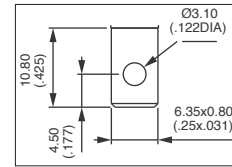
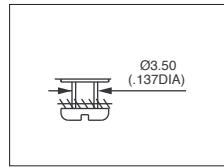

MODEL  
STRUCTURE

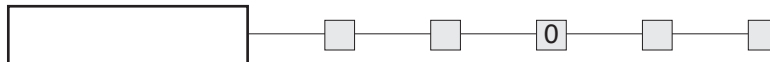

Shown with standard lever



FUNCTIONS			BASIC PART NUMBER					
III	II	I	Screw terminals		Solder lugs and quick-connect term.		Normalized quick-connect terminals	
A2-A3	*A3-B4	A1-A2	Single pole	Double pole	Single pole	Double pole	Single pole	Double pole
B5-B6	A1-B6	B5-B4						
ON	-	OFF	CT31-00	CT41-00	CT31-02	CT41-02	CT31-03	CT41-03
ON	-	m.OFF	CT32-00	CT42-00	CT32-02	CT42-02	CT32-03	CT42-03
OFF	-	MOM	CT33-00	CT43-00	CT33-02	CT43-02	CT33-03	CT43-03
ON	ON*	ON		CT44-10		CT44-12		CT44-13
ON	ON*	MOM		CT44-20		CT44-22		CT44-23
MOM	ON*	MOM		CT44-30		CT44-32		CT44-33
ON	-	MOM	CT35-00	CT45-00	CT35-02	CT45-02	CT35-03	CT45-03
ON	-	ON	CT36-00	CT46-00	CT36-02	CT46-02	CT36-03	CT46-03
MOM	OFF	MOM	CT37-00	CT47-00	CT37-02	CT47-02	CT37-03	CT47-03
ON	OFF	MOM	CT38-00	CT48-00	CT38-02	CT48-02	CT38-03	CT48-03
ON	OFF	ON	CT39-00	CT49-00	CT39-02	CT49-02	CT39-03	CT49-03

→ Keyway

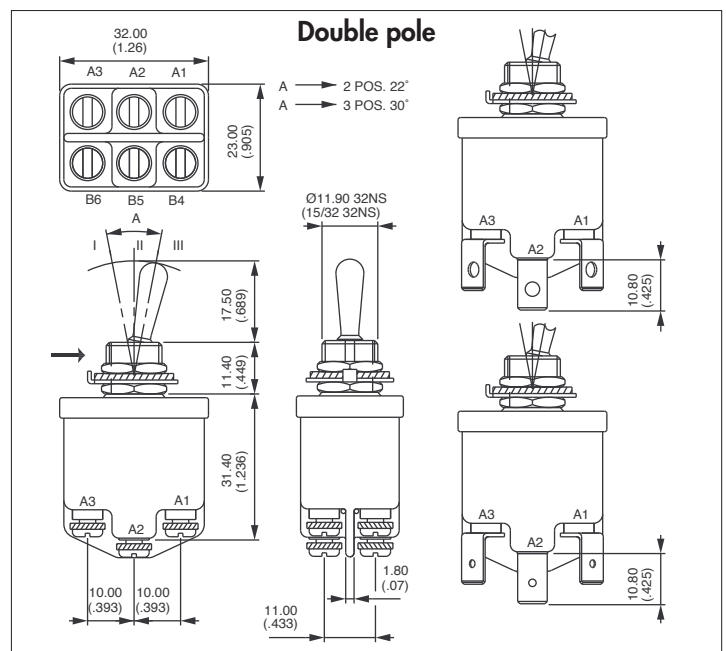
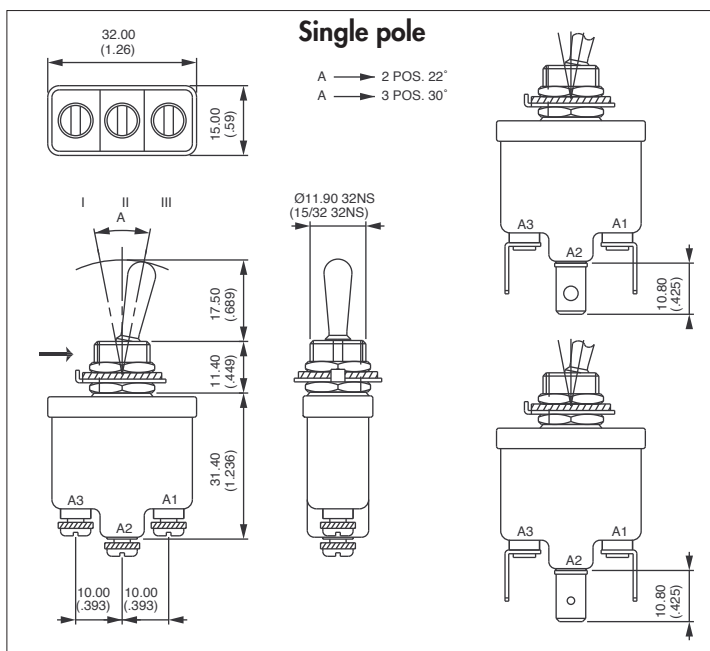

# CT series

## Sealed toggle switches

OPTIONS



### LEVER STYLES

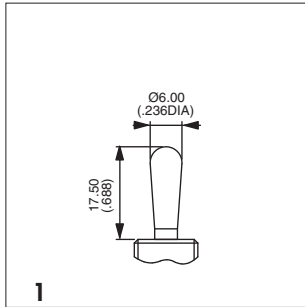
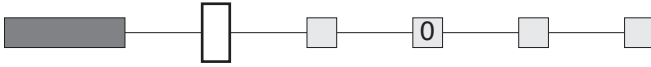

1

Standard

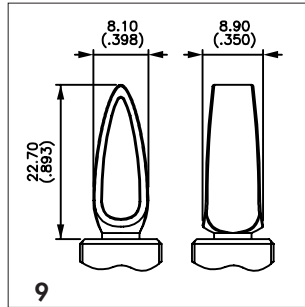

9

Plastic paddle

### LEVER FINISH

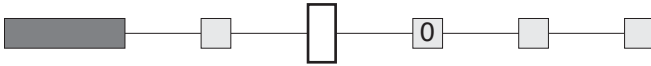

- N Bright nickel (for lever 1 only)  
4 Grey (for lever 9 only)

### LOCKING LEVER

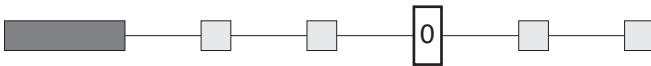

- 0 No locking

### AGENCY APPROVAL

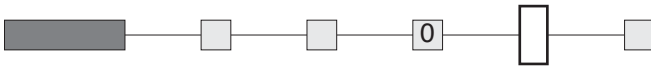

- 0 None  
2 UL

APEM has the ability to develop custom configurations. Please contact us with your requirements.



ERMEC, S.L. BARCELONA  
C/ Francesc Teixidó, 22  
08918 Badalona  
(España)

Tel.: (+34) 902 450 160  
Fax: (+34) 902 433 088  
[info@ermec.com](mailto:info@ermec.com)  
[www.ermec.com](http://www.ermec.com)

ERMEC, S.L. MADRID  
c/Mejorada, 17, 1ª Pla.Of.D4  
28850 Torrejón de Ardoz  
(España)

PORTUGAL  
[portugal@ermec.com](mailto:portugal@ermec.com)

BILBAO  
[bilbao@ermec.com](mailto:bilbao@ermec.com)  
Portugal  
[portugal@ermec.com](mailto:portugal@ermec.com)



ERMEC, S.L.  
(España)

Tel.: (+34) 902 450 160  
Fax: (+34) 902 433 088

[info@ermec.com](mailto:info@ermec.com)  
[www.ermec.com](http://www.ermec.com)



# CT series

## Sealed toggle switches

### MOUNTING ACCESSORIES

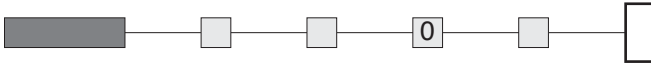

- 0** For NON-SEALED mounting (panel cut-out fig. 1, 2 or 3)  
2 hex nuts 14 mm (.551) across flats, 1 locking ring U121 or U12, 1 lockwasher U13  
Panel thickness : 5 mm (.196) max.
- 2** For SEALED mounting (panel cut-out fig. 2)  
2 hex nuts 14 mm (.551) across flats and 1 sealing washer U60  
Panel thickness : 4 mm (.157) max.

**Special hardware** : black cap nut U129. Order separately.

