

IP Desktop

Professional USB desktop controllers

Distinctive features and specifications



- ❑ 3 axis joysticks for PTZ control
- ❑ USB 1.1 HID compliant “game controller”
- ❑ Programmable pushbutton switches
- ❑ Easy to use and operate

- Joystick performance:
 - Hall effect three axis joystick
 - X/Y/Z for positioning control
- Joystick travel:
 - 36° for X and Y axis
 - 60° for Z axis
- Centering: Single spring, omni-directional
- Joystick shaft: Stainless steel
- Joystick boot: Neoprene
- Joystick handle: Glass filled nylon
- Pushbutton performance:
 - 10 tactile pushbuttons on housing
 - Two tactile pushbuttons on joystick
 - 3,000,000 cycles
- Desktop: High impact ABS housing
- Power:
 - Via USB interface (5V DC)
 - Consumption 32mA
- Operating conditions:
 - -25°C to +85°C (-13°F to +185°F)

- Approvals
 - EN 55024:1998, EN 55022, CE
 - FCC Part 15 Subpart B Class B
 - RoHs compliant
- Weight: 440 g (0.97lb)
- Interface: USB port
- Connectors
 - USB Type A Male
 - Cable Length: 2m; 6ft. 6.8in
- Systems support integration: Windows 7, Vista, XP, 2000, Window 8, OSX, Linux
- Supported protocols:
 - USB HID 1.1 game controller
 - Direct X (Gaming Control)
 - Joystick: Three HID axes
 - Pushbuttons: 12 HID buttons
 - Uses standard DirectX HID drivers
 - Connects directly to workstation PC
- Environmental: For indoor use only

NOTE: All values are nominal.

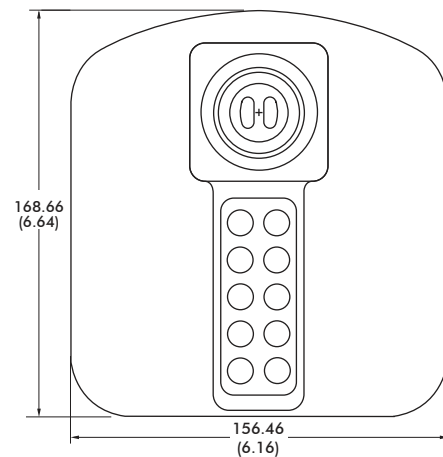
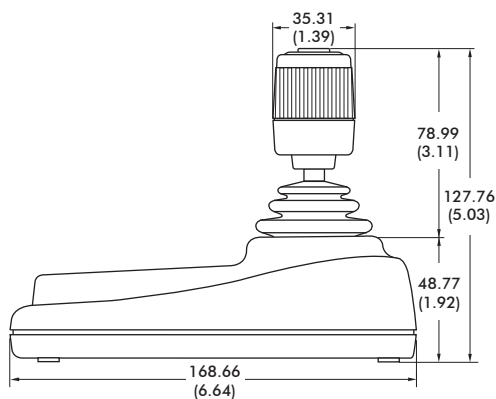

NOTES:

Dimensions are in mm/(inch).

To order the IP Desktop please refer to Part Number 100-550 (Gray or Black).