

XT

shroud, que se puede eliminar



XT

Characteristics ■ 8 mm contact gap 8 mm creepage and clearance distances
■ forced double break contacts

Rating 400 VAC, 16,5 A max.

Dimensions (mm) 30 × 32 × 12

Actuator ■ shrouded plunger
■ optional key
■ plain plunger

Approvals UL, cUL, CSA, ENEC

Preferred Range

Ordering Reference	Actuating Force (N) (ozf)	Operating pos. (mm) (in)	Terminal	Circuit	Actuator	Contacts	Electrical rating
XTD22AZ1	3,8 13,6	13,0 0,511	Faston	NO	Plunger	Ag nickel	Up to 400 VAC, 16,5 A

Specifications

Housing	Glass fibre reinforced polyester
Plunger	Glass fibre reinforced polyester
Mechanism	Normally open
Contacts	Silver nickel
Terminals	6.3 mm (0.25 in) faston - brass
Temperature range °C	-20°C to +85°C
Mechanical life	10 ⁶ cycles minimum (impact free actuation)
Protection	IP40 (enclosure)
Mounting	Snap-on or screw mounting
Actuator	Plunger (can be held depressed for maintenance with optional key shrouded option only)
Accessories	Maintenance key N41784 and multiplug housing XTMHSG

Circuit diagram

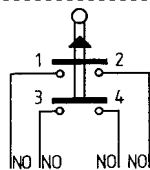

Dimensions

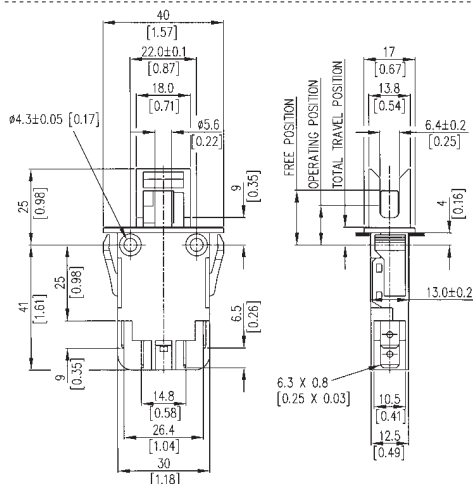

SNAP MOUNTING DETAILS

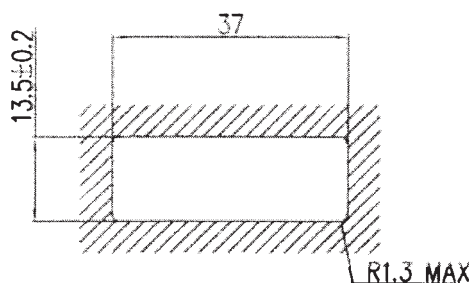

PANEL THICKNESS 1.0 – 2.5

Recommended maximum electrical ratings

Voltage (max)	Load (A)	Inductive load	Horsepower	Approval
125 VAC	15.5 (0.75 pf)	-	-	UL 1054/CSA 22.2 No. 55 - 100,000 operations
250 VAC	15.5 (0.75 pf)	-	-	UL 1054/CSA 22.2 No. 55 - 100,000 operations
125 VAC	-	-	½ HP (0.45 pf)	UL 1054 - Horsepower- 100,000 operations
250 VAC	-	-	½ HP (0.45 pf)	UL 1054 - Horsepower- 100,000 operations
125 VAC	-	-	1½ HP (0.45 pf)	UL 1054 - Horsepower- 100,000 operations
250 VAC	-	-	1½ HP (0.45 pf)	UL 1054 - Horsepower- 100,000 operations
30 VAC	0,5	-	-	EN.60158-1 T85 (°C) 50,0000 operations
400 VAC	16,5	8	-	EN.60158-1 T85 (°C) 50,0000 operations
30 VDC	0,5	-	-	UL 1054/CSA 22.2 No. 55 - 6,000 operations

Operating Characteristics

Actuator	Reference	Actuating Force Maximum		Release Force Minimum		Free Position Maximum		Operating Position		Total Travel Position Maximum		Over travel	
		(N)	(ozf)	(N)	(ozf)	(mm)	(in)	(mm)	(in)	(mm)	(in)	(mm)	(in)
Plunger	XTD22AZ1	3,8 (± 0.5)	13,600 (± 3.5)	5,8	20,8	18,0	0,708	13,0 ± 0.4 0,511 ± 0.016 (main contact)		10,0	0,394	3,0	0,118
								12,6 0,496 (low voltage contact)					

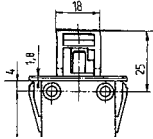

Ordering Reference

Basic type	XTD	Example: XTD	22	J	Z1
Terminals	22	6.3 × 0.8 mm faston terminals			
	A	100 k operations at 15:5 A 250 VAC, UL114 478			
Form	-	Without identification: snap-on mounting with shroud			
	J	Snap-on mounting without shroud			
	P	Without shroud, without snap-on mounting			
	K				
Approvals	Z1	UL, cUL, CSA and ENEC			



ERMEC, S.L. BARCELONA
C/ Francesc Teixidó, 22
08918 Badalona
(España)

Tel.: (+34) 902 450 160
Fax: (+34) 902 433 088
info@ermec.com
www.ermec.com

ERMEC, S.L. MADRID
c/Mejorada, 17,1ªPl. Of.D4
28850 Torrejón de Ardoz
(España)

PORTUGAL
portugal@ermec.com
BILBAO
bilbao@ermec.com