

SIF 3 Series



Relay Key Data

- PCB relay with forcibly guided contacts
- Protective separation between coil and contacts (> 5,5mm) and contacts side by side (> 5,5mm)
- IEC 61810-3 Type A
- Double and reinforced insulation between the contacts
- SMD placement under relay possible
- Contact mounting SIF212 2 NO / 1 NC
- Small overall height: Only 10,9 mm
- Nominal coil power 0,60 W
- Holding coil power 0,18 W
- Coils for railway applications according to EN 50 155 on request

Dimensions

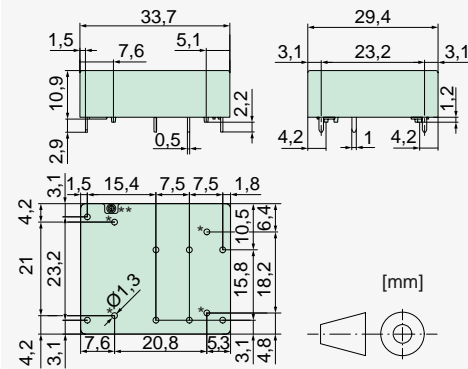

* do not drill with SMD assembly under the relay

** Open breathing hole

Contact Data

Contact material	AgCuNi + 0,2 µm Au
Type of contact	Single contact with notched crown
Rated switching capacity	250 VAC 10 A AC1 2500 VA
Electr. Life AC1(360 S / h)	approx. 100 000
Inrush current max.	30 A for 20 ms
Switching voltage range	5 to 250 VDC / VAC
Switching current range*	3 mA to 10 A
Switching capacity range*	40 mW to 2500 W(VA)
Contact resistance (as delivered)	≤100 mΩ / 6 V / 100 mA

*Guided values

Standard Coils for Direct Current

(other voltages on request)

Nominal voltage VDC	Min. pick-up voltage VDC at 20 °C	Drop-out voltage VDC at 20 °C	Nominal current in mA at 20 °C	Resistance in Ohm at 20 °C
5	≤3,5	≥0,5	120,0	41,6 ± 10%
12	≤8,4	≥1,2	50,0	240,0 ± 10%
18	≤12,6	≥1,8	33,3	540,0 ± 10%
20	≤14,0	≥2,0	30,0	665,0 ± 10%
24	≤16,8	≥2,4	25,0	960,0 ± 10%
48	≤33,6	≥4,8	12,5	3840,0 ± 10%
60	≤42,0	≥6,0	10,0	6000,0 ± 13%
110	≤77,0	≥11,0	5,4	20165,0 ± 15%

Circuit Diagram (relay top view)

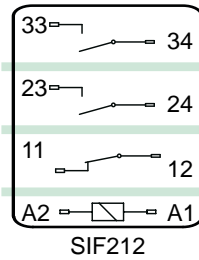

Insulation Data

- Double or reinforced insulation	at 250 VAC
- Air and creepage distance	>5,5 mm
- Test voltage	4000 V / 50 Hz / 1 min
Test voltage contact open	1500 V / 50 Hz / 1 min
Creepage resistance	CTI 175
Pollution degree	2
Overvoltage category	III
Insulation resistance at Up 500 VDC	>100 MΩ

Additional Data

Mechanical endurance	>10 x 10 ⁶ operations
Switching frequency, mechanical	15 Hz
Response time (all NO closed)	typically 12 ms
Drop-out time (NC closed)	typically 5 ms
Bounce time of NO contact	typically 1,5 ms
Bounce time of NC contact	typically 15 ms
Shock resistance 16 ms	NO > 15g NC > 6g
Vibration resistance (10-200 Hz)	NO > 10g NC > 2g
Resistance to short circuiting contacts NO	1000 A SCPD 10 A gG / gL (pre-fuse)
Resistance to short circuiting contacts NC	1000 A SCPD 6 A gG / gL (pre-fuse)
Ambient temperature	-40°C to +70°C
Thermal Resistance	60 K / W
Temperature limit for coil	120°C
Weight	approx. 18 g
Mounting position	any
Mounting distance	rec. >5 mm
Test method	A / group assembly
Type of protection	RT II
Solder bath temperature	270°C / 5 s

**without spark suppression

Tests, Regulations, Standards

Approvals	
UL File E188953	Sec. 6
Insulation class IEC 60664-1	250 VAC
Fire protection requirements	UL 94 / V0
Standards IEC 61810-1, IEC 61810-3	

Options, Accessories

none available

Product Key

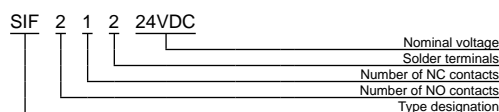

Contact Lifetime for NO Contacts

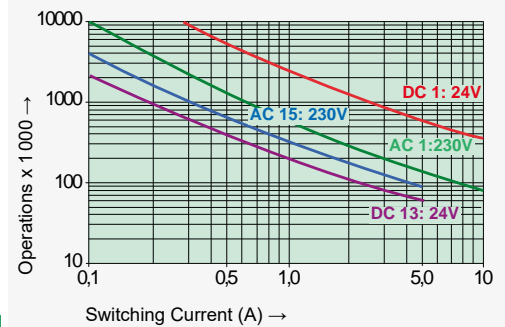

Maximal switching characteristics (EN60947-5-1)

AC 1:	250 V / 10 A
AC 15:	230 V / 5 A
DC 1:	24 V / 10 A
DC 13:	24 V / 5 A / 0,1 Hz
UL 508:	B300 / R300

Maximal contact load at AC 1 with 230 V:
2 contacts with 8 A each

Load Limit Curve with Direct Current

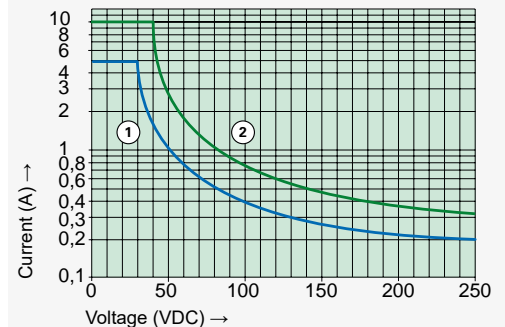

- 1) Inductive load L/R 40 ms
- 2) Resistive load

Excitation Voltage Range

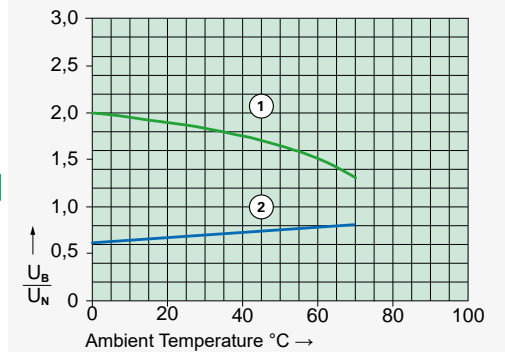

- 1) Max. excitation voltage with contact load: ≤6 A
- 2) Min. excitation voltage (guaranteed values) without previous operation

Single relay on print, no heat accumulation due to surrounding components with self-heating, duty cycle 100%.