

Relays SIM 4 series



Features

- Relay with forcibly guided contacts according to IEC 61810-3, application type A
- Suitable for print mounting
- Protective separation (see insulation data)
- Contact mounting:
SIM312 3 NO + 1 NC
SIM222 2 NO + 2 NC
- Small outer dimensions
- Nominal coil power: typ. 1 W
- Coil holding power: typ. 0,29 W

Dimensions

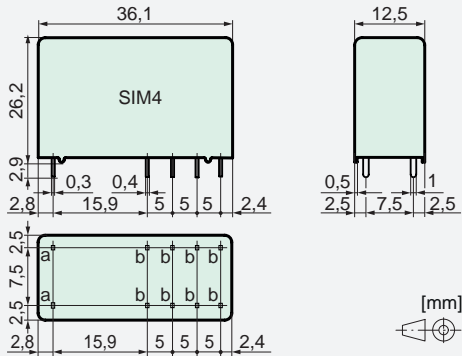

Pin dimension a	1,0 x 0,3 mm
Pin dimension b	1,0 x 0,4 mm
Recommended drilling on PCB	Ø 1,3 mm

Contact data

Contact material	AgSnO ₂ + 0,2 ... 0,4 µm Au
Contact type	crown contact
Nominal switching capacity AC-1	2000 VA (250 VAC / 8 A)
Electrical life AC-1 (0,1 Hz, 10% duty cycle)	approx. 100000
Inrush current max.	20 A for 20 ms
Switching voltage range	5 ... 250 VDC/VAC
Switching current range*	10 mA ... 8 A
Switching power range*	60 mW ... 2000 W(VA)
Contact resistance as new	≤100 mΩ / 6 V / 100 mA

*guidelines

Coil data at 20 °C

Nominal voltage (VDC)	Pick-up voltage (VDC)	Drop-out voltage (VDC)	Nominal current (mA)	Resistance (Ohm)
6	≤4,2	≥0,6	167	36 ± 10%
12	≤8,4	≥1,2	86	140 ± 10%
18	≤12,6	≥1,8	55	330 ± 10%
24	≤16,8	≥2,4	40	600 ± 10%
48	≤33,6	≥4,8	21	2300 ± 10%
60	≤42,0	≥6,0	17	3600 ± 13%
110	≤77,0	≥11,0	9	12100 ± 15%

other voltage values on request

Circuit diagram (top view)

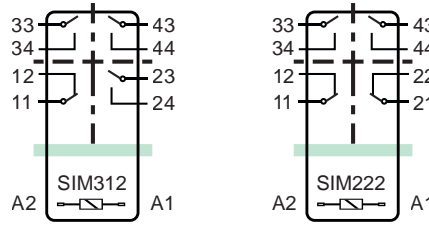

Insulation data

Basic insulation	at 250 VAC
Air and creepage distance	>4 mm
Test voltage	2500 V _{rms} / 1 min
Double or reinforced insulation	at 250 VAC
Air and creepage distance	>5,5 mm
Test voltage	4000 V _{rms} / 1 min
Double or reinforced insulation	at 250 VAC
Air and creepage distance	>14 mm
Test voltage	5000 V _{rms} / 1 min
Test voltage: open contact	1500 V _{rms} / 1 min
Creepage resistance	CTI 175
Pollution degree	2
Overvoltage category	III
Insulation resistance at U _p 500 VDC	>100 MΩ

Additional data

Mechanical lifetime	> 10x10 ⁶ operations
Switching frequency mechanical	max. 15 Hz
Response time (NO closed)	typ. 8 ms
Drop-out time* (NC closed)	typ. 4 ms
Bounce time NO	typ. 6 ms
Bounce time NO	typ. 12 ms
Shock resistance (16 ms)	NO > 10 g / NC > 2,5 g
Vibration resistance (10-200 Hz)	NO > 10 g / NC > 1 g
Short circuit resistance of contacts	1000 A
with pre-fuse	SCPD 10 A gG / gL
Ambient temperature	-40 °C ... +70 °C
Thermal resistance	50 K/W
Coil limit temperature	120 °C
Weight	approx. 25 g
Mounting position	any
Mounting distance	recommendation >5 mm
Test method	A / group assembly
Protection class	RT II
Solder bath temperature	270 °C / 5 s

*without coil wiring

Tests, regulations, standards

Approvals	cULus, TÜV
UL File	E188953 Sec. 3
Insulation group according to IEC 60664-1	250 VAC
Fire protection conditions	UL 94 / V-0
Standards	IEC 61810-1, IEC 61810-3, UL 508

Options, Accessories

Mounting rail socket	SRD-SIM4
PCB socket	SRP-SIM4

Product key

SIM	3	1	2	24VDC
Type designation	Number of NO contacts	Number of NC contacts	Solder terminals	Nominal coil voltage

Contact life for NO contact

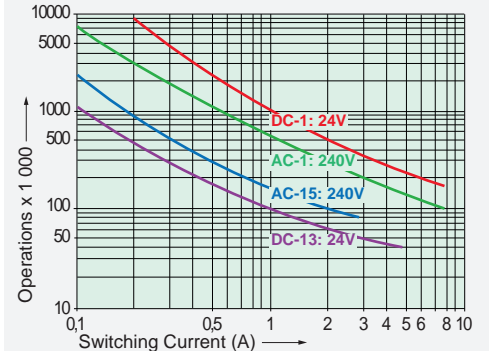

Max. switching capacity (IEC 61810-1, UL 508)

AC-1:	240 V / 8 A	C150
AC-15:	240 V / 3 A	R300
DC-1:	24 V / 8 A	
DC-13:	24 V / 6 A	

Maximum continuous current per contact at load of:

1 contact	8 A
2 contacts	8 A
3 contacts	6 A

Contact load limit curve (DC)

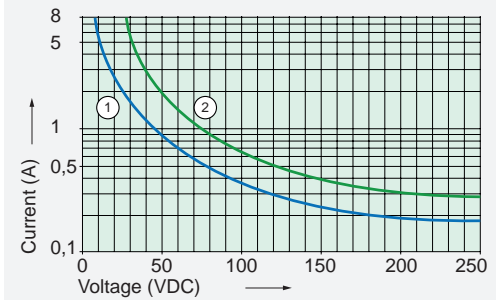

- 1) Inductive load L/R 40 ms
- 2) Resistive load

Coil excitation voltage range

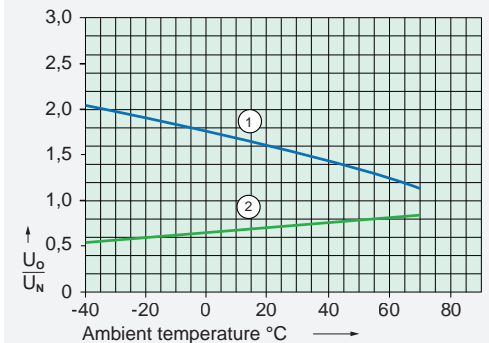

- 1) Max. excitation voltage with contact current ≤ 6 A
- 2) Min. excitation voltage without previous operation

- test conditions:

- Free-standing relay on PCB
- Duty cycle 100%