

# SIR 4 Series



## Relay Key Data

- PCB relay with forcibly guided contacts
- Protective separation between coil/control contact and output contacts (>10 mm), as well as output contacts against each other (>8 mm)
- IEC 61 810-3 Type A
- Contact mounting: SIR312 3 NO / 1 NC  
SIR222 2 NO / 2 NC
- Small external dimensions
- Nominal coil power 0,6 W
- Holding coil power 0,18 W
- Coil for railway application according EN 50 155 on request

## Dimensions

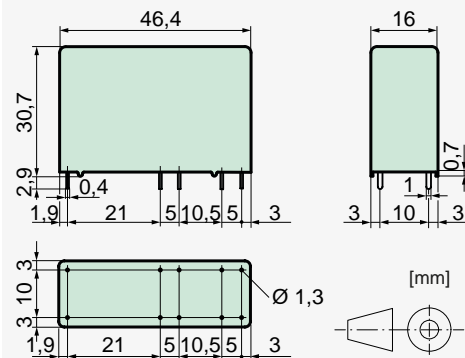

## Contact Data

Contact material	AgSnO <sub>2</sub> + 0,2 µm Au
Type of contact	crown contact
Rated switching capacity	250 VAC 10 A AC1 2500 VA
Electr. Life AC1(360 S / h)	approx. 100000
Inrush current max.	25 A for 20 ms
Switching voltage range	5 to 250 VDC / VAC
Switching current range*	10 mA to 10 A
Switching capacity range*	60 mW to 2500 W(VA)
Contact resistance (as delivered)	≤100 mΩ / 6 V / 100 mA

\*Guided values

## Standard Coils for Direct Current

(other voltages on request)

Nominal voltage VDC	Min. pick-up voltage VDC at 20 °C	Drop-out voltage VDC at 20 °C	Nominal current in mA at 20 °C	Resistance in Ohm at 20 °C
5	3,5	≥0,5	121,0	41 ± 10%
6	4,2	≥0,6	100,0	60 ± 10%
12	8,4	≥1,2	50,0	240 ± 10%
18	12,6	≥1,8	33,3	540 ± 10%
24	16,8	≥2,4	25,2	950 ± 10%
48	33,6	≥4,8	12,6	3800 ± 10%
60	42,0	≥6,0	10,0	6000 ± 13%
110	77,0	≥11,0	5,5	20000 ± 15%

## Circuit Diagram (relay top view)

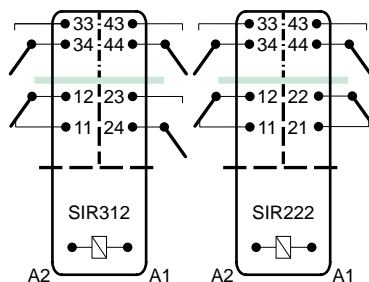

## Insulation Data

- Basic insulation	at 250 VAC
- Air and creepage distance	>4 mm
- Test voltage	2500 V / 50 Hz / 1 min
- Double or reinforced insulation	at 250 VAC
- Air and creepage distance	>8 mm
- Test voltage	4000 V / 50 Hz / 1 min
- Double or reinforced insulation	at 250 VAC
- Air and creepage distance	>10 mm
- Test voltage	5000 V / 50 Hz / 1 min
Test voltage contact open	1500 V / 50 Hz / 1 min
Creepage resistance	CTI 250
Pollution degree	2
Overvoltage category	III
Insulation resistance at Up 500 VDC	>100 MΩ

## Additional Data

Mechanical endurance	>10 x 10 <sup>6</sup> operations
Switching frequency, mechanical	15 Hz
Response time (all NO closed)	typically 15 ms
Drop-out time** (NC closed)	typically 4 ms
Bounce time of NO contact	typically 6 ms
Bounce time of NC contact	typically 12 ms
Shock resistance 16 ms	NO > 10g NC > 6g
Vibration resistance (10-200 Hz)	NO > 5g NC > 1,5g

Resistance to short circuiting contacts	1000 A SCPD 10 A gG / gL (pre-fuse)
Ambient temperature	-40°C to +70°C
Thermal Resistance	55 K / W
Temperature limit for coil	120°C
Weight	approx. 30 g
Mounting position	any
Mounting distance	rec. >5 mm
Test method	A / group assembly
Type of protection	RT II
Solder bath temperature	270°C / 5 s

\*\*without spark suppression

## Tests, Regulations, Standards

Approvals	
UL File E188953	Sec. 3
Insulation class IEC 60664-1	250 VAC
Fire protection requirements	UL 94 / V0
Standards IEC 61810-1, IEC 61810-3	

## Options, Accessories

Print socket

## Product Key

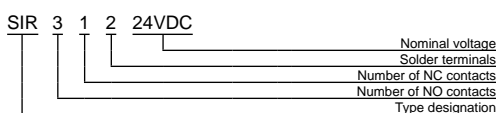

## Contact Lifetime NO Contacts

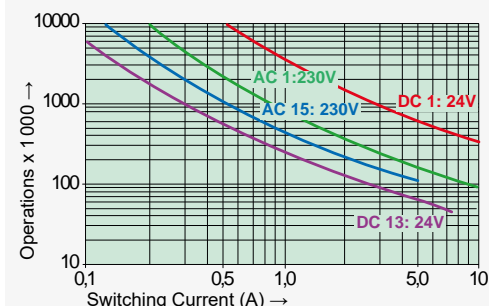

Maximal switching capacity (DIN EN 60947-5-1, Tab. C2)

AC 15:	230 V / 5 A
DC 13:	24 V / 7,5 A / 0,1 Hz
UL 508:	C600 / R300

Maximal contact load at AC 1 with 230 V:

- 2 contacts with 10 A each
- 3 contacts with 8,4 A each

## Load Limit Curve with Direct Current

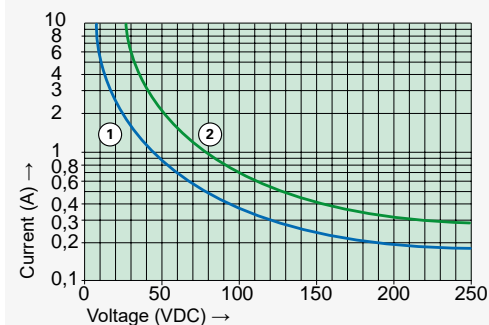

- 1) Inductive load L/R 40 ms
- 2) Resistive load

## Excitation Voltage Range

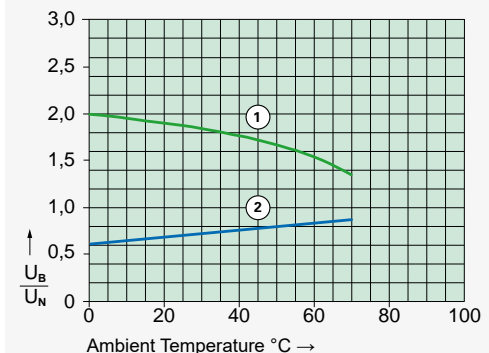

- 1) Max. excitation voltage with contact load: ≤6 A
- 2) Min. excitation voltage (guaranteed values) without previous operation

Single relay on print, no heat accumulation due to surrounding components with self-heating, duty cycle 100%.