

UAL

UAL 1/5; UAL 2

Dimensions (mm)	20 x 30
Travel (mm)	15
Travel per step (mm)	0.021/0.033
Thread pitch (mm)	0.5/0.8
Speed (mm/s) at 200 Hz	4.16/6.66
Step angle (°)	15
Max. Force (N)*	40



*Depends on winding, frequency and lifetime required.

Limited application of the motor driving against end stop is available under required technical and operating conditions. JE will provide specifics of such conditions upon request. JE will not be responsible for product warranty or any liabilities associated with the application of drive against end stop if such application is used without following JE's instructions.

Radial forces on the shaft will reduce life time and performance.

Note: All force and power output values are minimum values, at rated voltage and motor temperature 23°C.

Standard Data

Climatic class	wide-spread according to DIN IEC 60721-2-1 : 2015
Ambient temperature operation	°C -15 ... +60
Ambient temperature storage	°C -20 ... +100
Thermal resistance at f=0 R _{them}	47 K/W
Thermal class	130 (B) according to DIN EN 60085 : 2008
Approval	standard
Mounting	any position
Electrical connection	lead wire with CT connector
Protection	IP40 according to DIN EN 60529 : 2014
Weight	33 g
Rotor stalling	motor can be stopped when voltage is applied, without being overheated
Bearings	ball bearing

Order Reference

Type	Stepper Motor	UAL	1E	N	01	E	1A
Configuration	1A bipolar, standard magnet, screw flange 1E bipolar, standard magnet, bayonet flange 2A unipolar, standard magnet, screw flange 2E unipolar, standard magnet, bayonet flange 5A bipolar, stronger magnet, screw flange 5E bipolar, stronger magnet, bayonet flange						
Approval	N standard						
Winding code	see next page, resistance per winding for bipolar or unipolar						
Connection	E 100 mm lead wire with CT connector						
Shaft	1A Travel 15 mm ± 0.7 mm (others on request)						

All specifications are representative only and maybe subject to variation. For confirmation of values, please contact Johnson Electric.
Please also read "Saia Motors Important Notes" on catalog or at www.johnsonelectric.com/SaiaMotorsNotes



Technical Data

Steps per mm		48
Winding temperature T_{max}	°C	130
Linear travel max.	mm	15
Axial play at 20 N force	mm	0.25

unipolar versions available upon request

bipolar	Rated voltage U_N	V	6	12	24
	Duty cycle	%	100	100	100
	Resistance R_{20}	Ω	40	150	610
	Winding code		03	01	04

* measured at 23 °C, lifetime depends on load characteristics and ambient conditions

Circuit diagram bipolar

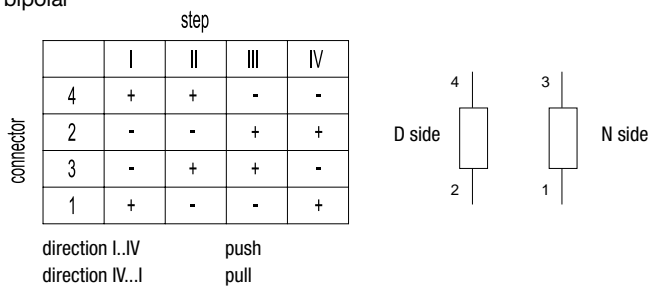

unipolar

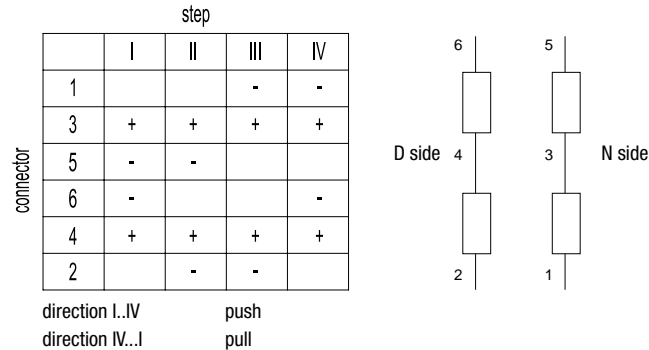

Dimensions Version with 100 mm leads and CT connector, 15 mm travel

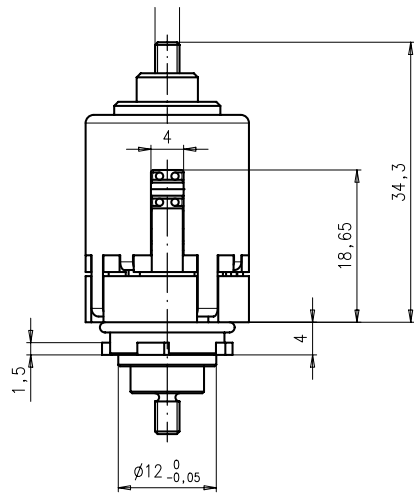
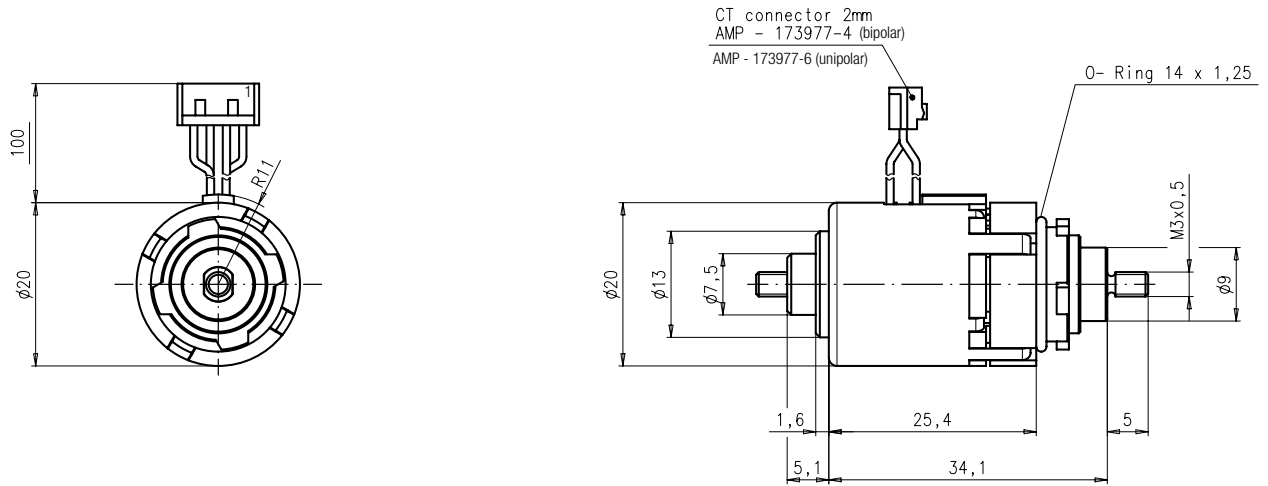

Connecting dimensions of direct bayonet mount

Material thickness 1.5 mm

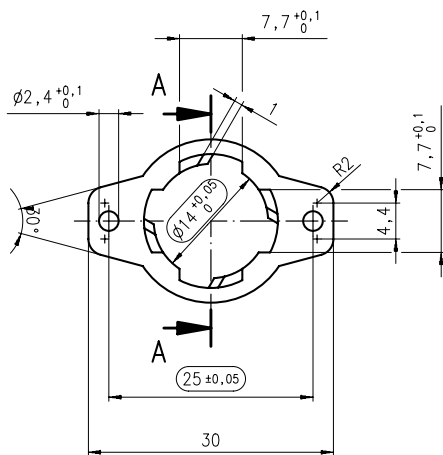
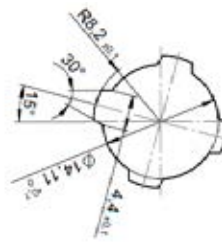

Performance Chart

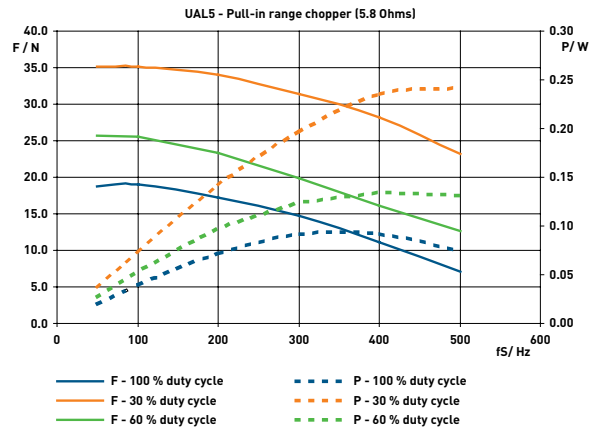
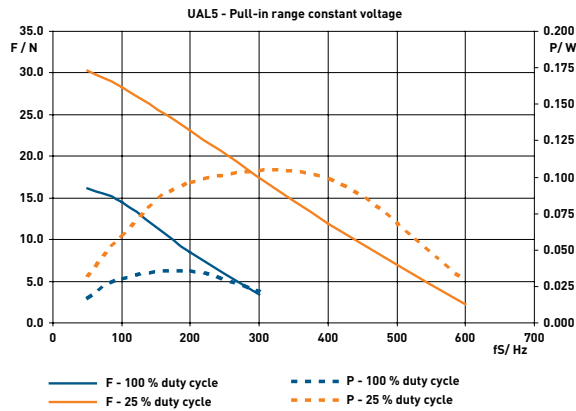
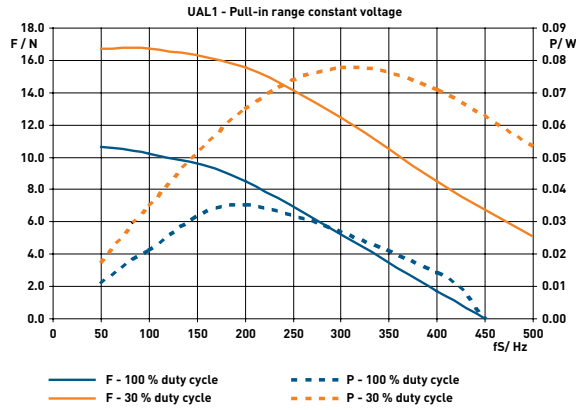

100% duty cycle: max. current per phase 300 mA
 60% duty cycle: max. current per phase 360 mA
 30% duty cycle: max. current per phase 500 mA

UCE

UCE1/7; UCE2/8

Dimensions (mm) Ø 28 x 31

Travel (mm) 10/13

Travel per step (mm) 0.021

Speed (mm/s) 4.16
at 200 Hz

Max. Force (N)* 80



*Depends on winding, frequency and lifetime required.

Limited application of the motor driving against end stop is available under required technical and operating conditions. JE will provide specifics of such conditions upon request. JE will not be responsible for product warranty or any liabilities associated with the application of drive against end stop if such application is used without following JE's instructions.

Radial forces on the shaft will reduce life time and performance.

Note: All force and power output values are minimum values, at rated voltage and motor temperature 23°C.

Standard Data

Climatic class	wide-spread according to DIN IEC 60721-2-1 : 2015
Ambient temperature operation	°C -15 ... +60
Ambient temperature storage	°C -20 ... +100
Thermal resistance at f=0 R _{therm}	29 K/W
Thermal class	130 (B) according to DIN EN 60085 : 2008
Approval	standard
Mounting	any position
Electrical connection	connector type B, C, D
Protection	IP40 according to DIN EN 60529 : 2014
Weight	67 g
Rotor stalling	motor can be stopped when voltage is applied, without being overheated
Bearings	ball bearing

Order Reference

Type	Stepper Motor				UCE	13	N	01	D	1E
Configuration	13	bipolar, standard magnet	73	bipolar, stronger magnet						
	23	unipolar, standard magnet	83	unipolar, stronger magnet						
Approval	N									
Resistance	see next page, Resistance per winding for bipolar or unipolar									
Connection	B, C see next pages "Connection Types" D									
Shaft	1E Travel 13 mm ± 0.7 mm (other standard shafts see under dimensions)									

All specifications are representative only and maybe subject to variation. For confirmation of values, please contact Johnson Electric.
Please also read "Saia Motors Important Notes" on catalog or at www.johnsonelectric.com/SaiaMotorsNotes



Technical Data

bipolar	Rated voltage U_N :	V	6	12	24
	Duty cycle	%	100	100	100
	Resistance R_{20}	Ω	24	90	380
	Winding code		05	02	01
unipolar	Rated voltage U_N :	V	6	12	24
	Duty cycle	%	100	100	100
	Resistance R_{20}	Ω	24	90	380
	Winding code		07	08	01
	Travel per step	mm	0.042		
	Winding temperature T_{max}	$^{\circ}C$	130		
	Axial play at ± 20 N force	mm	< 0.25		

Circuit diagram bipolar

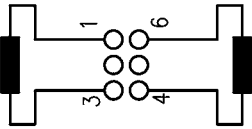

stepping sequence number

	I	II	III	IV	I
pin 1	+	+	-	-	+
pin 3	-	-	+	+	-
pin 4	-	+	+	-	-
pin 6	+	-	-	+	+

→ Pull in (step I to IV, I to IV, etc.)

← Push out (step IV to I, step IV to I, etc.)

unipolar

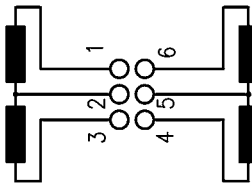

stepping sequence number

	I	II	III	IV	I
pin 1	-	-			-
pin 2	+	+	+	+	+
pin 3			-	-	
pin 4		-	-		
pin 5	+	+	+	+	+
pin 6	-			-	-

→ Pull in (step I to IV, I to IV, etc.)

← Push out (step IV to I, step IV to I, etc.)

Dimensions Version with Connector D, with 13 mm travel, shaft 1E

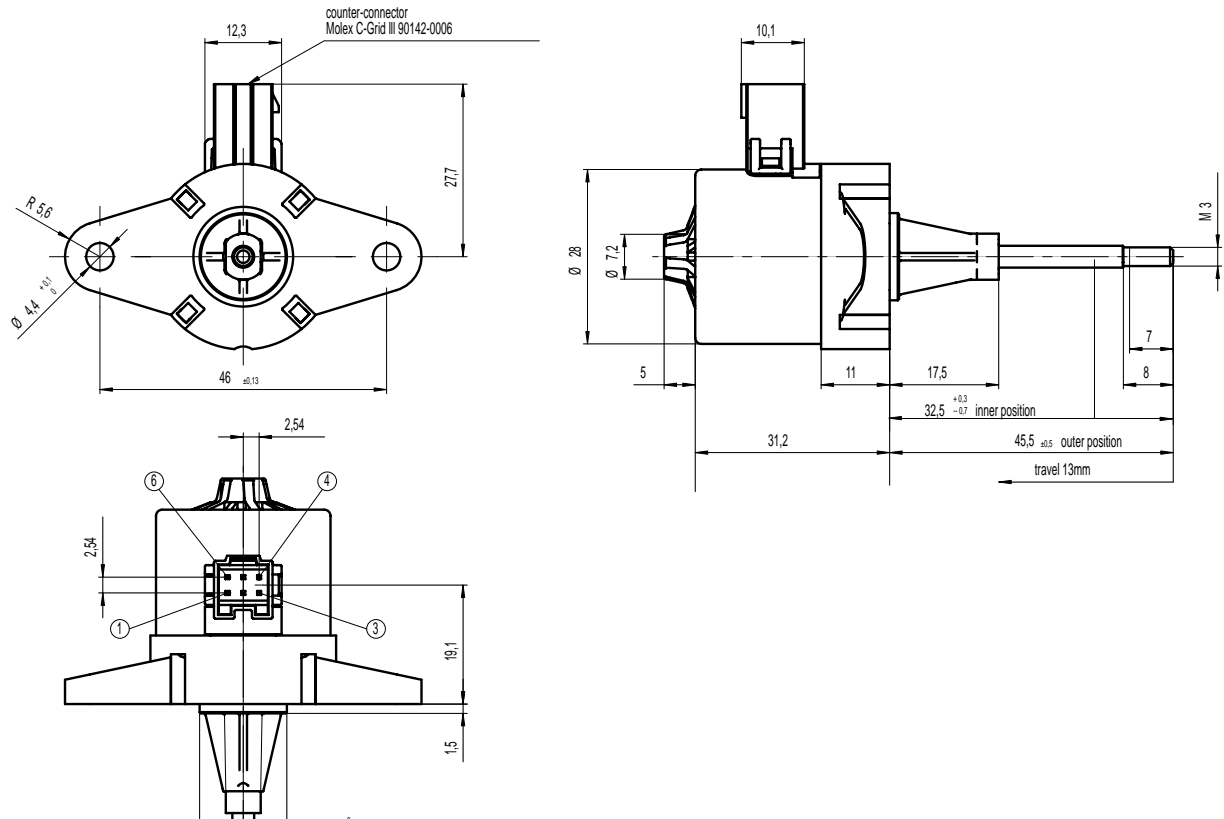

Version with Connector D, with 50..150 mm travel, shaft 1R, 1S, 1Q - only for pull operation

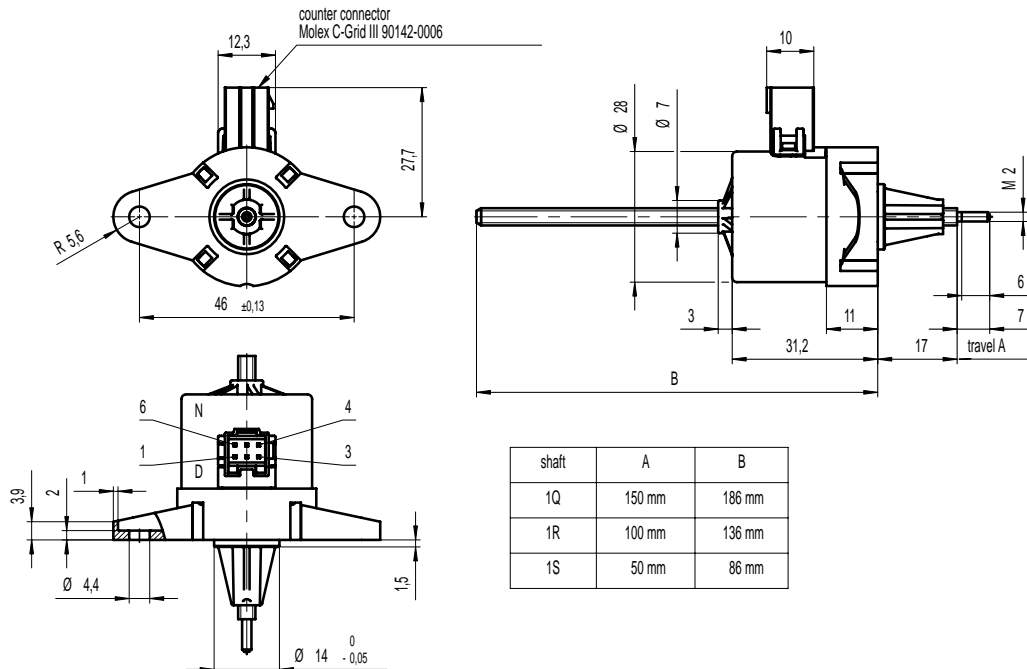

Please note:

The linear motor with non-captive shaft needs an external antirotation fixation and guidance. The antirotation is to produce the linear movement.

Application design of the guidance has to consider a maximum tolerance of 0.2° from the ideal axis.

The shaft guidance has strong influence on motor live time.

UCE

Performance Chart

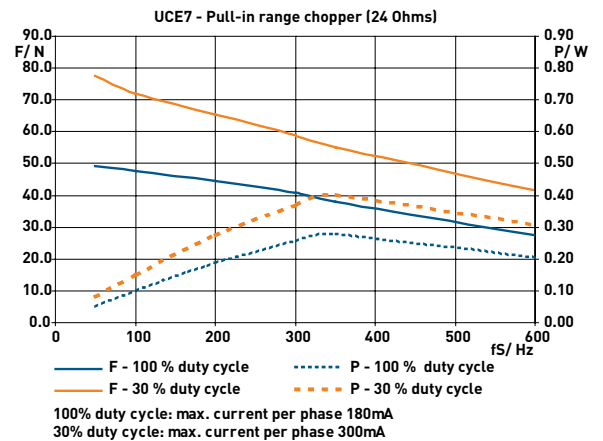
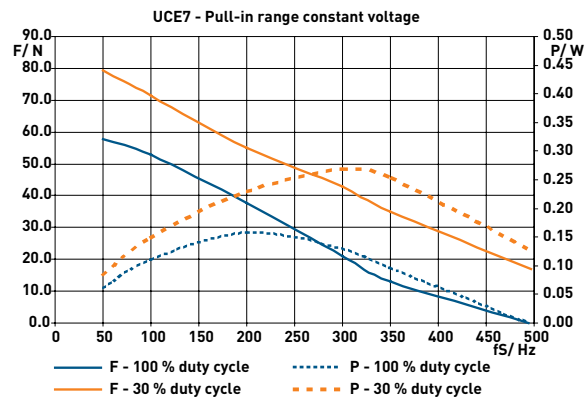
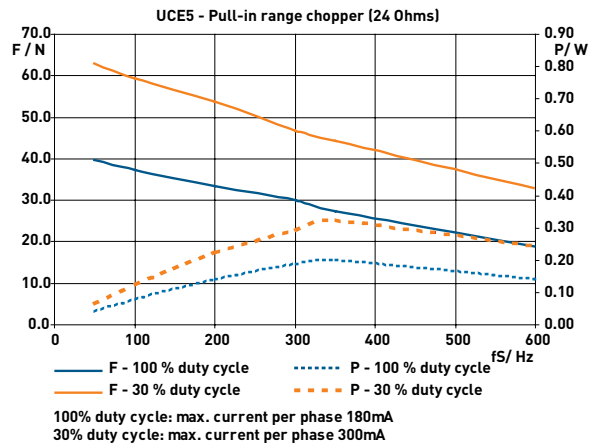
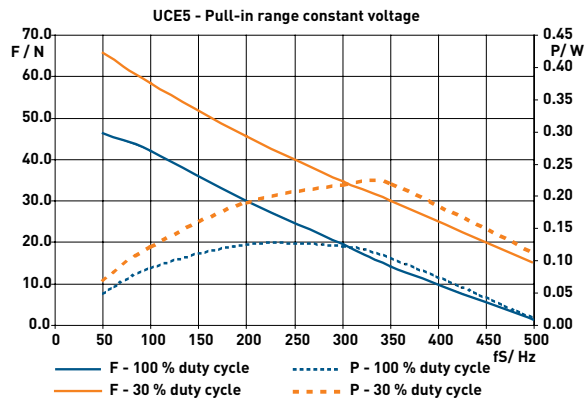
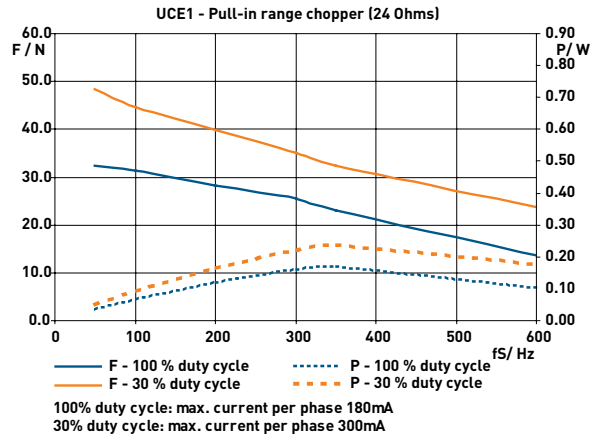
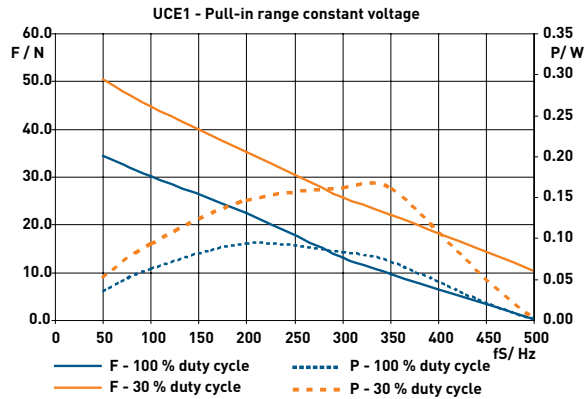

Performance Chart

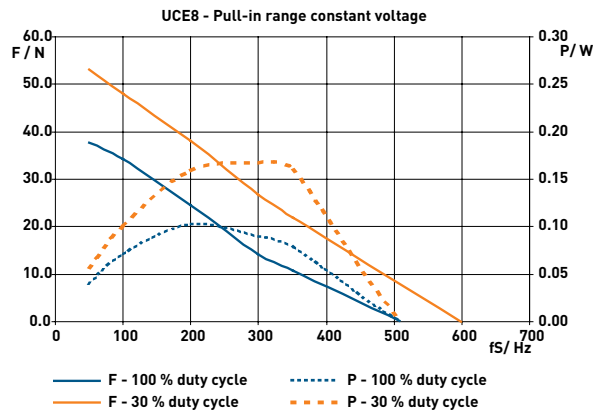
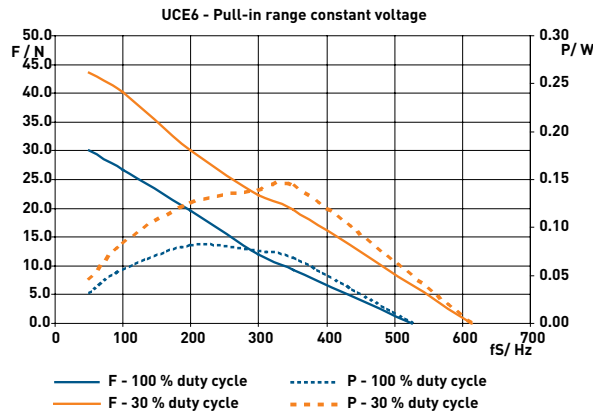
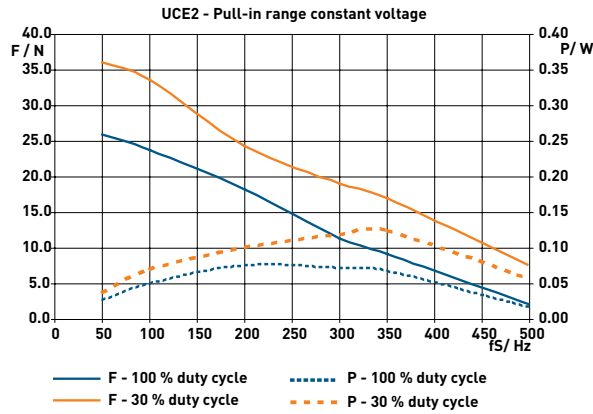

UCL

UCL1/7; UCL2/8

Dimensions (mm)	∅ 28 x 31
Travel (mm)	10/13
Travel per step (mm)	0.041
Speed (mm/s) at 200 Hz	8.33
Max. Force (N)*	70



*Depends on winding, frequency and lifetime required.

Limited application of the motor driving against end stop is available under required technical and operating conditions. JE will provide specifics of such conditions upon request. JE will not be responsible for product warranty or any liabilities associated with the application of drive against end stop if such application is used without following JE's instructions.

Radial forces on the shaft will reduce life time and performance.

Note: All force and power output values are minimum values, at rated voltage and motor temperature 23°C.

Standard Data

Climatic class	wide-spread according to DIN IEC 60721-2-1 : 2015
Ambient temperature operation	°C -15 ... +60
Ambient temperature storage	°C -20 ... +100
Thermal resistance at f=0 R _{therm}	29 K/W
Thermal class	130 (B) according to DIN EN 60085 : 2008
Approval	standard
Mounting	any position
Electrical connection	connector type B, C, D
Protection	IP40 according to DIN EN 60529 : 2014
Weight	67 g
Rotor stalling	motor can be stopped when voltage is applied, without being overheated
Bearings	ball bearing

Order Reference

Type	Stepper Motor				UCL	13	N	01	D	1E
Configuration	13	bipolar, standard magnet	73	bipolar, stronger magnet						
	23	unipolar, standard magnet	83	unipolar, stronger magnet						
Approval	N									
Resistance	see next page, Resistance per winding for bipolar or unipolar									
Connection	B, C see next pages „Connection Types“ D									
Shaft	1E Travel 13 mm ± 0.7 mm (other standard shafts see under dimensions)									



All specifications are representative only and maybe subject to variation. For confirmation of values, please contact Johnson Electric. Please also read "Saia Motors Important Notes" on catalog or at www.johnsonelectric.com/SaiaMotorsNotes

Technical Data

bipolar	Rated voltage U_N :	V	6	12	24
	Duty cycle	%	100	100	100
	Resistance R_{20}	Ω	24	90	380
	Winding code		05	02	01
unipolar	Rated voltage U_N :	V	6	12	24
	Duty cycle	%	100	100	100
	Resistance R_{20}	Ω	24	90	380
	Winding code		07	08	01
	Travel per step	mm	0.042		
	Winding temperature T_{max}	$^{\circ}C$	130		
	Axial play at ± 20 N force	mm	< 0.25		

Circuit diagram bipolar

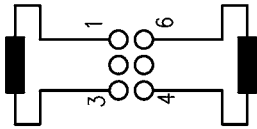

stepping sequence number

	I	II	III	IV	I
pin number 1	+	+	-	-	+
pin number 3	-	-	+	+	-
pin number 4	-	+	+	-	-
pin number 6	+	-	-	+	+

→ Pull in (step I to IV, I to IV, etc.)



← Push out (step IV to I, step IV to I, etc.)

unipolar

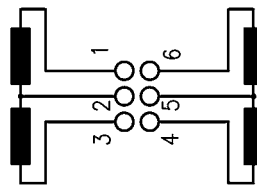

stepping sequence number

	I	II	III	IV	I
pin number 1	-	-			-
pin number 2	+	+	+	+	+
pin number 3			-	-	
pin number 4		-	-		
pin number 5	+	+	+	+	+
pin number 6	-			-	-



→ Pull in (step I to IV, I to IV, etc.)



← Push out (step IV to I, step IV to I, etc.)

Dimensions Version with Connector D, with 13 mm travel, shaft 1E

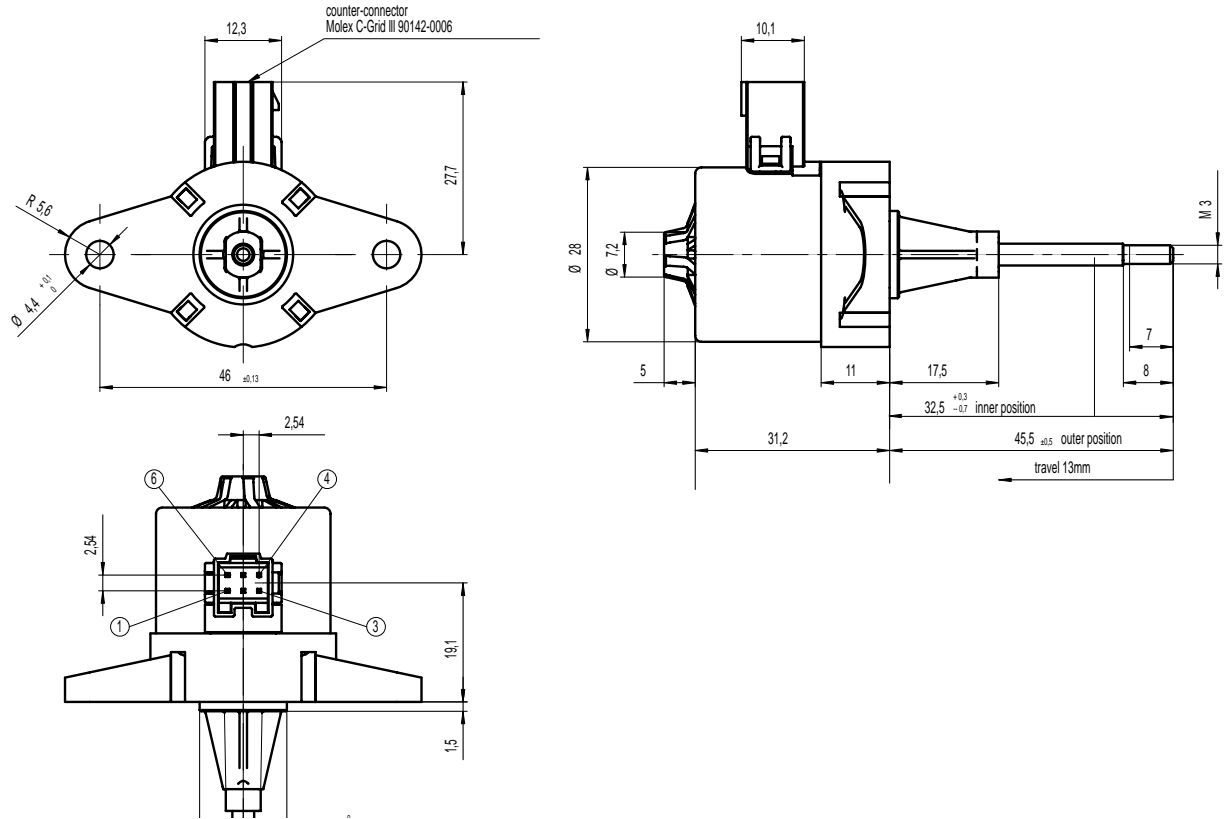

Version with Connector D, with 50..150 mm travel, shaft 1R, 1S, 1Q - only for pull operation

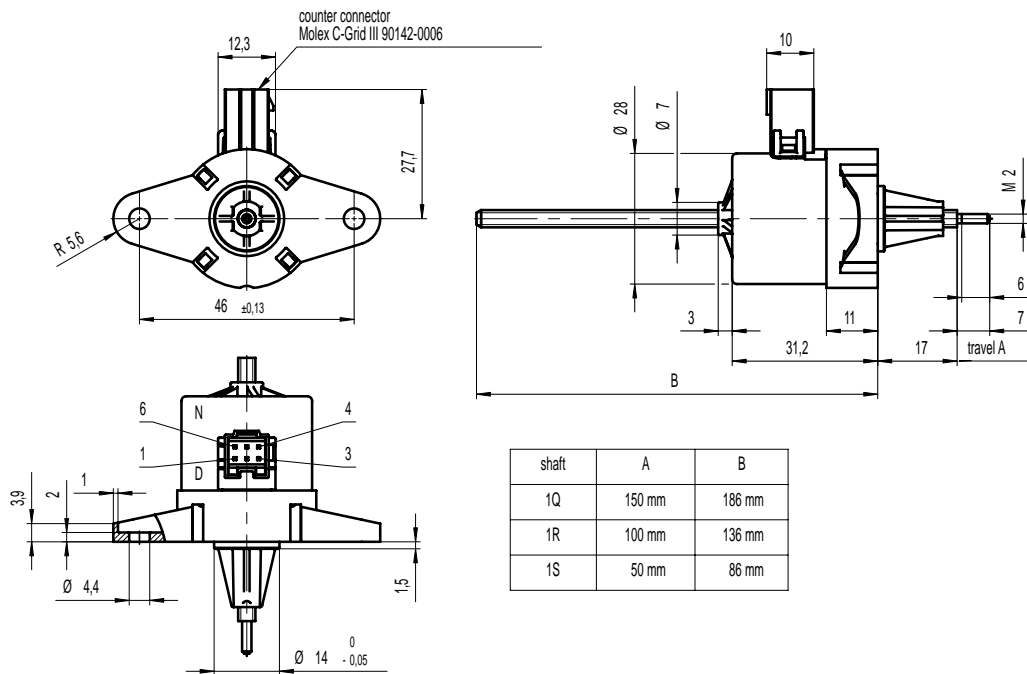

Please note:

The linear motor with non-captive shaft needs an external antirotation fixation and guidance. The antirotation is to produce the linear movement.

Application design of the guidance has to consider a maximum tolerance of 0.2° from the ideal axis.

The shaft guidance has strong influence on motor live time.

Performance Chart

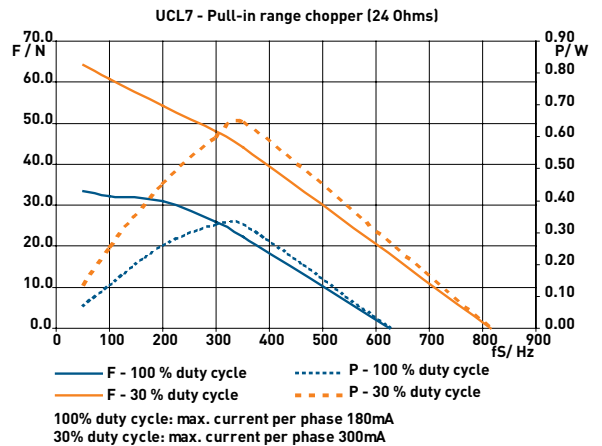
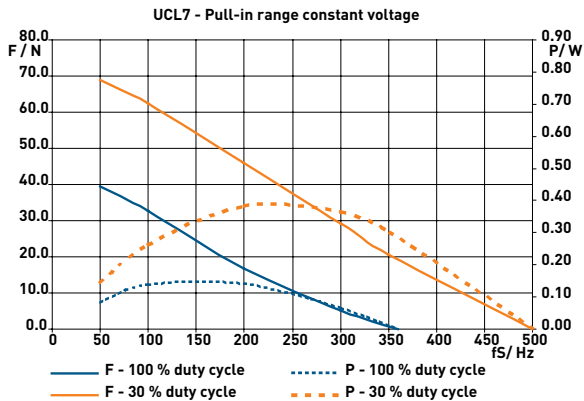
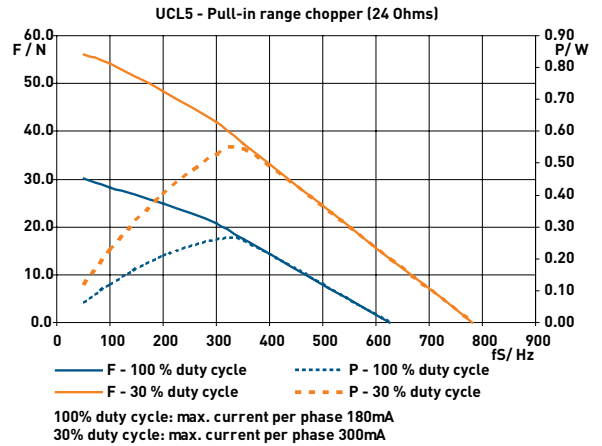
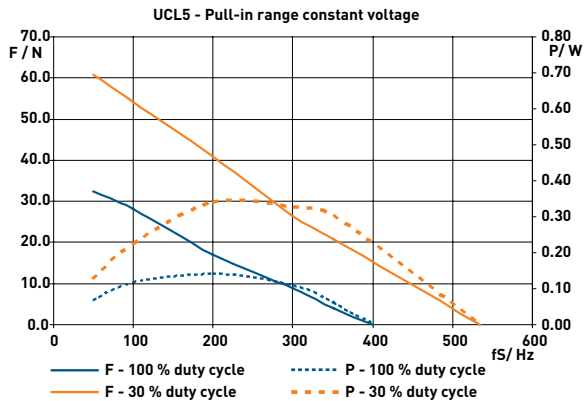
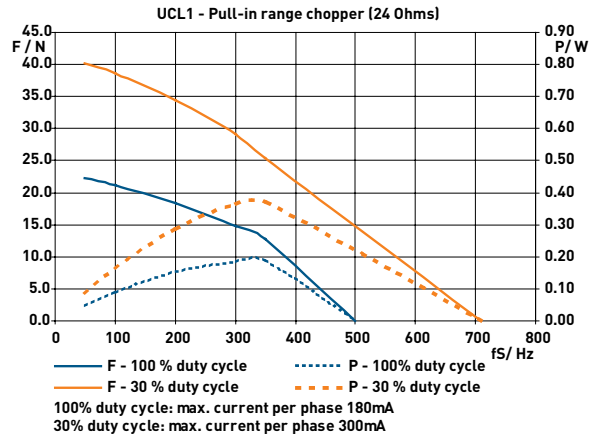
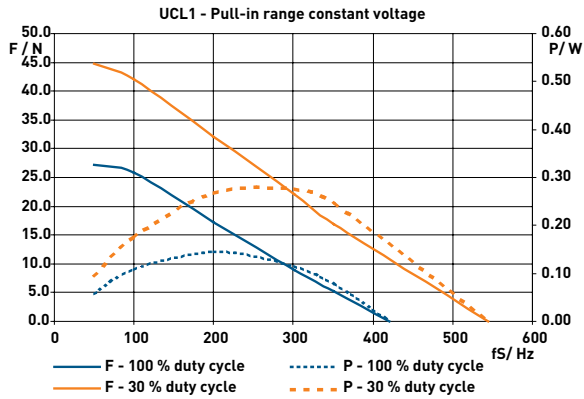

Linear

Performance Chart

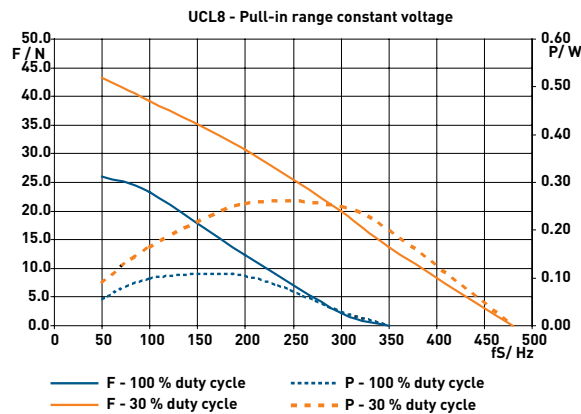
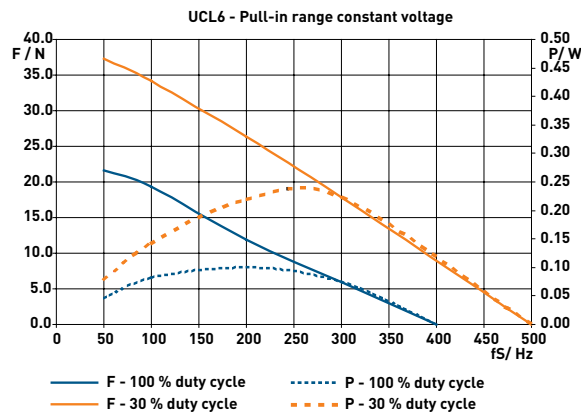
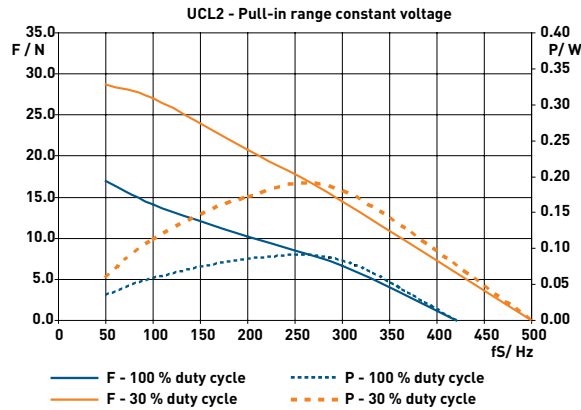

Connection Types UC motors

Connector B
for Molex Mill-Grid 51110-0660

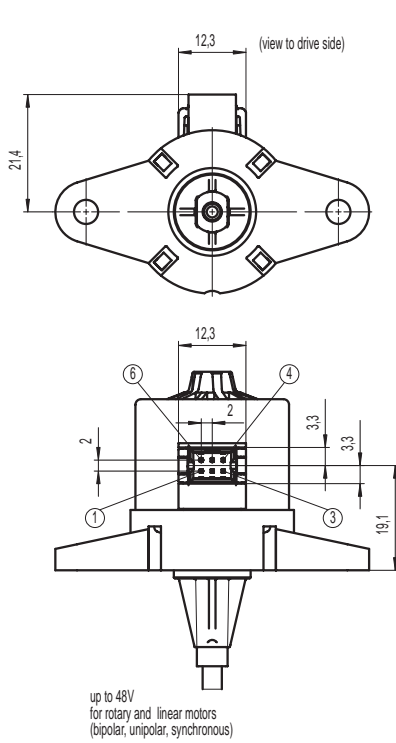

Connector C
for Tyco Modu IV 0-1740209-6

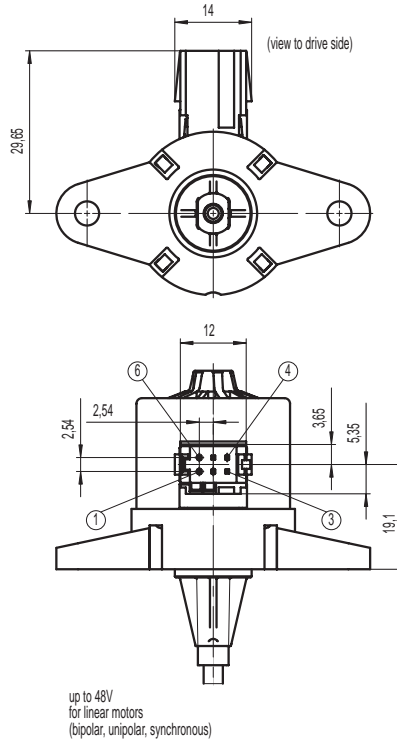

Connector D
for Molex C-Grid III 90142-0006

