

UCC1/7

Dimensions (mm)	∅ 28 x 31
Travel (mm)	10/13
Voltage (V) **	12–230
Speed (mm/s)	
50 Hz	4.16
60 Hz	5
Max. Force (N)*	48



* Depends on winding, frequency and lifetime required. Values for connector versions (C, D) / lead wire versions (N) up to 20 % lower.
Driving against mechanical end stops is not permissible due to the risk of jamming. JE will not be responsible for product warranty or any liabilities associated with the application of drive against end stop.
Radial forces on the shaft will reduce life time and performance.

** regard circuit diagram and connector type

Note: All force and power output values are minimum values, at rated voltage and motor temperature 23°C.

Standard Data

Climatic class	wide-spread according to DIN IEC 60721-2-1 : 2015
Ambient temperature operation	°C -15 ... +60
Ambient temperature storage	°C -20 ... +100
Thermal resistance at f=0 R _{therm}	29 K/W
Thermal class	130 (B) according to DIN EN 60085 : 2008
Winding coil temperature increase	K 60
Approval	standard
Mounting	any position
Electrical connection	connector type B, C, D, N
Protection	IP40 according to DIN EN 60529 : 2014
Weight	67 g
Rotor stalling	motor can be stopped when voltage is applied, without being overheated
Bearings	ball bearing

Order Reference

Type	Synchronous Motor	UCC	13	N	B4	D	1E
Configuration	13 standard magnet	73 stronger magnet					
Approval	N						
Voltage/frequency	see next pages						
Connection	B, C see next pages "Connection Types"						
D							
Shaft	1E Travel 13 mm ± 0.7 mm (other standard shafts see under dimensions)						



All specifications are representative only and maybe subject to variation. For confirmation of values, please contact Johnson Electric.
Please also read "Saia Motors Important Notes" on catalog or at www.johnsonelectric.com/SaiaMotorsNotes

Technical Data

Rated frequency	Hz	50		
Axial speed	mm/s	4.16		
Tolerance of voltage		standard power supply system +10% / -10%		
Linear travel max.	mm	10/13		
Axial play at ± 20 N force	mm	< 0.25		
Winding temperature T _{max}		130		
Rated voltage U _N	V	12	24	110 ¹⁾
Duty cycle	%	100	100	100
Resistance R ₂₀	Ω	53	210	5000
Capacitor C ₅₀	μF/V ±10%	18/20	4.7/40	0.22/200
Winding code		B1	B4	C8

Circuit diagram Parallel circuit 12 V, 24 V, 48 V

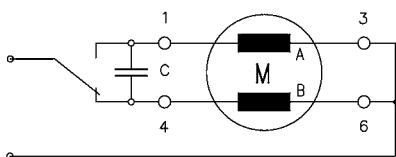

Parallel circuit 230 V (only for connector N) with 110 V motor and resistor R_V

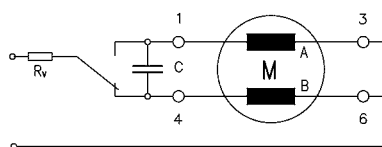

R_V = 5.6 kΩ, 3 W

Series circuit 110 V (only for connector N)

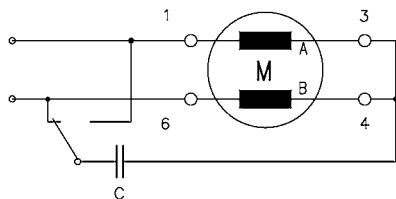

Parallel circuit 230 V (only for connector N) with 110 V motor and capacitor C_V

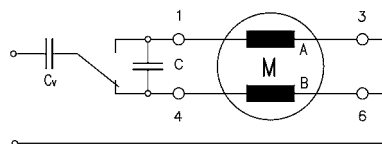

C_V = 0.33 μF, 250 VAC

switch to

- 1 Pull (in)
- 4 Push (out)
- 6 Push (out)
(for series circuit)

¹⁾ 110 V version available with 150 mm lead wires AWG26 only
Standard versions:

Shaft type (see dimensions)	Order code
1E	UCC13NC8N1EZ4
1S	UCC13NC8N1SZ4
1R	UCC13NC8N1RZ4
1Q	UCC13NC8N1QZ4

Dimensions Version with Connector D, with 13 mm travel, shaft 1E

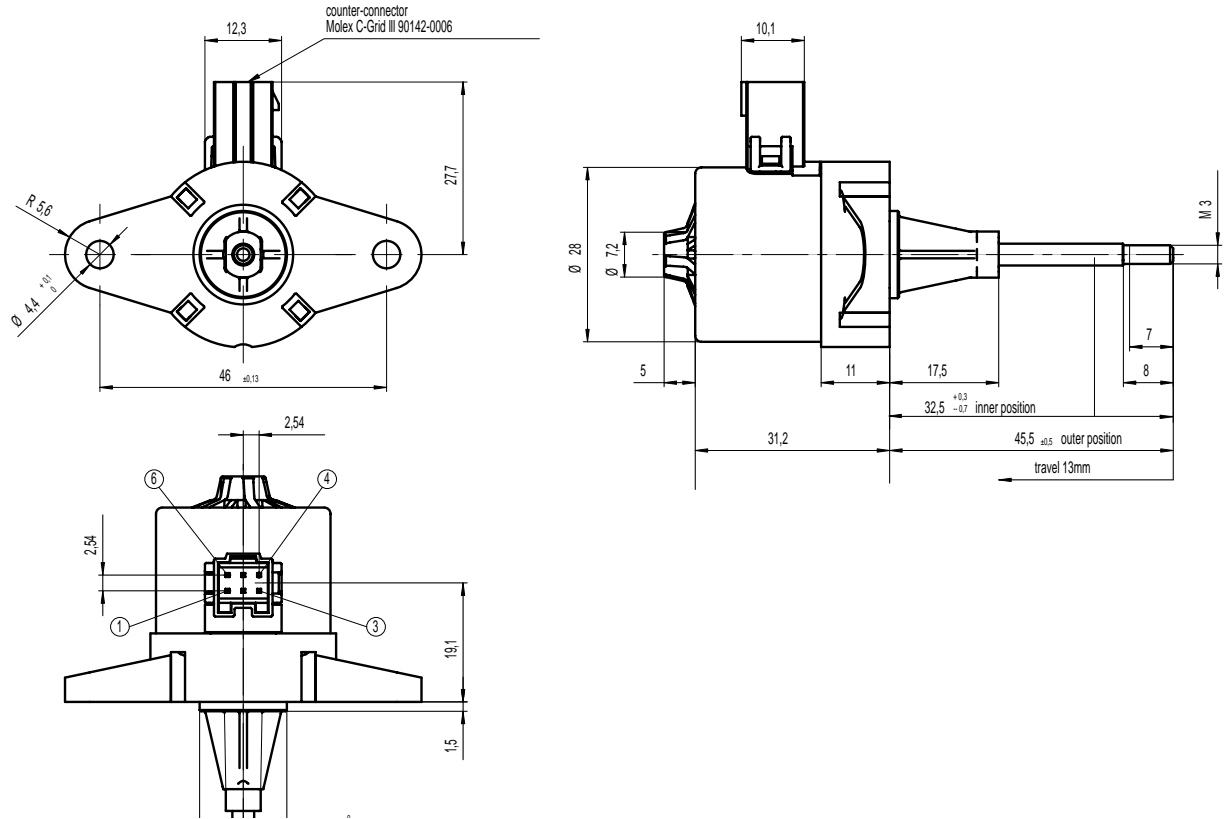

Version with Connector D, with 50..150 mm travel, shaft 1R, 1S, 1Q - only for pull operation

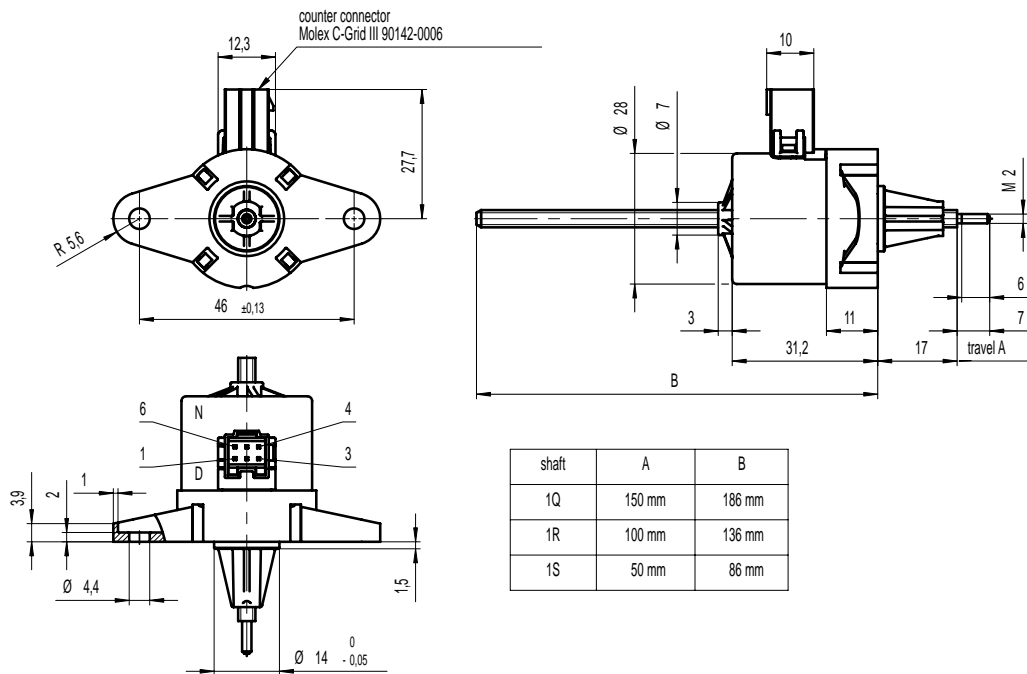

Please note:

The linear motor with non-captive shaft needs an external antirotation fixation and guidance. The antirotation is to produce the linear movement.

Application design of the guidance has to consider a maximum tolerance of 0.2° from the ideal axis.

The shaft guidance has strong influence on motor live time.

Dimensions 110 V version with lead wires

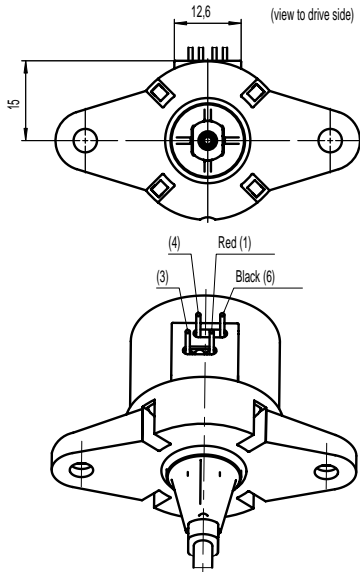

different lead colours for 110V (230V)
for rotary synchronous motors in serials circuit

Force with shaft 1E

		connector version		lead wire version	
		50 Hz	60 Hz	50 Hz	60 Hz
UCC1	100 %	33 N	35 N	26 N	29 N
	30 %	39 N	41 N	31 N	34 N
UCC7	100 %	39 N	41 N	32 N	35 N
	30 %	47 N	48 N	38 N	42 N

UCK

UCK 1/7

Dimensions (mm)	∅ 28 x 31
Travel (mm)	10/13
Voltage (V) **	12–230
Speed (mm/s)	
50 Hz	8.33
60 Hz	10
Max. Force (N)*	49



* Depends on winding, frequency and lifetime required. Values for connector versions (C, D) / lead wire versions (N) up to 20 % lower.
 Driving against mechanical end stops is not permissible due to the risk of jamming. JE will not be responsible for product warranty or any liabilities associated with the application of drive against end stop.
 Radial forces on the shaft will reduce life time and performance.

** regard circuit diagram and connector type

Note: All force and power output values are minimum values, at rated voltage and motor temperature 23°C.

Standard Data

Climatic class	wide-spread according to DIN IEC 60721-2-1 : 2015
Ambient temperature operation	°C -15 ... +60
Ambient temperature storage	°C -20 ... +100
Thermal resistance at f=0 R _{therm}	29 K/W
Thermal class	130 (B) according to DIN EN 60085 : 2008
Winding coil temperature increase	K 60
Approval	standard
Mounting	any position
Electrical connection	connector type B, C, D, N
Protection	IP40 according to DIN EN 60529 : 2014
Weight	67 g
Rotor stalling	motor can be stopped when voltage is applied, without being overheated
Bearings	ball bearing

Order Reference

Type	Synchronous Motor	UCK	13	N	B4	D	1E
Configuration	13 standard magnet	73 stronger magnet					
Approval	N						
Voltage/frequency	see next page						
Connection	B, C see next pages "Connection Types"						
	D						
Shaft	1E Travel 13 mm ± 0.7 mm (other standard shafts see under dimensions)						



All specifications are representative only and maybe subject to variation. For confirmation of values, please contact Johnson Electric.
 Please also read "Saia Motors Important Notes" on catalog or at www.johnsonelectric.com/SaiaMotorsNotes

Technical Data

Rated frequency	Hz	50		
Speed	mm/s	8.33		
Tolerance of voltage		standard power supply system +10% / -10%		
Axial play at 20 N force	mm	< 0.25		
Duty cycle		100 %		
Winding temperature T _{max}		130		
Rated voltage U _N	V	12	24	110 ¹⁾
Duty cycle	%	100	100	100
Resistance R ₂₀	Ω	59	230	5500
Capacitor C ₅₀	μF / V ±10%	22/20	5.6/40	0.27/200
Winding code		B1	B4	C8/H8

Circuit diagram Parallel circuit 12 V, 24 V, 48 V

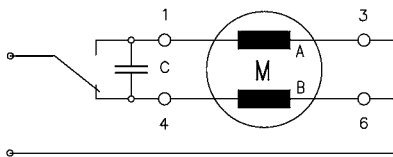

Parallel circuit 230 V (only for connector N) with 110 V motor and resistor R_V

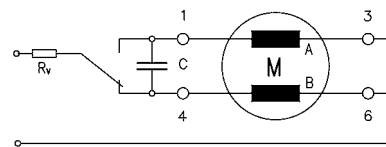

R_V = 5.6 kΩ, 3 W

switch to

- 1 Pull (in)
- 4 Push (out)
- 6 Push (out)
(for series circuit)

Series circuit 110 V (only for connector N)

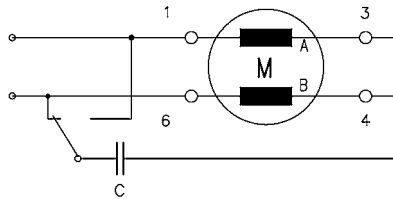

Parallel circuit 230 V (only for connector N) with 110 V motor and capacitor C_V

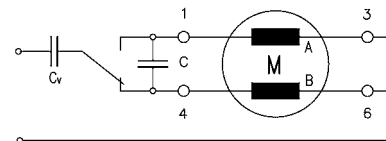

C_V = 0.33 μF, 250 VAC

¹⁾ 110 V version available with 150 mm lead wires AWG26 only
Standard versions:

Shaft type (see dimensions)	Order code
1E	UCK13NC8N1EZ2
1S	UCK13NC8N1SZ2
1R	UCK13NC8N1RZ2
1Q	UCK13NC8N1QZ2

Dimensions Version with Connector D, with 13 mm travel, shaft 1E

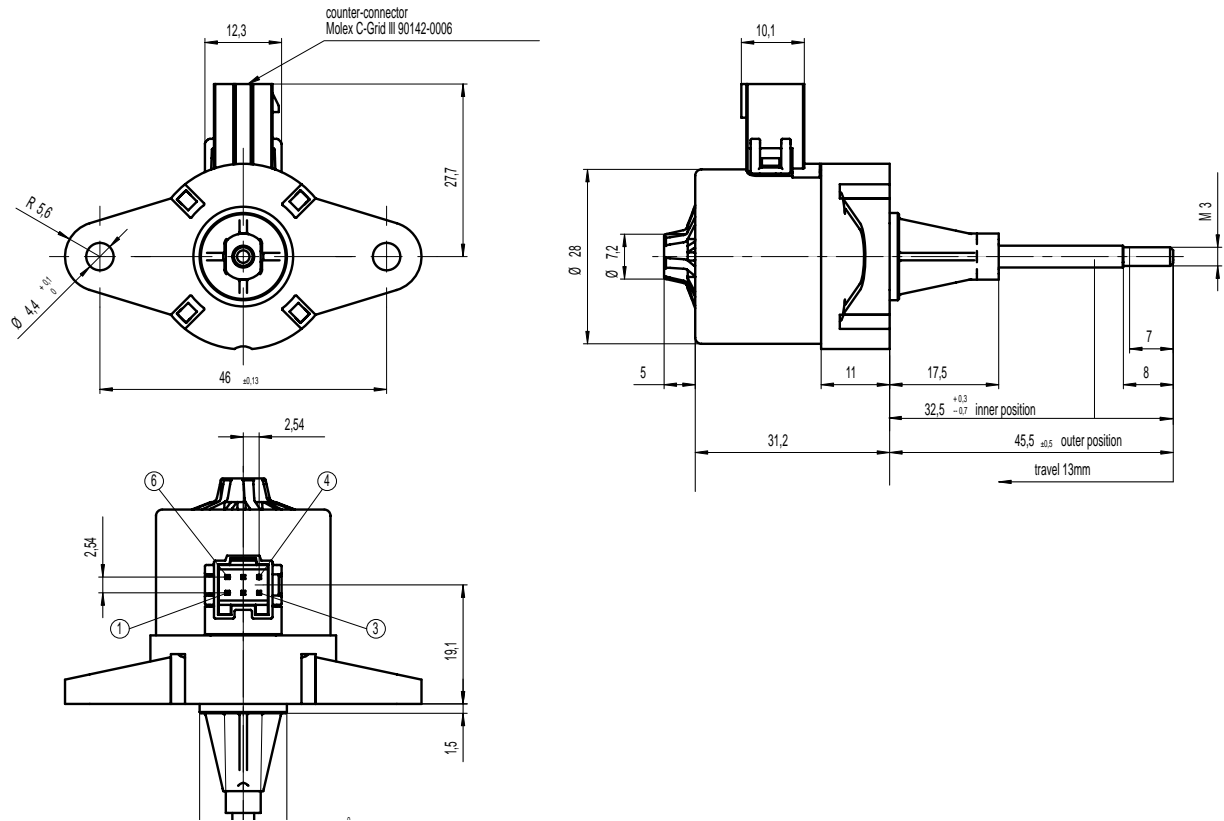

Version with Connector D, with 50..150 mm travel, shaft 1R, 1S, 1Q - only for pull operation

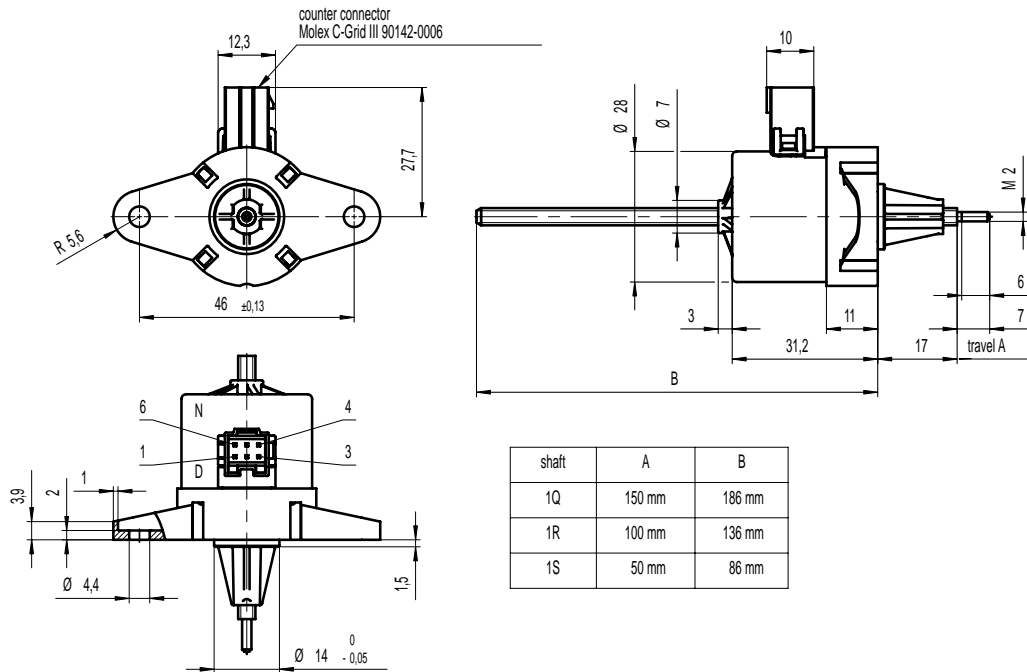

Please note:

The linear motor with non-captive shaft needs an external antirotation fixation and guidance. The antirotation is to produce the linear movement.

Application design of the guidance has to consider a maximum tolerance of 0.2° from the ideal axis.

The shaft guidance has strong influence on motor live time.

UCK

Dimensions 110 V version with lead wires

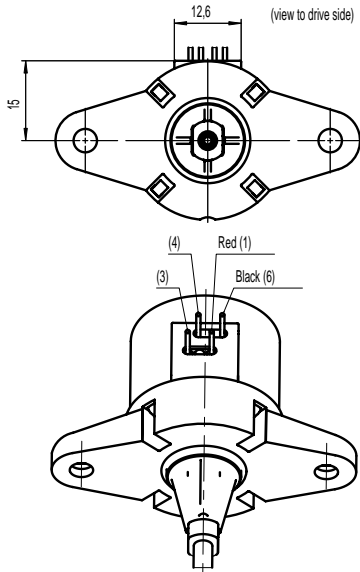

different lead colours for 110V (230V)
for rotary synchronous motors in serials circuit

Force with shaft 1E

		connector version		lead wire version	
		50 Hz	60 Hz	50 Hz	60 Hz
UCK1	100 %	27 N	28 N	19 N	19 N
	30 %	35 N	41 N	24 N	26 N
UCK7	100 %	34 N	33 N	22 N	21 N
	30 %	44 N	49 N	29 N	30 N

Connection Types UC motors

Connector B
for Molex Mini-Grid 51110-0660

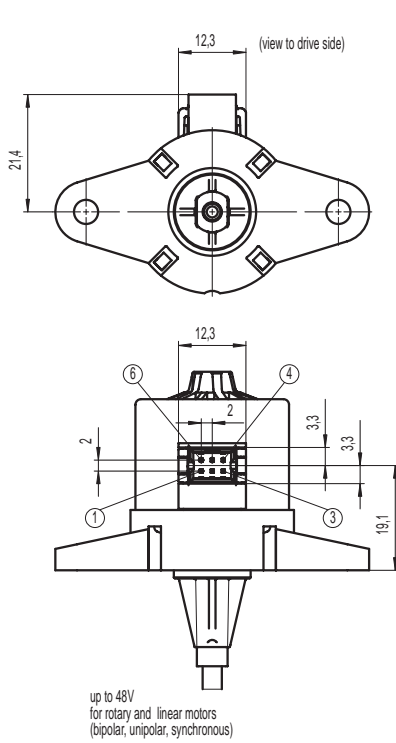

Connector C
for Tyco Modu IV 0-1740209-6

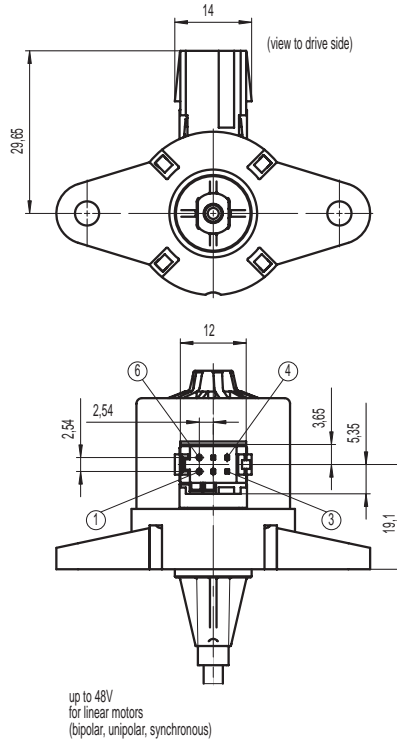

Connector D
for Molex C-Grid III 90142-0006

