

UAT3

UAT3

Dimensions (mm)	Ø 20 × 17.2
Voltage (V)	12-60
Speed (rpm) 50 Hz	600
60 Hz	720
Pole number	10
Running torque (cNm) 50 Hz	0.32 (standard magnet, stronger magnet on request)
60 Hz	0.3
Power output (W) 50 Hz	0.20 (standard magnet, stronger magnet on request)
60 Hz	0.23
Gear combination	on request



Note: Running torque = Pull-out torque (starting motor at no load, then torque increase)
 Running torque and Power output are minimum values, at rated voltage and motor temperature 23°C

Standard Data

Climatic class	„wide-spread“ according to DIN IEC 60721-2-1 : 2015
Ambient temperature operation	°C -20 ... +60
Ambient temperature storage	°C -40 ... +100
Thermal resistance at f=0 R _{therm}	47 K/W
Thermal class	130 (B) according to DIN EN 60085 : 2008
Approval	standard
Mounting	any position
Electrical connection	lead wires AWG28, insulation Ø 0.82 mm
Protection	IP40 according to DIN EN 60529 : 2014
Weight	22 g
Rotor stalling	motor can be stopped when voltage is applied, without being overheated
Bearings	sintered bronze, self-lubricating

Order Reference

Type	Synchronous Motor	UAT3	3	N	B4	R	E
Rotor shaft, mounting	0 centring 8 mm, mounting plate with screw M2						
	3 centring 8 mm, mounting plate with long holes						
	5 centring 8 mm, mounting plate (for clipping)						
	A centring 6 mm, mounting plate with screw M2						
	E centring 6 mm, mounting plate with long holes						
	G centring 6 mm, mounting plate (for clipping)						
Approval	N Approval Standard						
Voltage/Frequency	See next page						
Direction	reversible						
Cable	E cable 150 mm with Tyco connector CT 173977-4 (other on request)						



All specifications are representative only and maybe subject to variation. For confirmation of values, please contact Johnson Electric.
 Please also read "Saia Motors Important Notes" on catalog or at www.johnsonelectric.com/SaiaMotorsNotes

UAT3

Technical Data

Rated frequency	Hz	50	60
Speed n	rpm	600	720
Power consumption	W	1.4	1.4
Power output	W	0.20	0.23
Running torque	cNm	0.32	0.30 (standard magnet, stronger magnet on request)
Rotor inertia J _R	gcm ²	0.26	
Detent torque M _s	mNm	> 0.6	
Tolerance of voltage		standard power supply system + 10% / - 10%	
Duty cycle		100%	
Winding temperature T _{max}	°C	130	
Direction of rotation		reversible	
Rated voltage U _N	V	24	24
Duty cycle	%	100	100
Resistance R ₂₀	Ω	430	430
Capacitor C _n (50Hz)	μF	3.3	2.7
Winding code	50Hz/60Hz	B4	G4

Circuit diagram Parallel circuit

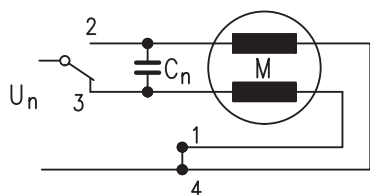

switch to
2 = clockwise rotation
3 = counter clockwise rotation

Dimensions

motor type	∅ D	
UAT30	∅ 8	0 -0.05
UAT3A	∅ 6	0 -0.05

motor type	∅ D	
UAT33	∅ 8	0 -0.05
UAT3E	∅ 6	0 -0.05

motor type	∅ D	
UAT35	∅ 8	0 -0.05
UAT3G	∅ 6	0 -0.05

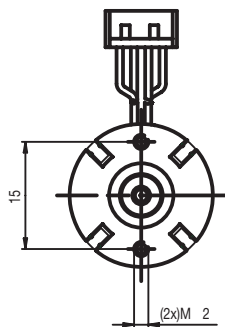

Use bolts with thread length 4mm max. Screw in torque 10cNm max.

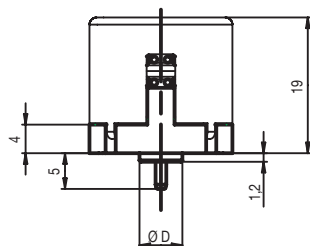
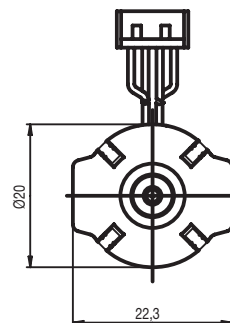
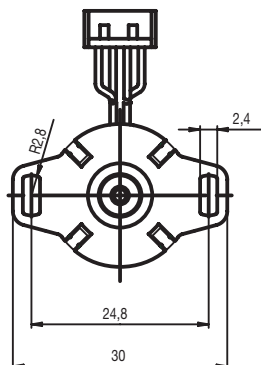

6-FRONT

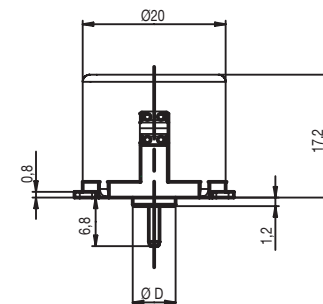
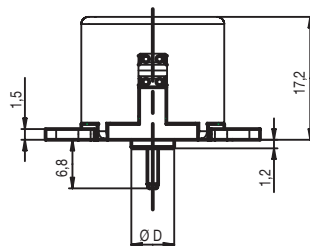

UAT3

Rotational

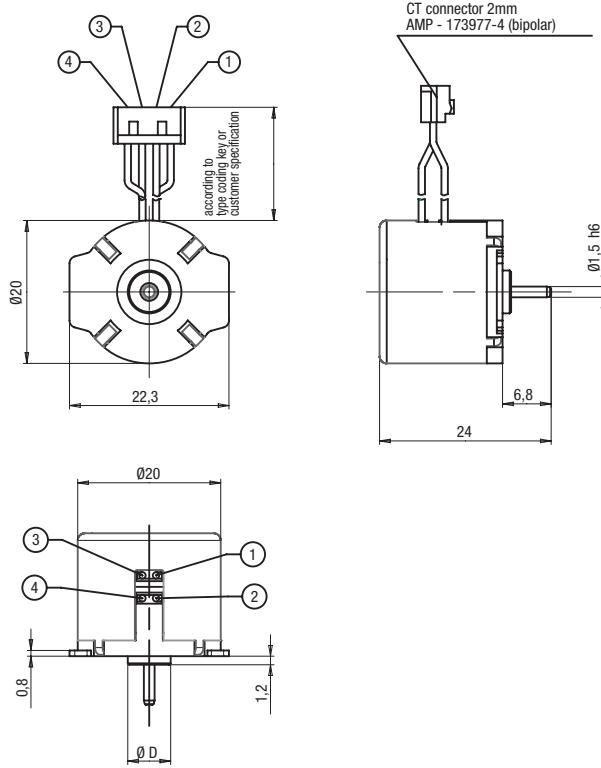

UCM1/7

Dimensions (mm)	∅ 28 x 24
Voltage (V) *	12–230
Speed (rpm) 50 Hz	250
Pole number	24
Running torque (cNm) 50 Hz	1.15–1.7
60 Hz	1.15–1.7
Power output (W) 50 Hz	0.3–0.44
60 Hz	0.36–0.53
Gear combination	D, M, B, F

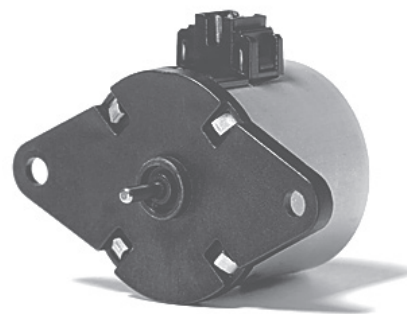

* regard circuit diagram and connector type

Note: Running torque = Pull-out torque (starting motor at no load, then torque increase)
 Running torque and Power output are minimum values, at rated voltage and motor temperature 23°C

Standard Data

Climatic class	„wide-spread“ according to DIN IEC 60721-2-1 : 2015
Ambient temperature operation	°C -15 ... +60
Ambient temperature storage	°C -20 ... +100
Thermal resistance at f=0 R _{therm}	29 K/W
Thermal class	130 (B) according to DIN EN 60085 : 2008
Approval	standard
Mounting	any position
Electrical connection	connector type D or N
Protection	IP30 according to DIN EN 60529 : 2014
Weight	54 g
Rotor stalling	motor can be stopped when voltage is applied, without being overheated
Bearings	Sintered bronze, self-lubricating

Order Reference

Type	Synchronous Motor	UCM	1	0	N	B4	R	D	
Configuration	1 standard magnet 7 stronger magnet								
Rotor shaft, mounting	3 centring 8 mm, shaft 2.0 mm, screw plate 4 centring 8 mm, shaft 1.5 mm, screw plate 0 centring 8 mm, shaft 2.0 mm, clip 1 centring 8 mm, shaft 1.5 mm, clip	E	centring 10 mm, shaft 2.0 mm, screw plate	K	centring 10 mm, shaft 1.5 mm, screw plate	A	centring 10 mm, shaft 2.0 mm, clip	C	centring 10 mm, shaft 1.5 mm, clip
Approval	N Approval Standard								
Voltage/Frequency	see next pages								
Direction	R reversible								
Connection	D see next pages “Connection Types” and page 145 “Connection Types” for B N								

All specifications are representative only and maybe subject to variation. For confirmation of values, please contact Johnson Electric.
 Please also read “Saia Motors Important Notes” on catalog or at www.johnsonelectric.com/SaiaMotorsNotes



Technical Data

		UCM1	UCM1	UCM7	UCM7
Rated frequency	Hz	50	60	50	60
Speed n	rpm	250	300	250	300
Detent torque M _s	cNm	0.18	0.18	0.36	0.36
Power consumption	VA	2.2	2.2	2.2	2.2
Rotor inertia J _R	gcm ²	2.2	2.2	2.4	2.4
Tolerance of voltage		standard power supply system +10%/-10%			
Duty cycle		100%			
Winding temperature T _{max}	°C	130			
Direction of rotation		reversible			

Specific Technical Data Lead Wire Versions (Connection N)

Performance	Running torque	cNm	1.15	1.15	1.45	1.45
	Power output	W	0.3	0.36	0.38	0.45
Capacitors	Rated voltage U _N	V	24	110		
	Duty cycle	%	100	100		
	Resistance R ₂₀	Ω	210	5000		
	Capacitor C _n (50Hz)	μF/V ±10%	4.7/40	0.22/200		
	Winding code	50Hz/60Hz	B4/G4	C8/H8		

Specific Technical Data Connector Versions (Connector D and B)

Performance	Running torque	cNm	1.4	1.4	1.7	1.7
	Power output	W	0.36	0.44	0.44	0.53
Capacitors	Rated voltage U _N	V	12	24		
	Duty cycle	%	100	100		
	Resistance R ₂₀	Ω	53	210		
	Capacitor C ₅₀	μF/V ±10%	18/20	4.7/40		
	Winding code		B1	B4		

Circuit diagram Parallel circuit 12 V, 24 V, 48 V

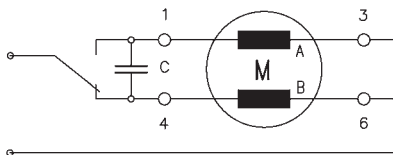

Parallel circuit 230 V (only for lead wire versions) with 110 V motor and resistor R_v

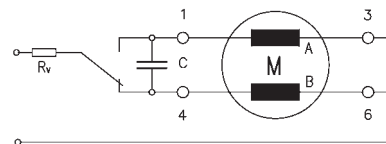

Parallel circuit 230 V (only for lead wire versions) with 110 V motor and capacitor C_v

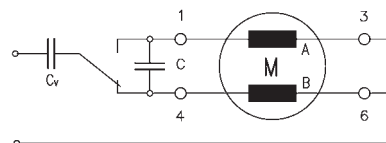

switch to

- 1 clockwise rotation
- 4 counter clockwise rotation
- 6 counter clockwise rotation (for series circuit)

Series resistor R_v = 5.6 kΩ, 3 W

Series capacitor C_v = 0.33 μF, 250 VAC

Dimensions Version with Connector D

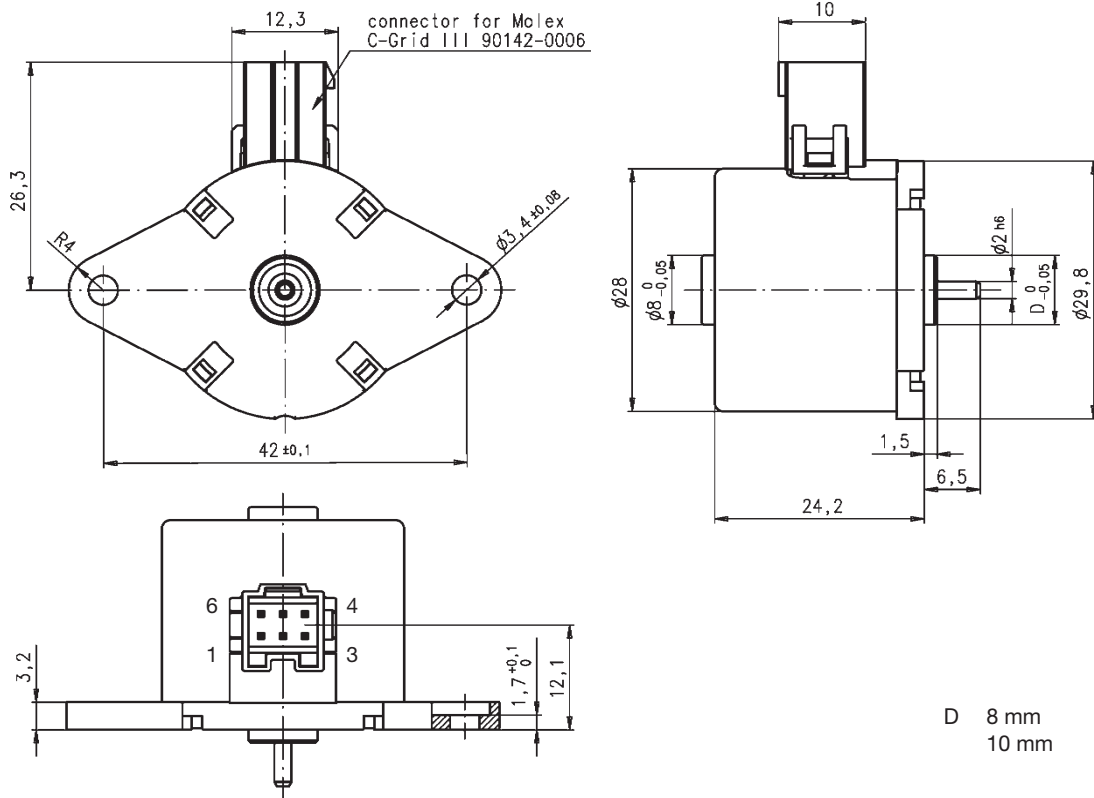

Version with Connection N

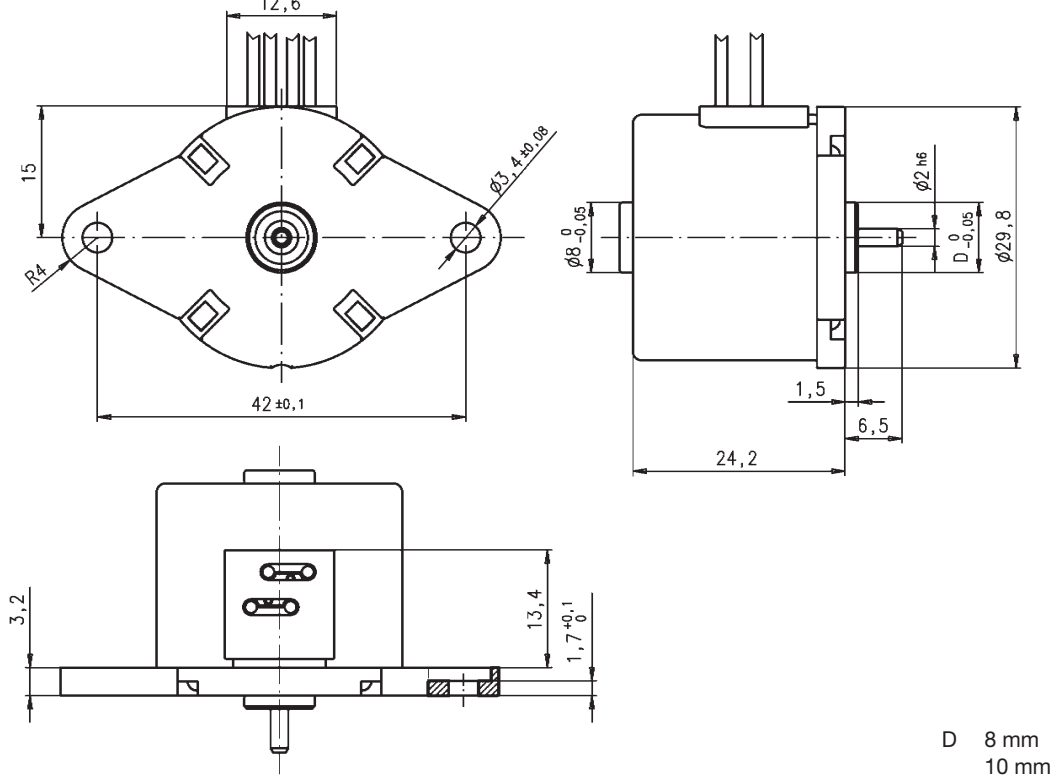

UCR

UCR1/7

 Dimensions (mm) \varnothing 28 x 24

Voltage (V) * 12–230

Speed (rpm) 50 Hz 500

Pole number 12

Running torque

(cNm) 50 Hz 0.76–1.2

60 Hz 0.72–1.05

Power output (W)

50 Hz 0.40–0.63

60 Hz 0.45–0.66

Gear combination D, M, B, F

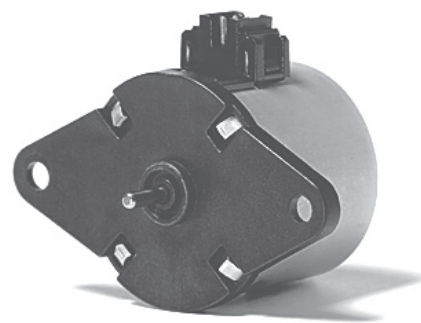

* regard circuit diagram and connector type

Note: Running torque = Pull-out torque (starting motor at no load, then torque increase)

Running torque and Power output are minimum values, at rated voltage and motor temperature 23°C

Standard Data

Climatic class	wide-spread according to DIN IEC 60721-2-1 : 2015
Ambient temperature operation	°C -15 ... +60
Ambient temperature storage	°C -20 ... +100
Thermal resistance at f=0 R _{therm}	29 K/W
Thermal class	130 (B) according to DIN EN 60085 : 2008
Approval	standard
Mounting	any position
Electrical connection	connector type D or N
Protection	IP30 according to DIN EN 60529 : 2014
Weight	54 g
Rotor stalling	motor can be stopped when voltage is applied, without being overheated
Bearings	Sintered bronze, self-lubricating

Order Reference

Type	Synchronous Motor	UCR	1	0	N	B4	R	D
Configuration	1 standard magnet 7 stronger magnet							
Rotor shaft, mounting	3 centring 8 mm, shaft 2.0 mm, screw plate E 4 centring 8 mm, shaft 1.5 mm, screw plate K 0 centring 8 mm, shaft 2.0 mm, clip A 1 centring 8 mm, shaft 1.5 mm, clip C							
Approval	N Approval Standard							
Voltage/Frequency	see next pages							
Direction	R reversible							
Connection	D see next pages "Connection Types" and page 145 "Connection Types" for B N Cable							



All specifications are representative only and maybe subject to variation. For confirmation of values, please contact Johnson Electric.
 Please also read "Saia Motors Important Notes" on catalog or at www.johnsonelectric.com/SaiaMotorsNotes

Technical Data

		UCR1	UCR1	UCR7	UCR7
Rated frequency	Hz	50	60	50	60
Speed n	rpm	500	600	500	600
Detent torque M _s	cNm	0.2	0.2	0.45	0.45
Power consumption	VA	2.4	2.5	2.3	2.4
Rotor inertia J _R	gcm ²	2.1	2.1	2.4	2.4
Tolerance of voltage		standard power supply system +10%/-10%			
Duty cycle		100%			
Winding temperature T _{max}	°C	130			
Direction of rotation		reversible			

Specific Technical Data Lead Wire Versions (Connection N)

Performance	Running torque	cNm	0.76	0.72	0.93	0.85
	Power output	W	0.40	0.45	0.49	0.53
Capacitors	Rated voltage U _N	V	12	24	110	
	Duty cycle	%	100	100	100	
	Resistance R ₂₀	Ω	60	230	5500	
	Capacitor C _n (50Hz)	μF/V ±10%	22/20	5.6/40	0.27/200	
	Winding code	50Hz/60Hz	B1/G1	B4/G4	C8/H8	

Specific Technical Data Connector Versions (Connector D and B)

Performance	Running torque	cNm	0.94	0.87	1.2	1.05
	Power output	W	0.50	0.54	0.63	0.66
Capacitors	Rated voltage U _N	V	12	24		
	Duty cycle	%	100	100		
	Resistance R ₂₀	Ω	59	230		
	Capacitor C _n (50Hz)	μF/V ±10%	22/20	5.6/40		
	Winding code	50Hz/60Hz	B1	B4		

Circuit diagram Parallel circuit 12 V, 24 V, 48 V, 110 V

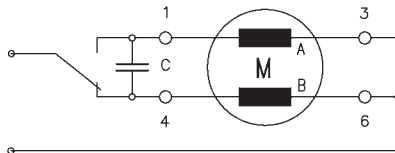

Parallel circuit 230 V (only for lead wire versions) with 110 V motor and resistor R_v

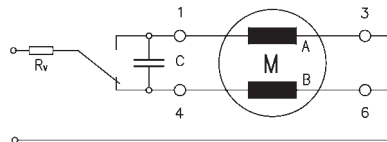

switch to

- 1 clockwise rotation
- 4 counter clockwise rotation
- 6 counter clockwise rotation (for series circuit)

Parallel circuit 230 V (only for lead wire versions) with 110 V motor and capacitor C_v

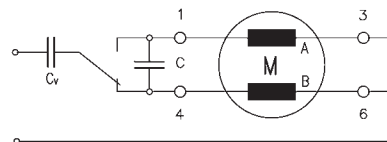

Series resistor R_v = 5.6 kΩ, 3 W

Series capacitor C_v = 0.33 μF, 250 VAC

UCR

Rotational

Dimensions Version with Connector D

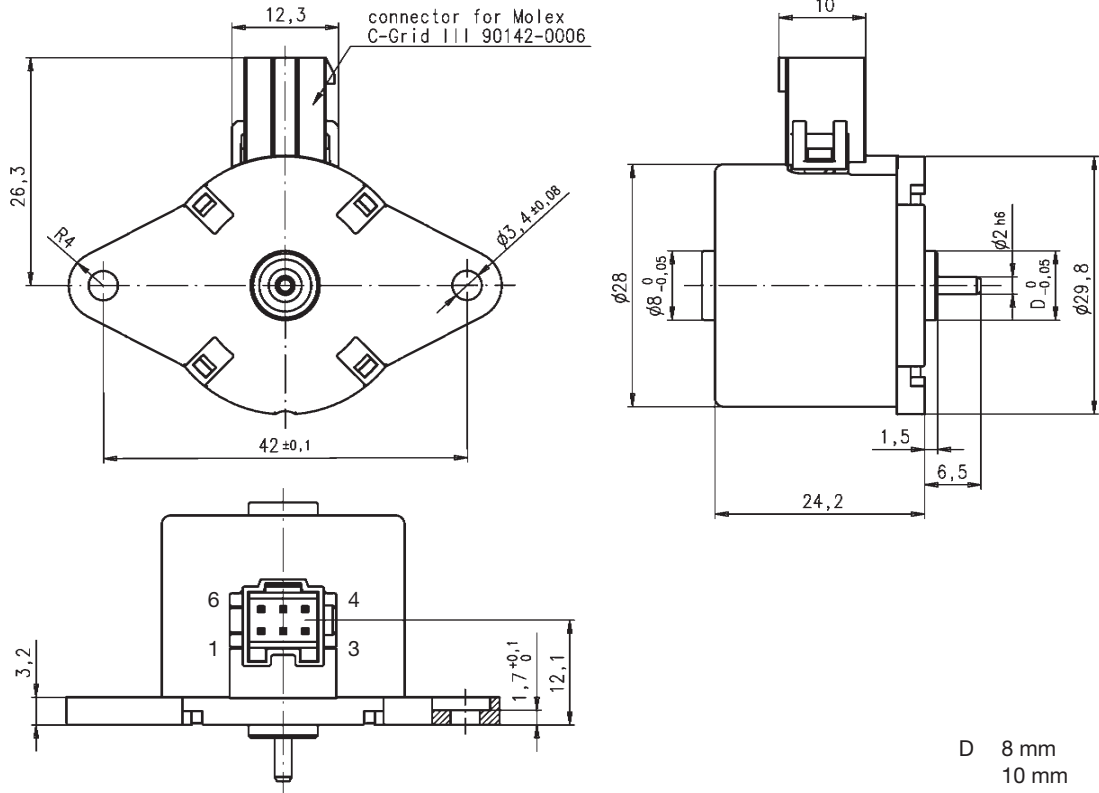

Version with Connection N

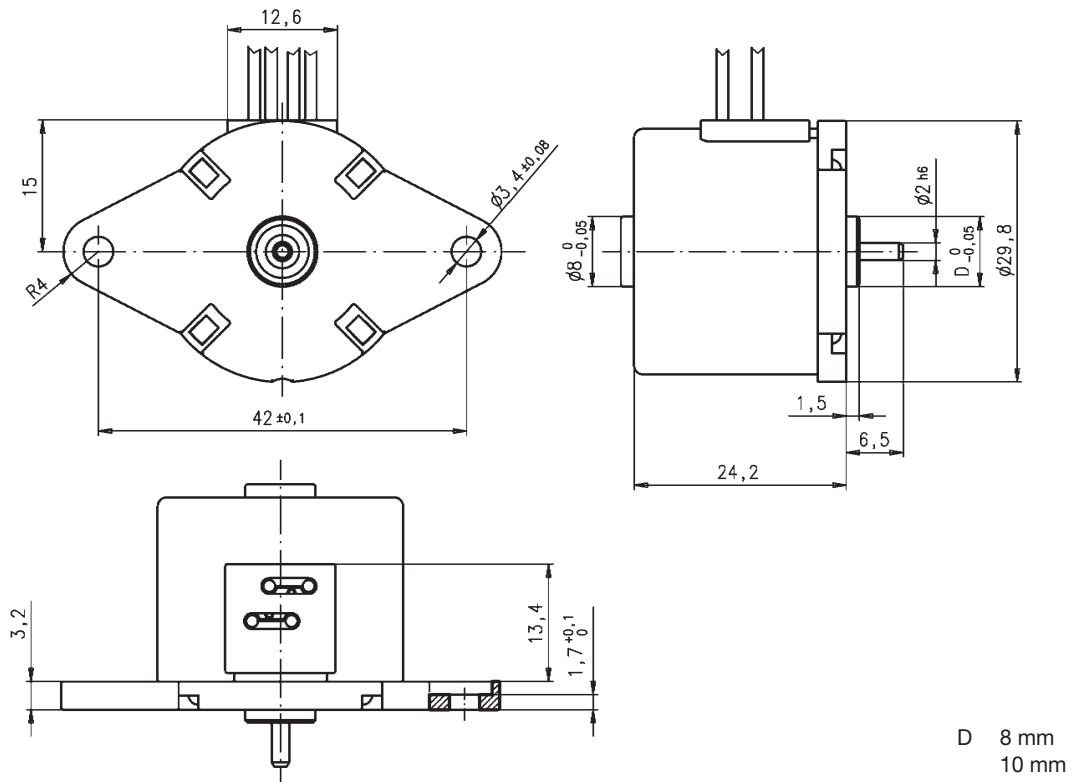

UBR1

UBR1

Dimensions (mm) Ø 36 x 21

Voltage (V) 12–230

 Speed (rpm) 50 Hz 250
 60 Hz 300

Pole number 24

 Running torque
 (cNm) 50 Hz 0.77
 60 Hz 0.77

 Power output (W)
 50 Hz 0.20
 60 Hz 0.24

Gear combination D, M, B, F, V, J

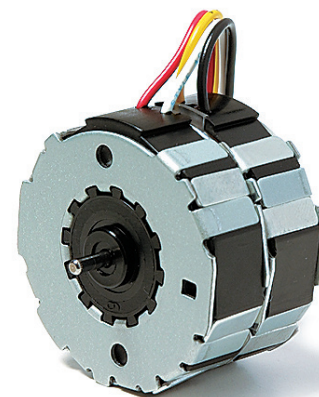

Rotational

Note: Running torque = Pull-out torque (starting motor at no load, then torque increase)
 Running torque and Power output are minimum values, at rated voltage and motor temperature 23°C

Standard Data

Climatic class	wide-spread according to DIN IEC 60721-2-1 : 2015
Ambient temperature operation	°C -15...+55
Ambient temperature storage	°C -20...+100
Thermal resistance at f=0 R _{therm}	27 K/W
Thermal class	105 (A) according to DIN EN 60085 : 2008
Approval	standard (UL/CSA on request)
Mounting	any position
Electrical connection	cable
Protection	IP40 according to DIN EN 60529 : 2014
Weight	60 g
Rotor stalling	motor can be stopped when voltage is applied, without being overheated
Bearings	sintered bronze, self-lubricating
Electric strength	according to DIN EN 60034-1/DIN EN 60335-1

Order Reference

Type	Synchronous Motor	UBR1	0	N	B4	R	E
Rotor shaft, mounting	0 centring 8 mm, shaft 2.0 mm, clip 1 centring 8 mm, shaft 1.5 mm, clip 3 centring 8 mm, shaft 2.0 mm, screw plate 4 centring 8 mm, shaft 1.5 mm, screw plate	A centring 10 mm, shaft 2.0 mm, clip C centring 10 mm, shaft 1.5 mm, clip E centring 10 mm, shaft 2.0 mm, screw plate K centring 10 mm, shaft 1.5 mm, screw plate					
Approval	N Approval Standard						
Voltage/Frequency	See next page						
Direction	reversible						
Cable	E cable 150 mm (other on request)						

All specifications are representative only and maybe subject to variation. For confirmation of values, please contact Johnson Electric.
 Please also read "Saia Motors Important Notes" on catalog or at www.johnsonelectric.com/SaiaMotorsNotes



UBR1

Technical Data

Rated frequency	Hz	50	60			
Speed n	rpm	250	300			
Power consumption	W	1.3	1.3			
Power output	W	0.20	0.24			
Running torque	cNm	0.77	0.77			
Rotor inertia J_R	gcm ²	2.8				
Detent torque M_s	cNm	0.19	0.19			
Tolerance of voltage		standard power supply system + 10% / - 10%				
Winding temperature T_{max}	°C	105				
Direction of rotation		reversible				
Rated voltage U_N	V	12	24	48	110	230
Duty cycle	%	100	100	100	100	100
Resistance R_{20}	Ω	104	385	1580	9160	11800
Capacitor C_n (50Hz, 60Hz)	$\mu F/V \pm 10\%$	12/20	3.3/34	0.82/70	0.15/170	0.22;0.12/170
Winding code	50Hz/60Hz	B1/G1	B4/G4	C1/H1	D1/J1	D5/J5

Circuit diagram Parallel circuit 12V, 24V, 48V, 110V

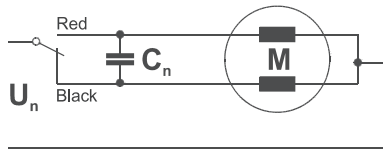

Parallel circuit 230V

$R_v = 12k \Omega$ / 1.5W for motors with resistance $R_{20} = 9160 \Omega$, code D1/J1

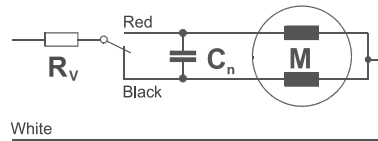

Series circuit 230V (for motors with resistance $R_{20} = 11800 \Omega$)

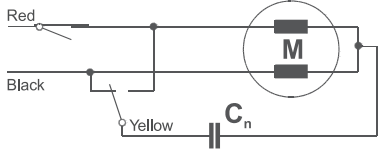

Parallel circuit 230V

$C_v = 0.18 \mu F$ (50Hz) / $0.15 \mu F$ (60Hz) / 200Vac with resistance $R_{20} = 9160 \Omega$

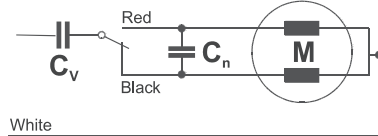

Red = clockwise rotation
Black = counter clockwise rotation

Dimensions Mounting with screw plate

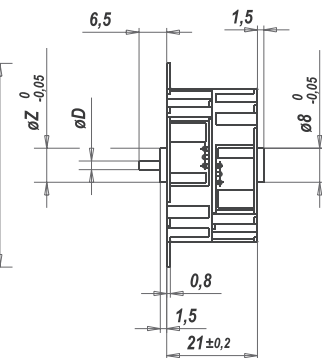
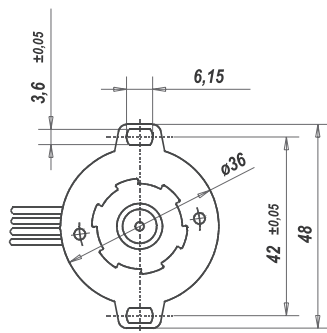

Mounting with snap-on clip
(item no. 4199 48230)

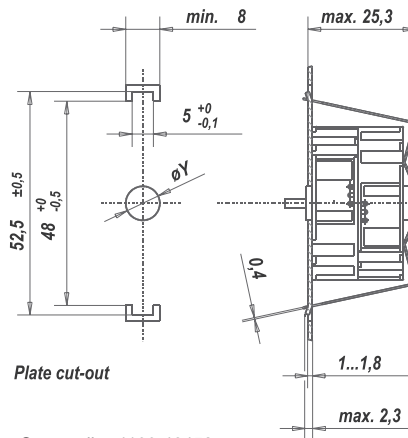

Screw clip: 4199 48450

$\varnothing D$ Rotor shaft
 $\varnothing 2$ h6
 $\varnothing 1.5$ js8

$\varnothing Z$	$\varnothing Y$
8	8F8
10	10F8

UBR2

UBR2

Dimensions (mm) Ø 36 x 21

Voltage (V) 12-230

 Speed (rpm) 50 Hz 500
 60 Hz 600

Pole number 12

 Running torque
 (cNm) 50 Hz 0.64
 60 Hz 0.61

 Power output (W)
 50 Hz 0.33
 60 Hz 0.38

Gear combination D, M, B, F, V, J

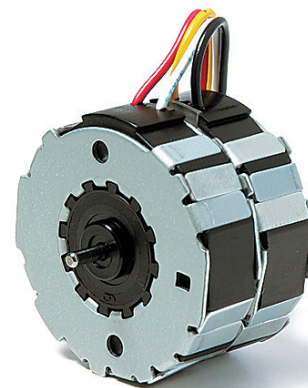

Rotational

Note: Running torque = Pull-out torque (starting motor at no load, then torque increase)
 Running torque and Power output are minimum values, at rated voltage and motor temperature 23°C

Standard Data

Climatic class	wide-spread according to DIN IEC 60721-2-1 : 2015
Ambient temperature operation	°C -15...+55
Ambient temperature storage	°C -20...+100
Thermal resistance at f=0 R _{therm}	27 K/W
Thermal class	105 (A) according to DIN EN 60085 : 2008
Approval	standard (UL/CSA on request)
Mounting	any position
Electrical connection	cable
Protection	IP40 according to DIN EN 60529 : 2014
Weight	60 g
Rotor stalling	motor can be stopped when voltage is applied, without being overheated
Bearings	sintered bronze, self-lubricating
Electric strength	according to DIN EN 60034-1/DIN EN 60335-1

Order Reference

Type	Synchronous Motor	UBR2	0	N	B4	R	E
Rotor shaft, mounting	0 centring 8 mm, shaft 2.0 mm, clip 1 centring 8 mm, shaft 1.5 mm, clip 3 centring 8 mm, shaft 2.0 mm, screw plate 4 centring 8 mm, shaft 1.5 mm, screw plate	A centring 10 mm, shaft 2.0 mm, clip C centring 10 mm, shaft 1.5 mm, clip E centring 10 mm, shaft 2.0 mm, screw plate K centring 10 mm, shaft 1.5 mm, screw plate					
Approval	N Approval Standard						
Voltage/Frequency	See next page						
Direction	reversible						
Cable	E cable 150 mm (other on request)						

All specifications are representative only and maybe subject to variation. For confirmation of values, please contact Johnson Electric.
 Please also read "Saia Motors Important Notes" on catalog or at www.johnsonelectric.com/SaiaMotorsNotes



UBR2

Technical Data

Rated frequency	Hz	50	60			
Speed n	rpm	500	600			
Power consumption	W	1.6	1.6			
Power output	W	0.33	0.38			
Running torque	cNm	0.64	0.61			
Rotor inertia J _R	gcm ²	2.8				
Detent torque M _s	cNm	0.21				
Tolerance of voltage		standard power supply system + 10% / - 10%				
Winding temperature T _{max}	°C	105				
Direction of rotation		reversible				
UBR2 Rated voltage U _N	V	12	24	48	110	230
Duty cycle	%	100	100	100	100	100
Resistance R ₂₀	Ω	87	344	1370	7650	12600
Capacitor C _n (50Hz, 60Hz)	μF/V ±10%	15/20	3.9/40	1/70	0.18/170	0.27;0.22/170
Winding code	50Hz/60Hz	B1/G1	B4/G4	C1/H1	D1/J1	D5/J5
UBR3 Rated voltage U _N	V	12	24	48		
Duty cycle	%	100	100	100		
Resistance R ₂₀	Ω	87	344	1370		
Capacitor C _n (50Hz)	μF/V ±10%	15/20	3.9/40	1/70		
Winding code	50Hz/60Hz	B1/G1	B4/G4	C1/H1		

Circuit diagram Parallel circuit 12V, 24V, 48V, 110V

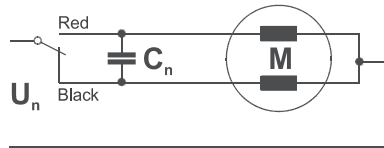

Parallel circuit 230V

R_v=8.2k Ω/1.5W for motors with resistance R₂₀= 7650 Ω, code D1/J1

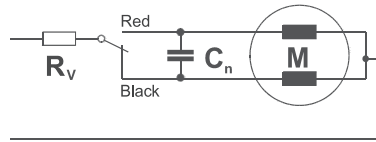

Series circuit 230V (for motors with resistance R₂₀= 12600 Ω)

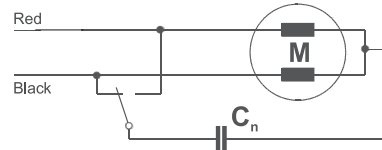

Parallel circuit 230V

C_v=0.22 μF (50Hz)/ 0.18 μF (60Hz)/200 Vac with resistance R₂₀=7650 Ω

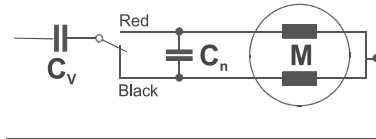

Red = clockwise rotation
Black = counter clockwise rotation

Dimensions Mounting with screw plate

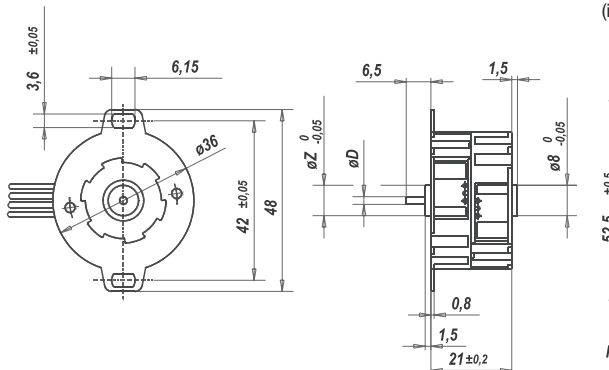

Mounting with snap-on clip
(item no. 4199 48230)

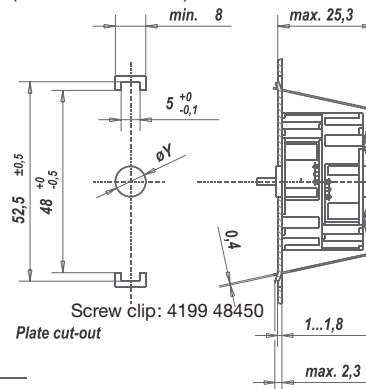

øD Rotor shaft

ø 2 h6

ø 1.5 js8

øZ øY

8 8F8

10 10F8

UDS

UDS1

Dimensions (mm)	∅ 48 x 18.5
Voltage (V)	6-230
Speed (rpm) 50 Hz	500
60 Hz	600
Pole number	12
Running torque (cNm) 50 Hz	0.77
60 Hz	0.68
Power output (W) 50 Hz	0.40
60 Hz	0.43
Gear combination	D, M, B, F, V, J



Rotational

Note: Running torque = Pull-out torque (starting motor at no load, then torque increase)
 Running torque and Power output are minimum values, at rated voltage and motor temperature 23°C

Standard Data

Climatic class	wide-spread according to DIN IEC 60721-2-1 : 2015
Ambient temperature operation	°C -15...+60
Ambient temperature storage	°C -20...+100
Thermal resistance at f=0 R _{therm}	17 K/W
Thermal class	105 (A) according to DIN EN 60085 : 2008 for approval standard 130 (B) according to DIN EN 60085 : 2008 for approval UL/CSA
Approval	standard/UL/CSA
Mounting	any position
Electrical connection	cable
Protection	IP40 according to DIN EN 60529 : 2014
Weight	102 g
Rotor stalling	motor can be stopped when voltage is applied, without being overheated
Bearings	plastic, self-lubricating
Electric strength	according to DIN EN 60034-1/DIN EN 60335-1

Order Reference

Type	Synchronous Motor	UDS1	0	N	B4	R	N
Rotor shaft, mounting	0 centring 8 mm, shaft 1.5 mm, clip 1 centring 8 mm, shaft 2.0 mm, clip						
Approval	N Approval Standard U Approval UL/CSA						
Voltage/Frequency	See next page						
Direction	R clockwise rotation L Counter-clockwise rotation						
Cable	N cable 150 mm (other on request)						

All specifications are representative only and maybe subject to variation. For confirmation of values, please contact Johnson Electric.
 Please also read "Saia Motors Important Notes" on catalog or at www.johnsonelectric.com/SaiaMotorsNotes



UDS

Technical Data

Rated frequency	Hz	50	60
Speed n	rpm	500	600
Power consumption*	W	2.4	1.8
Power output	W	0.40	0.43
Running torque	cNm	0.77	0.68
Rotor inertia J _R	gcm ²	11	
Detent torque M _s	cNm	0.23 (in direction of rotation)	
Tolerance of voltage		standard power supply system + 10% / - 10%	
Winding temperature T _{max}	°C	105 for approval Standard (N) 130 for approval UL/CSA	

Direction of rotation clockwise or counter-clockwise

UDS1	Rated voltage U _N	V	6	12	24	36	42	48	60	110	110-120	230	110/230	24/48
	Duty cycle	%	100	100	100	100	100	100	100	100	100	100	100	100
	Resistance R ₂₀	Ω	5.5	24	78	193	285	330	500	1830	1830	7500	2180/5500	105/260
	Winding code		A6/F6	B1/G1	B4/G4	B6/G6	B8/G8	C1/H1	C2/H2	C8/H8	D1/J1	D5/J5	R1/S1	R4/S4
UDS1 Approval U	Rated voltage U _N	V	6	12	24	48	100	110	110-120	230	110/230	24/48		
	Duty cycle	%	100	100	100	100	100	100	100	100	100	100		
	Resistance R ₂₀	Ω	5.5	24	78	330	1350	1830	1830	7500	2180/5500	105/260		
	Winding code		A6/F6	B1/G1	B4/G4	C1/H1	C7/H7	C8/H8	D1/J1	D5/J5	R1/S1	R4/S4		
UDS3	Rated voltage U _N	V	6	12	24	36	42	48	60	110	230	110/230	24/48	
	Duty cycle	%	100	100	100	100	100	100	100	100	100	100	100	
	Resistance R ₂₀	Ω	5.5	24	78	193	285	330	500	1830	7500	2180/5500	105/260	
	Winding code		A6/F6	B1/G1	B4/G4	B6/G6	B8/G8	C1/H1	C2/H2	C8/H8	D5/J5	R1/S1	R4/S4	
UDS4	Rated voltage U _N	V	12	24	42	48	110-120	230						
	Duty cycle	%	100	100	100	100	100	100						
	Resistance R ₂₀	Ω	23	98	322	390	2200	8700						
	Winding code		B1/G1	B4/G4	B8/G8	C1/H1	D1/J1	D5/J5						

*can vary for different windings (rated voltages)

Dimensions

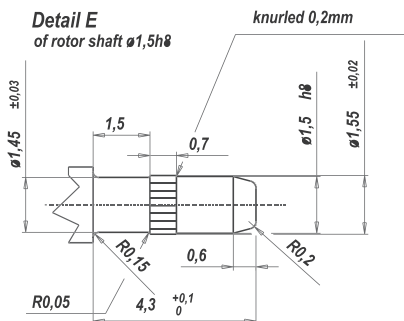
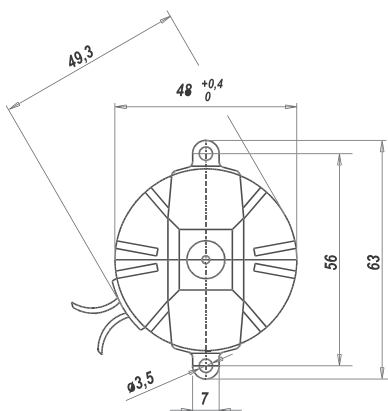

Mounting with screw clip
(item no. 4186 48200)

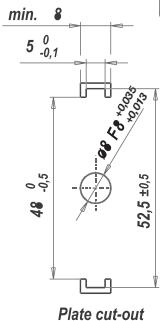
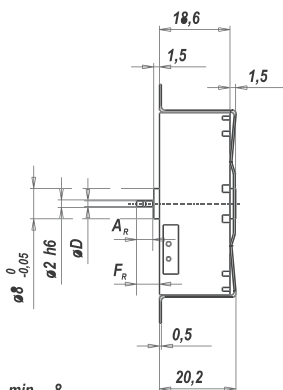

Mounting with snap-on clip
(item no. 4199 48000)

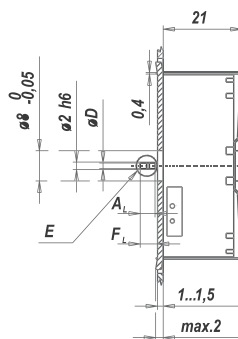

øD Rotor shaft	Clockwise		counter clockwise	
	Dim. A _R	Dim. F _R	Dim. A _L	Dim. F _L
1,5h8 ⁰ _{-0,014}	4,3 ^{+0,1}	6,05	4,3 ^{+0,1}	6,45
2h6 ⁰ _{-0,006}	—	6,05	—	6,45

UDR

UDR1

Dimensions (mm) Ø 48 x 24

Voltage (V) 12-230

Speed (rpm) 50 Hz 500
60 Hz 600

Pole number 12

Running torque (cNm) 50 Hz 1.3
60 Hz 1.2

Power output (W) 50 Hz 0.68
60 Hz 0.75

Gear combination D, M, B, F, V, J

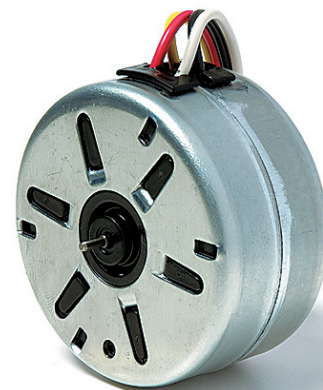

Rotational

Note: Running torque = Pull-out torque (starting motor at no load, then torque increase)
Running torque and Power output are minimum values, at rated voltage and motor temperature 23°C

Standard Data

Climatic class	wide-spread according to DIN IEC 60721-2-1 : 2015
Ambient temperature operation	°C -15...+60
Ambient temperature storage	°C -20...+100
Thermal resistance at f=0 R _{therm}	18 K/W
Thermal class	105 (A) according to DIN EN 60085 : 2008
Approval	standard/UL/CSA
Mounting	any position
Electrical connection	cable
Protection	IP30 according to DIN EN 60529 : 2014
Weight	132 g
Rotor stalling	motor can be stopped when voltage is applied, without being overheated
Bearings	sintered bronze, self-lubricating
Electric strength	according to DIN EN 60034-1/DIN EN 60335-1

Order Reference

Type	Synchronous Motor	UDR1	00	N	B4	R	N
Rotor shaft, mounting	0 centring 8 mm, shaft 1.5 mm, clip 1 centring 8 mm, shaft 2.0 mm, clip						
Approval	N Approval Standard U Approval UL/CSA						
Voltage/Frequency	See next page						
Direction	reversible						
Cable	N cable 150 mm (other on request)						

All specifications are representative only and maybe subject to variation. For confirmation of values, please contact Johnson Electric.
Please also read "Saia Motors Important Notes" on catalog or at www.johnsonelectric.com/SaiaMotorsNotes



UDR

Technical Data

Rated frequency	Hz	50	60			
Speed n	rpm	500	600			
Power consumption	W	2.1	2.2			
Power output	W	0.68	0.75			
Running torque	cNm	1.3	1.2			
Rotor inertia J _R	gcm ²	6.3				
Detent torque M _s	cNm	0.30				
Tolerance of voltage		standard power supply system + 10% / - 10%				
Winding temperature T _{max}	°C	105				
Direction of rotation		reversible				
Rated voltage U _N	V	12	24	48	110-120	230
Duty cycle	%	100	100	100	100	100
Resistance R ₂₀	Ω	50	200	800	5000	19000
Capacitor C _n (50Hz, 60Hz)	μF/V ±10%	27;22/20	6.8;4.7/34	1.5/70	0.27/170	0.068/340
Winding code	50Hz/60Hz	B1/G1	B4/G4	C1/H1	D1/J1	D5/J5

Circuit diagram Parallel circuit

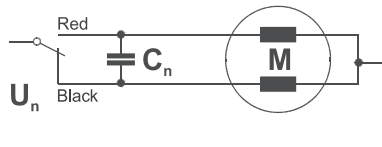

Red = clockwise rotation
Black = counter clockwise rotation

Dimensions

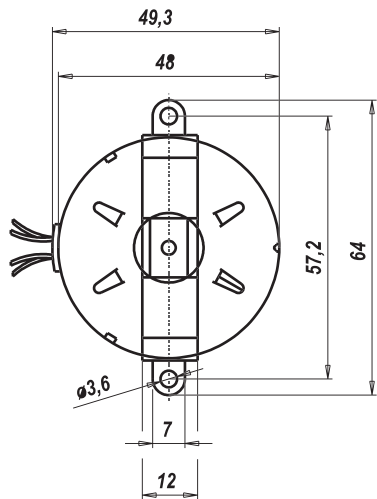

Mounting with screw clip
(item no. 4186 48080)

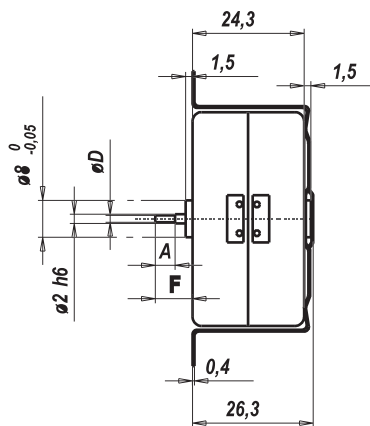

Mounting with snap-on clip
(item no. 4199 48040)

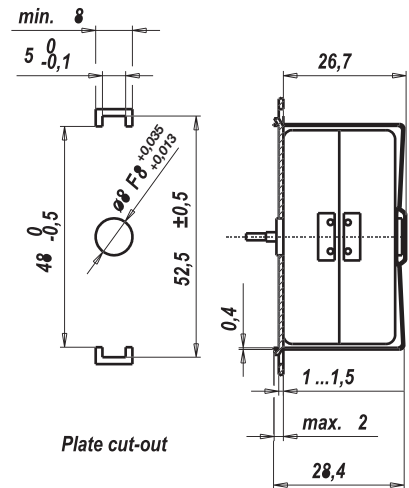

Plate cut-out

∅D Rotor shaft

∅ 1.5 js8 ^{+0,007}/_{-0,007}

∅ 2 h6 ⁰/_{-0,006}

Dimension A Dimension F

4,3 6,5

— 8,2

UFM

UFM1

Dimensions (mm)	Ø 52 x 28
Voltage (V)	12–230
Speed (rpm) 50 Hz	250
60 Hz	300
Pole number	24
Running torque (cNm)	
50 Hz	3.2
60 Hz	3.0
Power output (W)	
50 Hz	0.8
60 Hz	0.9
Gear combination	D, M, B, F, V, J (i ≤ 2k), O, P

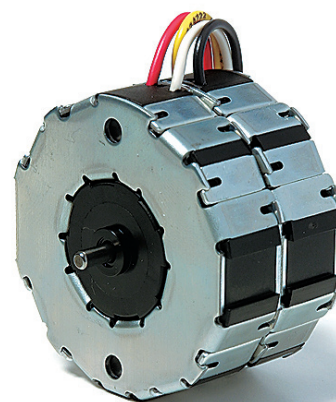

Rotational

Note: Running torque = Pull-out torque (starting motor at no load, then torque increase)
 Running torque and Power output are minimum values, at rated voltage and motor temperature 23°C

Standard Data

Climatic class	wide-spread according to DIN IEC 60721-2-1 : 2015
Ambient temperature operation	°C -15...+55
Ambient temperature storage	°C -20...+100
Thermal resistance at f=0 R _{therm}	13 K/W
Thermal class	105 (A) according to DIN EN 60085 : 2008 (130 / B on request)
Approval	standard (UL/CSA on request)
Mounting	any position
Electrical connection	lead wires AWG22, insulation Ø 1.72 ± 0.08 mm
Protection	IP40 according to DIN EN 60529 : 2014
Weight	180 g
Rotor stalling	motor can be stopped when voltage is applied, without being overheated
Bearings	sintered bronze, self-lubricating
Electric strength	according to DIN EN 60034-1/DIN EN 60335-1

Order Reference

Type	Synchronous Motor	UFM1	0	N	B4	R	N
Rotor shaft, mounting	0 centring 8 mm, shaft 3.0 mm, clip	E centring 10 mm, shaft 3.0 mm, screw plate					
	1 centring 8 mm, shaft 2.0 mm, clip	K centring 10 mm, shaft 2.0 mm, screw plate					
	2 centring 8 mm, shaft 1.5 mm, clip	M centring 10 mm, shaft 1.5 mm, screw plate					
	3 centring 8 mm, shaft 3.0 mm, screw plate	B centring 10 mm, shaft 3.0 mm, clip					
	4 centring 8 mm, shaft 2.0 mm, screw plate	A centring 10 mm, shaft 2.0 mm, clip					
	5 centring 8 mm, shaft 1.5 mm, screw plate	C centring 10 mm, shaft 1.5 mm, clip					
Approval	N Approval Standard						
Voltage/Frequency	See next page						
Direction	reversible						
Cable	N cable 150 mm (other on request)						

All specifications are representative only and maybe subject to variation. For confirmation of values, please contact Johnson Electric.
 Please also read "Saia Motors Important Notes" on catalog or at www.johnsonelectric.com/SaiaMotorsNotes



UFM

Technical Data

Rated frequency	Hz	50	60			
Speed n	rpm	250	300			
Power consumption	W	4	3.1			
Power output	W	0.8	0.9			
Running torque	cNm	3.2	3.0			
Rotor inertia J _R	gcm ²	14.4				
Detent torque M _s	cNm	0.38				
Tolerance of voltage		standard power supply system + 10% / - 10%				
Winding temperature T _{max}	°C	105				
Direction of rotation		reversible				
Rated voltage U _N	V	12	24	48	110-120	230
Duty cycle	%	100	100	100	100	100
Resistance R ₂₀	Ω	15	59	240	1390	5690
Capacitor C _n (50Hz, 60Hz)	μF/V ±10%	39;33/20	10;8.2/45	2.2;1.8/70	0.39;0.33/230	0.1;0.082/440
Winding code	50Hz/60Hz	B1/G1	B4/G4	C1/H1	D1/J1	D5/J5

Circuit diagram Parallel circuit

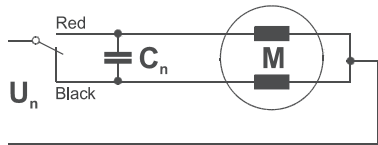

Red = clockwise rotation
Black = counter clockwise rotation

Dimensions

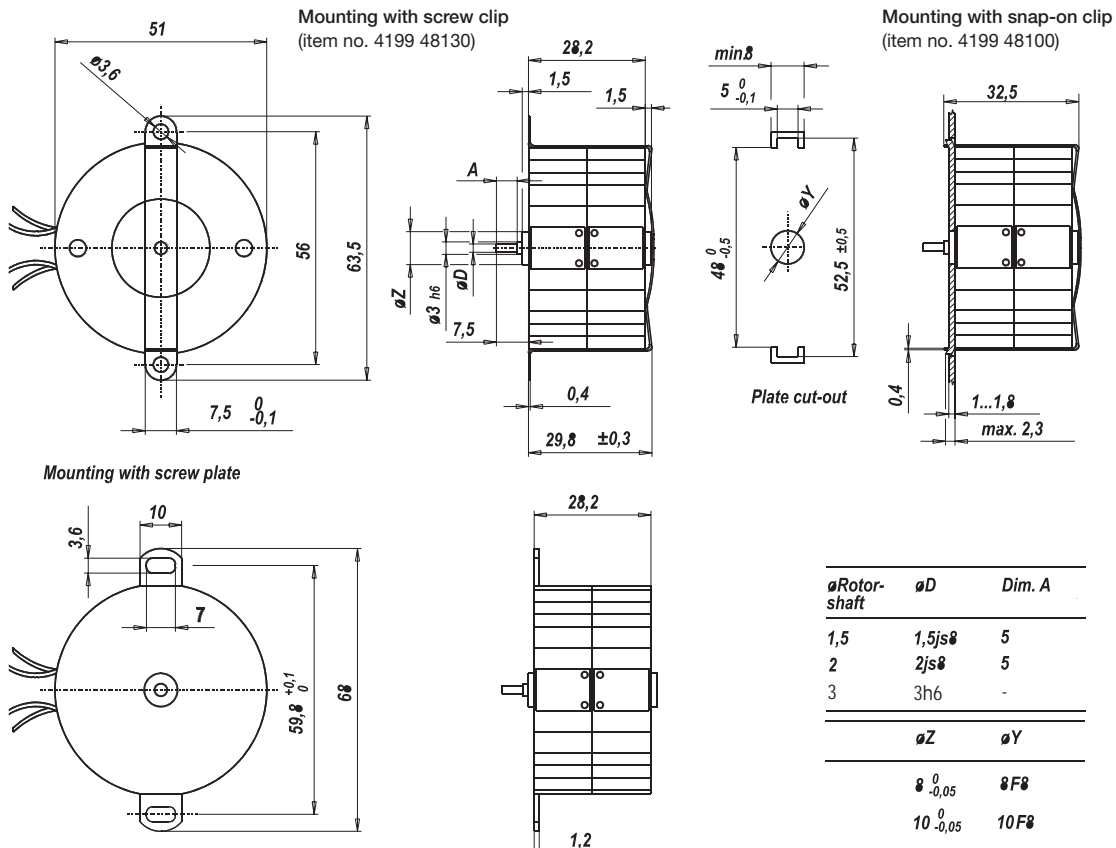

UFU

UFU1

Dimensions (mm)	∅ 52 x 28
Voltage (V)	24–230
Speed (rpm) 50 Hz	375
60 Hz	450
Pole number	16
Running torque (cNm)	
50 Hz	3.0
60 Hz	2.8
Power output (W)	
50 Hz	1.2
60 Hz	1.3
Gear combination	D, M, B, F, V, J (i ≤ 2k), O, P

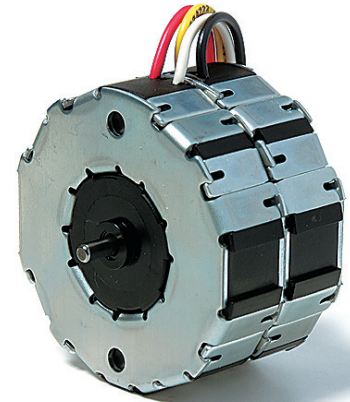

Rotational

Note: Running torque = Pull-out torque (starting motor at no load, then torque increase)
 Running torque and Power output are minimum values, at rated voltage and motor temperature 23°C

Standard Data

Climatic class	wide-spread according to DIN IEC 60721-2-1 : 2015
Ambient temperature operation	°C -15...+55
Ambient temperature storage	°C -20...+100
Thermal resistance at f=0 R _{therm}	13 K/W
Thermal class	105 (A) according to DIN EN 60085 : 2008 (130 / B on request)
Approval	standard
Mounting	any position
Electrical connection	cable
Protection	IP40 according to DIN EN 60529 : 2014
Weight	180 g
Rotor stalling	motor can be stopped when voltage is applied, without being overheated
Bearings	sintered bronze, self-lubricating
Electric strength	according to DIN EN 60034-1/DIN EN 60335-1

Order Reference

Type	Synchronous Motor	UFU1	00	N	B4	R	N
Rotor shaft, mounting	0 centring 8 mm, shaft 3.0 mm, clip	E centring 10 mm, shaft 3.0 mm, screw plate					
	1 centring 8 mm, shaft 2.0 mm, clip	K centring 10 mm, shaft 2.0 mm, screw plate					
	2 centring 8 mm, shaft 1.5 mm, clip	M centring 10 mm, shaft 1.5 mm, screw plate					
	3 centring 8 mm, shaft 3.0 mm, screw plate	B centring 10 mm, shaft 3.0 mm, clip					
	4 centring 8 mm, shaft 2.0 mm, screw plate	A centring 10 mm, shaft 2.0 mm, clip					
	5 centring 8 mm, shaft 1.5 mm, screw plate	C centring 10 mm, shaft 1.5 mm, clip					
		D centring 12 mm, shaft 3.0 mm, clip					
Approval	N Approval Standard						
Voltage/Frequency	See next page						
Direction	reversible						
Cable	N cable 150 mm (other on request)						

All specifications are representative only and maybe subject to variation. For confirmation of values, please contact Johnson Electric.
 Please also read "Saia Motors Important Notes" on catalog or at www.johnsonelectric.com/SaiaMotorsNotes



UFU

Technical Data

Rated frequency	Hz	50	60	
Speed n	rpm	375	450	
Power consumption	W	3.2	3.5	
Power output	W	1.2	1.3	
Running torque	cNm	3.0	2.8	
Rotor inertia J _R	gcm ²	14.4		
Detent torque M _s	cNm	0.38		
Tolerance of voltage		standard power supply system + 10% / - 10%		
Winding temperature T _{max}	°C	105		
Direction of rotation		reversible		
Rated voltage U _N	V	24	110	230
Duty cycle	%	100	100	100
Resistance R ₂₀	Ω	95	2200	8400
Capacitor C _n (50Hz, 60Hz)	μF/V ±10%	10;8.2/48	0.47;0.39/220	0.1;0.082/460
Winding code	50Hz/60Hz	B4/G4	C8/H8	D5/J5

Circuit diagram Parallel circuit

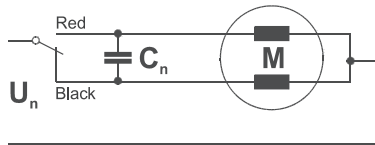

Red = clockwise rotation
Black = counter clockwise rotation

Dimensions

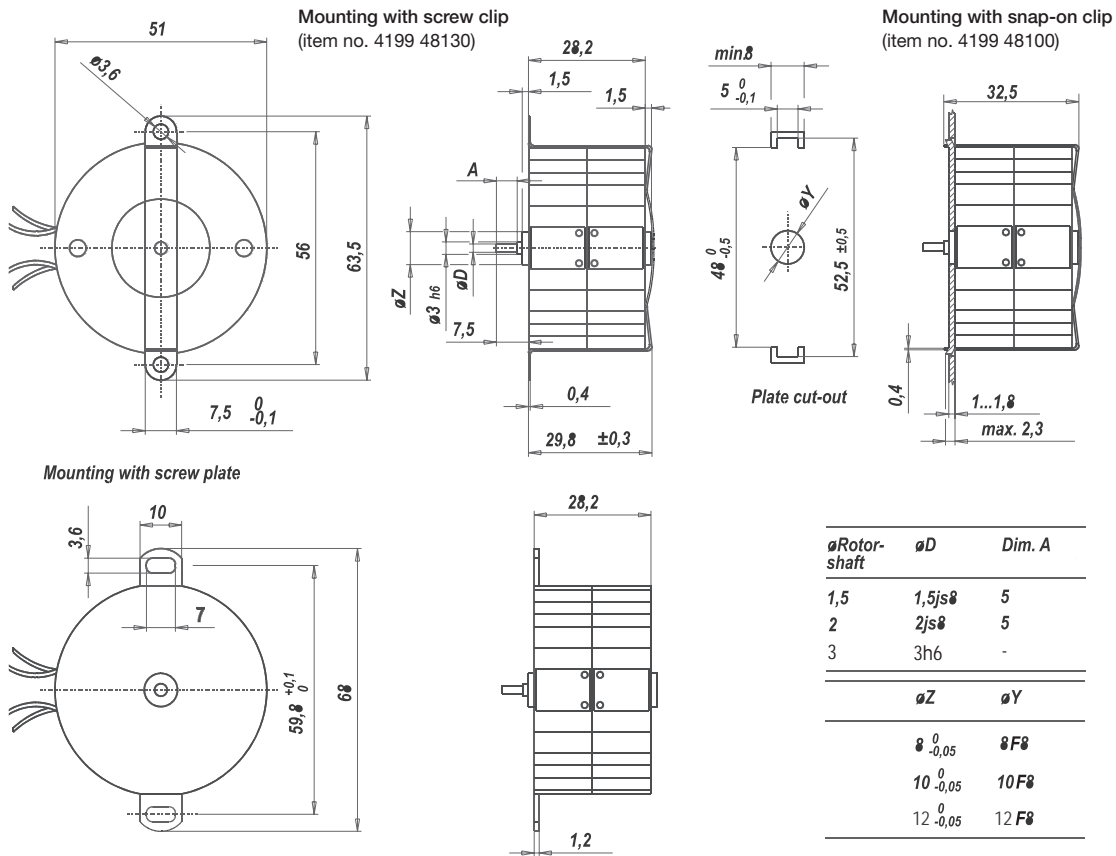

Lead wires: AWG 22 (0.34 mm²), insulation diameter Ø1.72 ±0.08 mm, 6 mm stripped

UFR

UFR1/UFR3/UFR4

Dimensions (mm) Ø 52 x 28 / Ø 52 x 42 / Ø 52 x 56

Voltage (V) 12–230

Speed (rpm) 50 Hz 500
60 Hz 600

Pole number 12

Running torque (cNm)
50 Hz 2.4 / 3.1 / 4.5
60 Hz 2.2 / 2.6 / 4.0

Power output (W)
50 Hz 1.3 / 1.6 / 2.4
60 Hz 1.4 / 1.6 / 2.5

Gear combination D, M, B, F, V, J ($i \leq 2k$), O, P

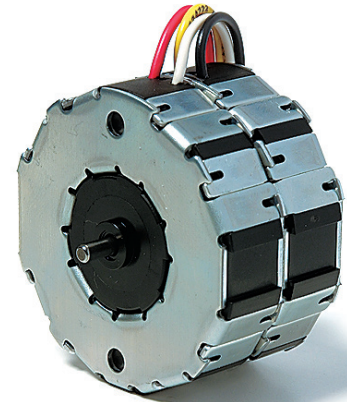

UFR1

Note: Running torque = Pull-out torque (starting motor at no load, then torque increase)
Running torque and Power output are minimum values, at rated voltage and motor temperature 23°C

Standard Data

Climatic class	wide-spread according to DIN IEC 60721-2-1 : 2015
Ambient temperature operation	°C -15...+55
Ambient temperature storage	°C -20...+100
Thermal resistance at f=0 R _{therm}	11 K/W (UFR1), 7 K/W (UFR4)
Thermal class	105 (A) according to DIN EN 60085 : 2008 (130 / B on request)
Approval	standard (UL/CSA on request)
Mounting	any position
Electrical connection	lead wires AWG22, insulation Ø 1.72 ± 0.08 mm
Protection	IP40 according to DIN EN 60529 : 2014
Weight	180 g (UFR1), 370 g (UFR4)
Rotor stalling	motor can be stopped when voltage is applied, without being overheated
Bearings	sintered bronze, self-lubricating
Electric strength	according to DIN EN 60034-1/DIN EN 60335-1

Order Reference

Type	Synchronous Motor	UFR	1	0	N	B4	R	N
Configuration	1 Two coils 3 Three coils 4 Four coils							
Rotor shaft, mounting	0 centring 8 mm, shaft 3.0 mm, clip 1 centring 8 mm, shaft 2.0 mm, clip 2 centring 8 mm, shaft 1.5 mm, clip 3 centring 8 mm, shaft 3.0 mm, screw plate* 4 centring 8 mm, shaft 2.0 mm, screw plate* 5 centring 8 mm, shaft 1.5 mm, screw plate*	B centring 10 mm, shaft 3.0 mm, clip A centring 10 mm, shaft 2.0 mm, clip C centring 10 mm, shaft 1.5 mm, clip D centring 12 mm, shaft 3.0 mm, clip E centring 10 mm, shaft 3.0 mm, screw plate* K centring 10 mm, shaft 2.0 mm, screw plate* M centring 10 mm, shaft 1.5 mm, screw plate*						
Approval	N Approval Standard							
Voltage/Frequency	See next page							
Direction	reversible							
Cable	N cable 150 mm (other on request)							

* screw plate not for UFR3 and UFR4

All specifications are representative only and maybe subject to variation. For confirmation of values, please contact Johnson Electric.
Please also read "Saia Motors Important Notes" on catalog or at www.johnsonelectric.com/SaiaMotorsNotes



UFR

Technical Data

UFR1	Rated frequency	Hz	50	60			
	Speed n	rpm	500	600			
	Power output P _{mech}	W	1.3	1.4			
	Running torque M _n	cNm	2.4	2.2			
	Power consumption P _{el}	W	3.3	3.6			
	Detent torque M _s	cNm	0.39				
	Rotor inertia J _R	gcm ²	14.2				
	Rated voltage U _N	V	12	24	48	110	230
	Duty cycle	%	100	100	100	100	100
	Resistance R ₂₀	Ω	27	105	400	2400	9100
	Capacitor C _n (50Hz, 60Hz)	μF/V ±10%	39;33/24	10;8.2/45	2.7;2.2/90	0.47;0.39/230	0.12;0.10/440
	Winding code	50Hz/60Hz	B1/G1	B4/G4	C1/H1	C8/H8	D5/J5
	UFR3	Rated frequency	Hz	50	60		
Speed n		rpm	500	600			
Power output P _{mech}		W	1.6	1.6			
Running torque M _n		cNm	3.1	2.6			
Power consumption P _{el}		W	6.1	5.1			
Detent torque M _s		cNm	0.46				
Rotor inertia J _R		gcm ²	17				
Rated voltage U _N		V	12	24	48	110	230
Duty cycle		%	100	100	100	100	100
Resistance R ₂₀		Ω	19	70	280	1520	5850
Capacitor C _n (50Hz, 60Hz)		μF/V ±10%	150;100/12	39;27/24	10;6.8/48	1.8;1.2/110	0.47;0.33/230
Winding code		50Hz/60Hz	B1/G1	B4/G4	C1/H1	C8/H8	D5/J5
UFR4		Rated frequency	Hz	50	60		
	Speed n	rpm	500	600			
	Power output P _{mech}	W	2.4	2.5			
	Running torque M _n	cNm	4.5	4.0			
	Power consumption P _{el}	W	6.4	6.9			
	Detent torque M _s	cNm	0.68				
	Rotor inertia J _R	gcm ²	24.2				
	Rated voltage U _N	V	24	48	110	230	
	Duty cycle	%	100	100	100	100	
	Resistance R ₂₀	Ω	56	210	1200	4800	
	Capacitor C _n (50Hz, 60Hz)	μF/V ±10%	18;15/45	4.7;3.9/90	0.82;0.68/200	0.22;0.18/400	
	Winding code	50Hz/60Hz	B4/G4	C1/H1	C8/H8	D5/J5	
	Tolerance of voltage		standard power supply system + 10% ... - 10%				
Winding temperature T _{max}	°C	105					
Direction of rotation		reversible					

Circuit diagram UFR1 Parallel circuit

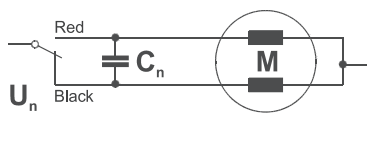

UFR3 Parallel circuit

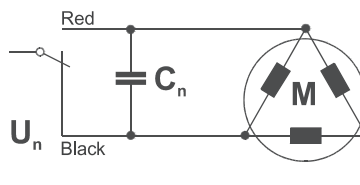

UFR4 Parallel circuit

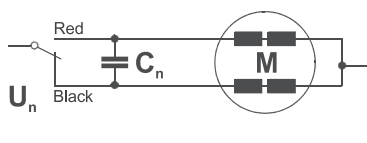

Red = clockwise rotation
Black = counter clockwise rotation

UFR

Dimensions

UFR1

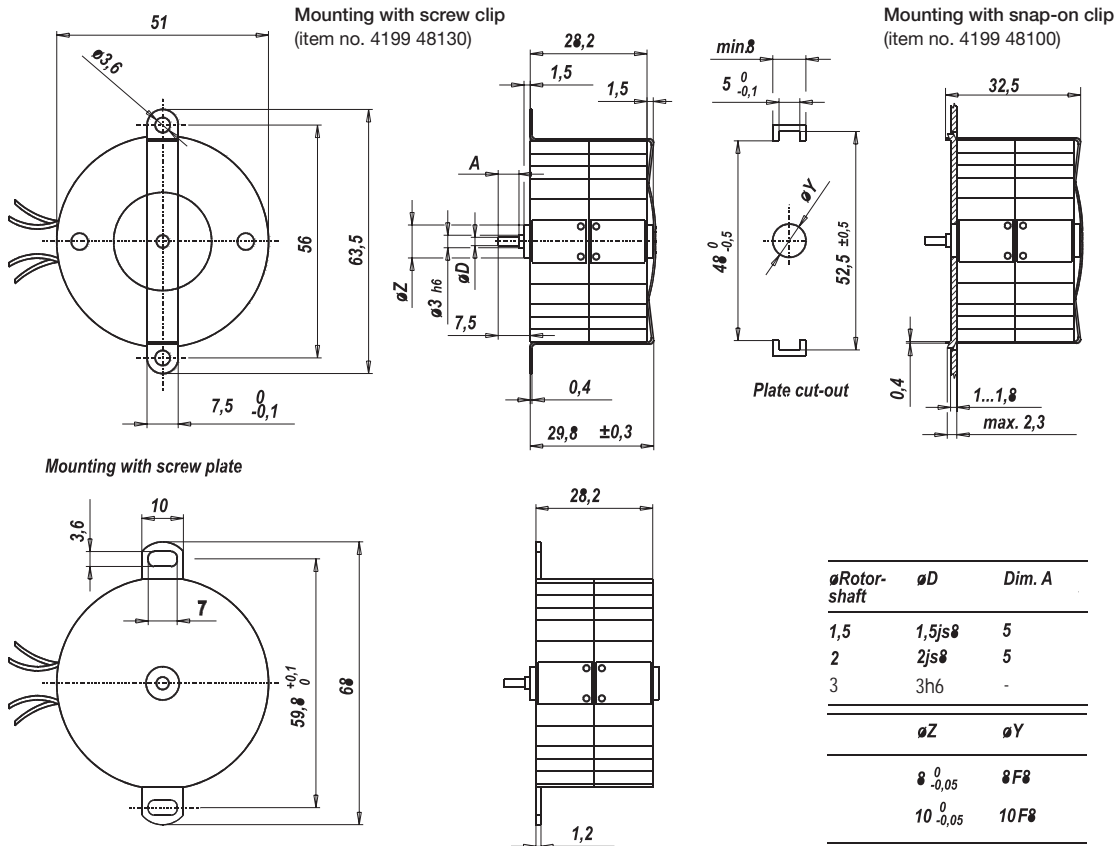

UFR3

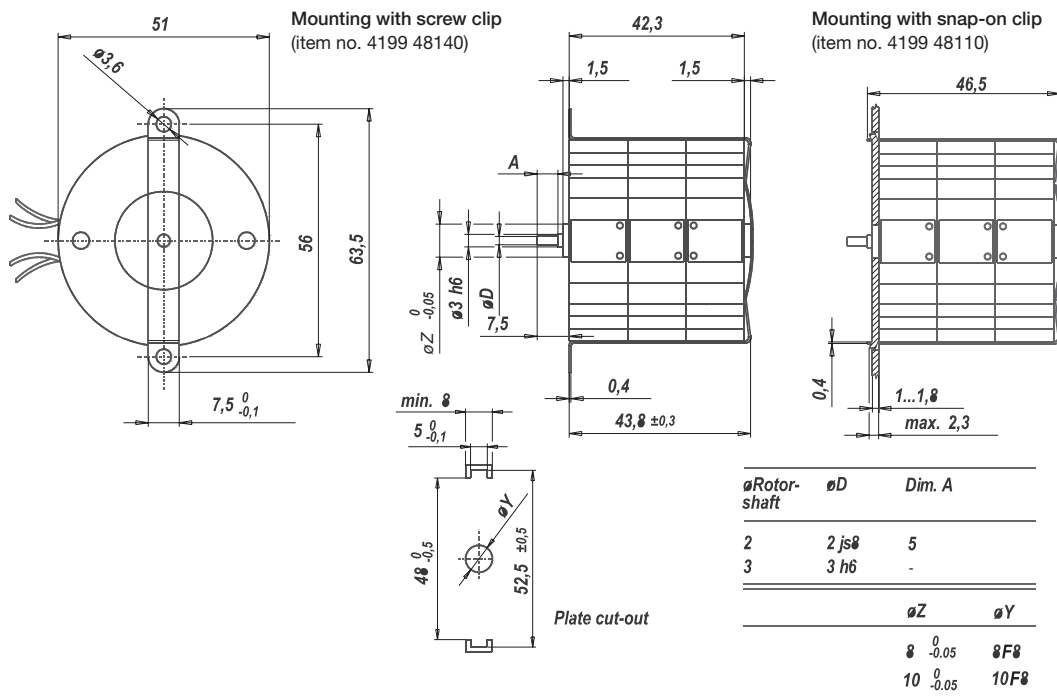

UFR

Dimensions
UFR4

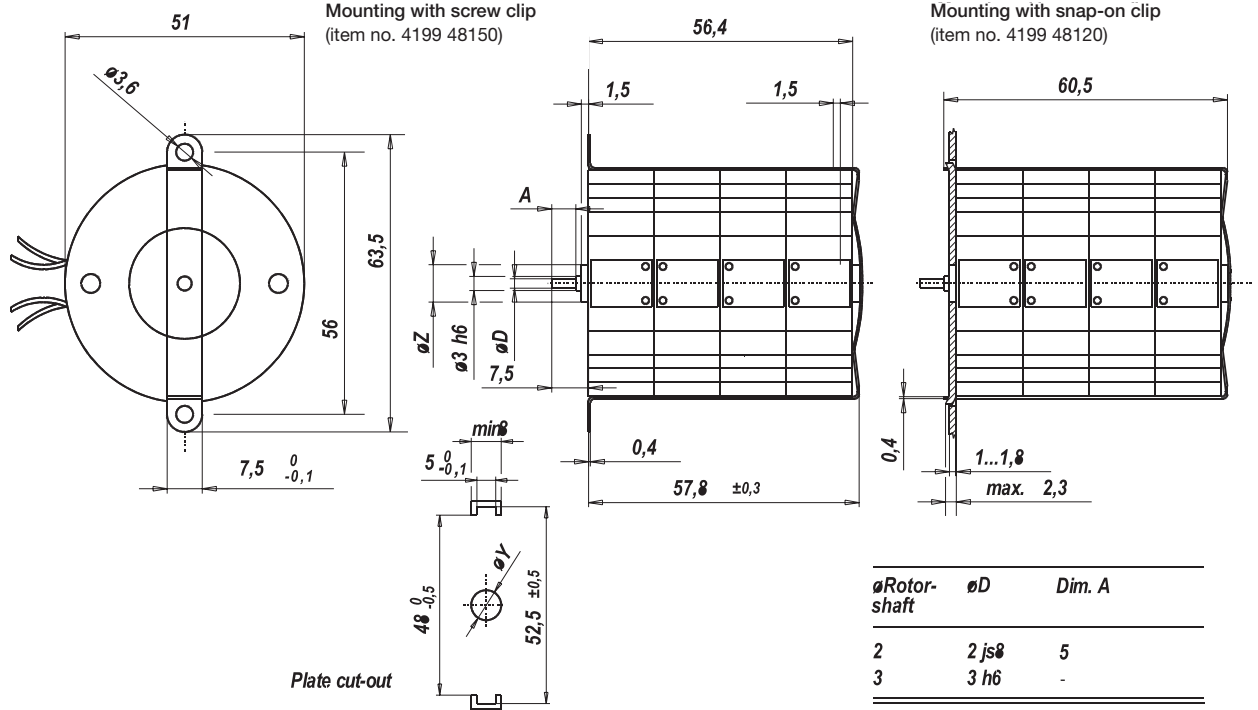

ϕ Rotor-shaft	ϕD	Dim. A
2	2 js8	5
3	3 h6	-

ϕZ	ϕY
8 $\begin{smallmatrix} 0 \\ -0.05 \end{smallmatrix}$	8F8
10 $\begin{smallmatrix} 0 \\ -0.05 \end{smallmatrix}$	10F8

UPU

UP (SM6443; SM6444)

Dimensions (mm)	∅ 64 x 43
Voltage (V)	12–230
Speed (rpm) 50 Hz	375
60 Hz	450
Pole number	16
Running torque (cNm) 50 Hz	11.1–15.2 (UPU1); 26.0–30.4 (UPU5)
60 Hz	9.0–14.5 (UPU1); 21–25.5 (UPU5)
Power output (W) 50 Hz	4.4–6.0 (UPU1); 10.2–11.9 (UPU5)
60 Hz	4.2–6.8 (UPU1); 9.9–12.0 (UPU5)
Gear combination	O, P, R

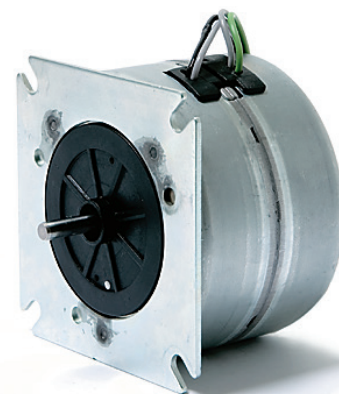

Rotational

Note: Running torque = Pull-out torque (starting motor at no load, then torque increase)
Running torque and Power output are minimum values, at rated voltage and motor temperature 23°C

Standard Data

Climatic class	wide-spread according to DIN IEC 60721-2-1 : 2015
Ambient temperature operation	°C -15 ... +40
Ambient temperature storage	°C -20 ... +100
Thermal class	130 (B) according to DIN EN 60085 : 2008
Approval	standard
Mounting	any position
Electrical connection	lead wires AWG22, insulation ∅ 1.6 ± 0.1 mm
Protection	IP30 according to DIN EN 60529 : 2014
Weight	500 g (UPU1); 550 g (UPU5)
Rotor stalling	motor can be stopped when voltage is applied, without being overheated
Bearings	Sintered bronze, self-lubricating

Order Reference

Type	Synchronous Motor	UPU	1	1	N	B4	R	E
Configuration	1 standard magnet 5 stronger magnet							
Rotor shaft, mounting	1 centring 10 mm, shaft length 8,1 mm, screw plate 2 centring 10 mm, shaft length 15,5 mm, screw plate A centring 14 mm, shaft length 8,1 mm, screw plate C centring 14 mm, shaft length 15,5 mm, screw plate							
Approval	N standard							
Voltage/Frequency	see next page							
Direction	R reversible							
Cable	E 150 mm (other upon request)							

All specifications are representative only and maybe subject to variation. For confirmation of values, please contact Johnson Electric.
Please also read "Saia Motors Important Notes" on catalog or at www.johnsonelectric.com/SaiaMotorsNotes



UPU

Technical Data

UPU1		Standard			S2 version (Z20)	
		Rated frequency	Hz	50	60	50
Speed	rpm	375	450	375	450	
Running torque Mn	cNm	11.1	9.0	15.2	14.5	
Power output	W	4.4	4.2	6.0	6.8	
Power consumption	VA	10.5	13.4	16.8	19.4	
Detent torque MS	cNm	1.7	1.7	1.7	1.7	
Winding temperature increase	K	95	100	90 (S2 20 min)		
Weight	g	500	500	500	500	
Standard windings						
Rated voltage U_N	V	24	115	230		
Duty cycle	%	100	100	100		
Resistance R_{20}	Ω	26	560	2450		
Capacitor C(50/60 Hz)	$\mu F \pm 10\%/V$	30/63	1,3/250	0,33/500		
Winding code		B4/G4	D0/J0	D5/J5		
UPU5		Special version (Z21)			Standard	
		Rated frequency	Hz	50	60	50
Speed	rpm	375	450	375	450	
Running torque Mn	cNm	26.0	21.0	30.4	25.5	
Power output	W	10,2	9,9	11.9	12.0	
Power consumption	VA	26	28	26.3	33,5	
Detent torque MS	cNm	6	6	6	6	
Winding temperature increase	K	85 (S2 6,5 min)	85 (S2 6,5 min)	95 (S2 5 min)	95 (S2 5 min)	
Weight	g	550	550	550	550	
Standard windings						
Rated voltage U_N	V	24	48	115	230	
Duty cycle	%					
Resistance R_{20}	Ω	9,5	37	230	810	
Capacitor C(50/60 Hz)	$\mu F \pm 10\%/V$	82/63	20/160	3,3/250	0,82/500	
Winding code		B4/G4	C1/H1	D0/J0	D5/J5	

Circuit diagram Clockwise rotation

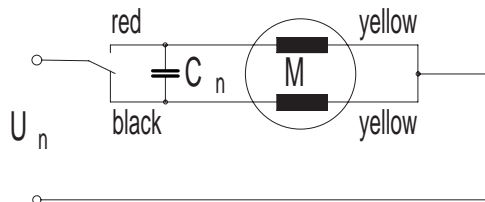

Dimensions mounting dimensions UP with screw plate

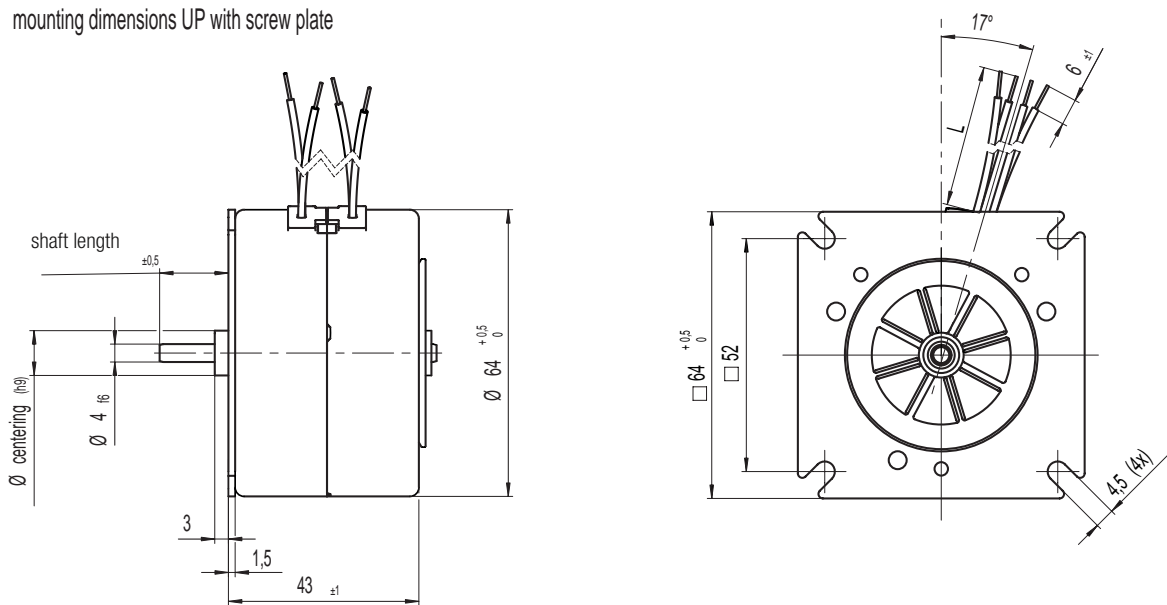
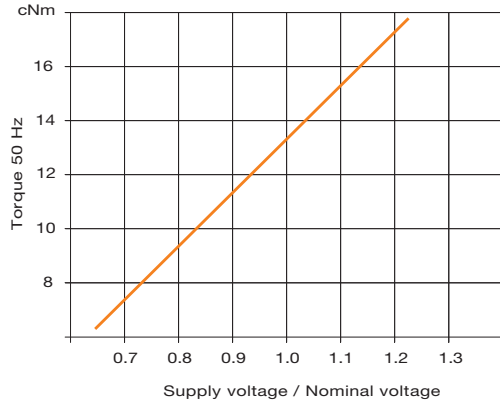

Chart: Torque versus Voltage

UPU1



UPU1 S2 version (Z20)

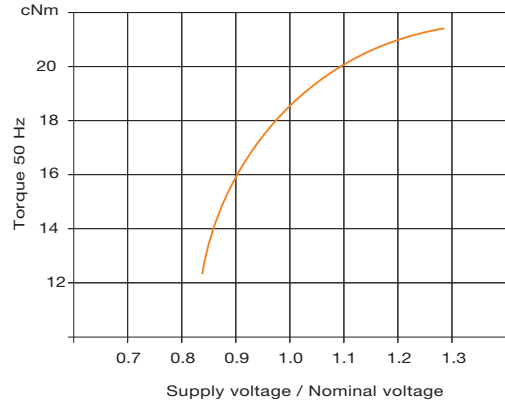
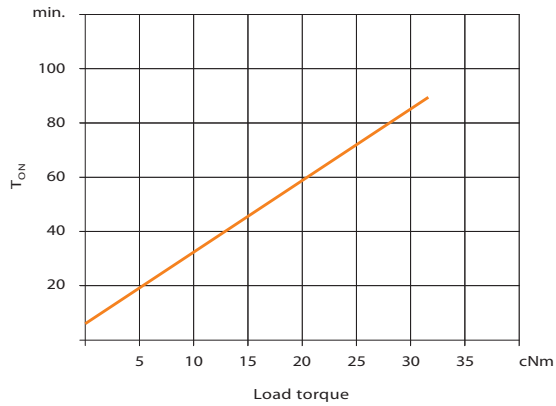

Chart: Possible S2 ON time versus load torque

UPU5 special version (Z21)



UPU5 standard

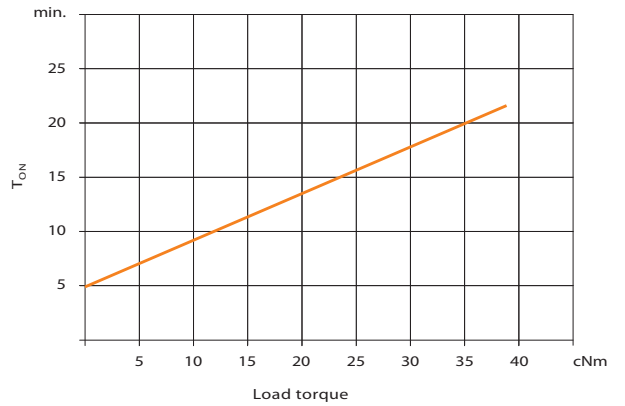
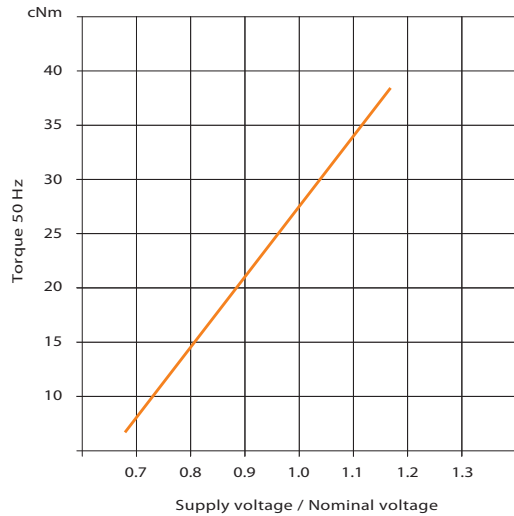
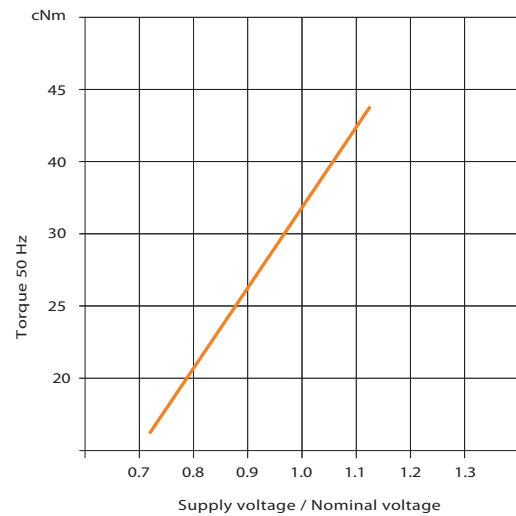

Chart: Torque versus Voltage

UPU5 special version (Z21)



UPU5 standard



Connection Types UC motors

Connector B
for Molex Mini-Grid 51110-0660

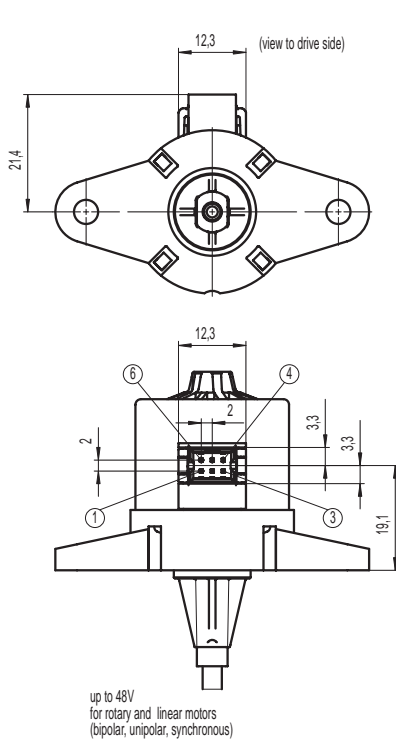

Connector C
for Tyco Modu IV 0-1740209-6

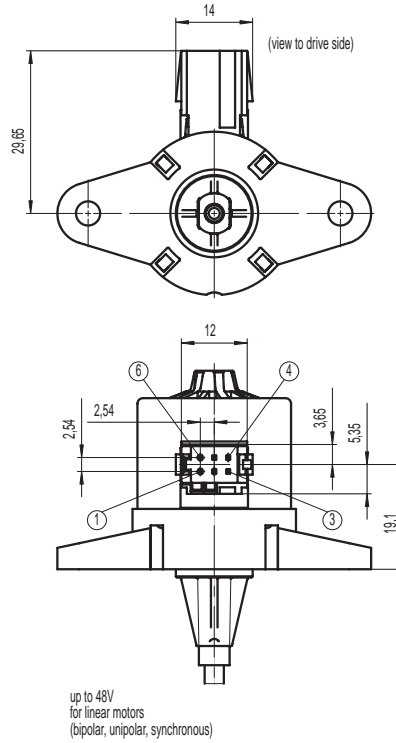

Connector D
for Molex C-Grid III 90142-0006

