



# 1.27 mm SMC Board-to-Board Adapter



---

[www.erni.com](http://www.erni.com)

## 1.27 mm SMC Board-to-Board Adapter



The SMC Board-to-Board-Adapter is an exciting addition to the extensive SMC 1.27mm (.050") pitch connector line, offering impressive flexibility in its board-to-board heights ranging from 20 mm to 40 mm in 2 mm increments.

Available in 12, 26 and 50 pins, the SMC Adapter has male contacts on both component ends, and securely locks into a female SMC connector for a robust assembled solution.

To protect the daughter card from handling mishaps, the SMC Adapter can be attached during the end-of-assembly process.

### Features

- Number of pins: 12, 26, 50
- Pitch: 1.27 mm
- Board-to-board height with female connectors (6.25 mm):  
20-38 mm (by utilization of the wipe length, continuously variable board-to-board heights of 20-40 mm)
- Male connectors on both sides
- Tray packaging
- Robust interlocking on one side

# 1.27 mm SMC Board-to-Board Adapter

## Mating Conditions

### Mating Principle

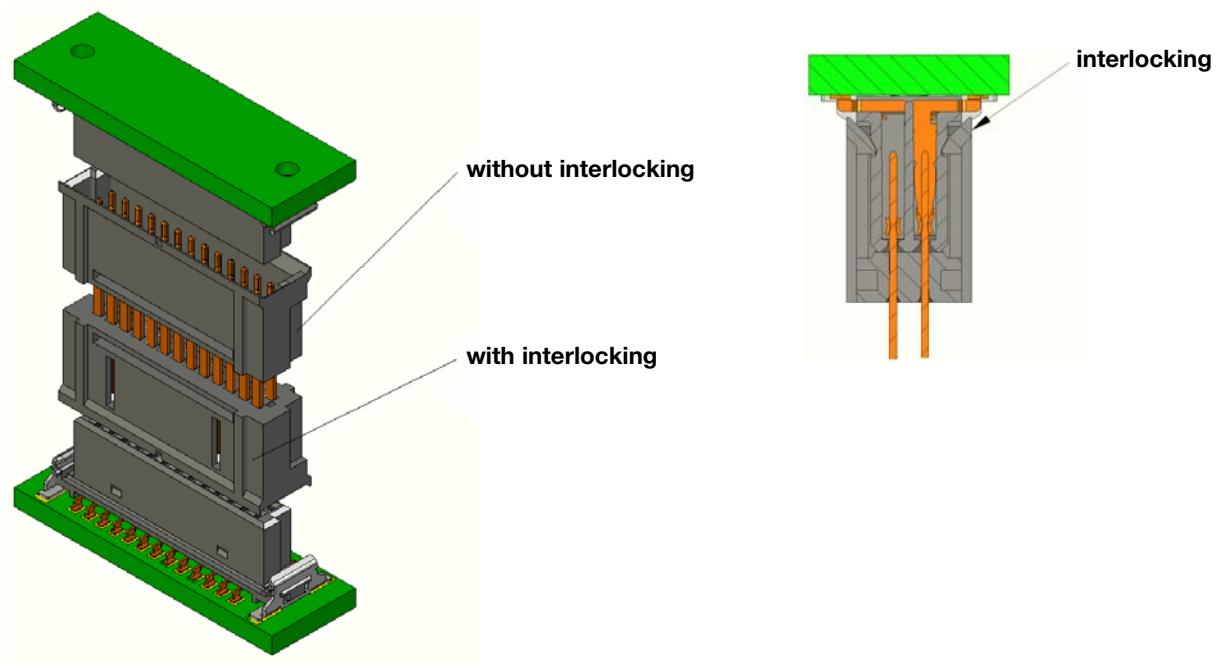

### Board-to-Board Height

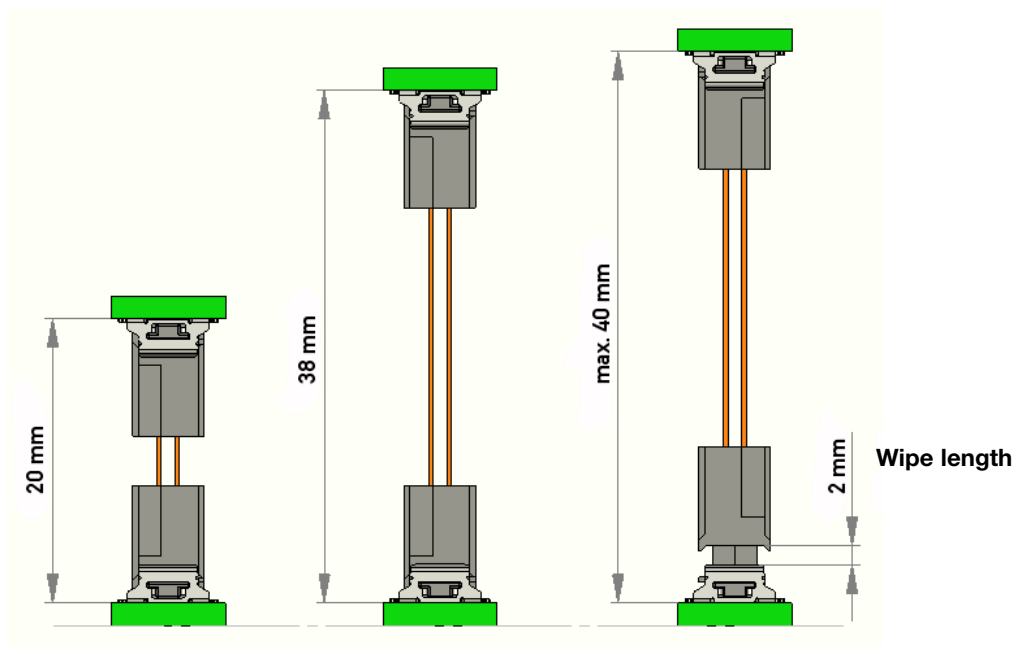

Notice:  
PCBs have to be secured by spacers.

## 12 pin Versions

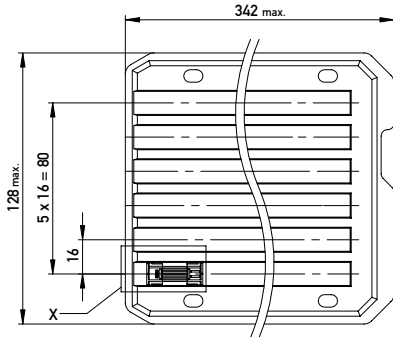

Einzelheit X (M 2:1)  
*detail X*

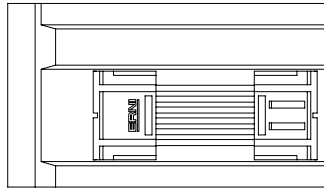

## 26 pin Versions

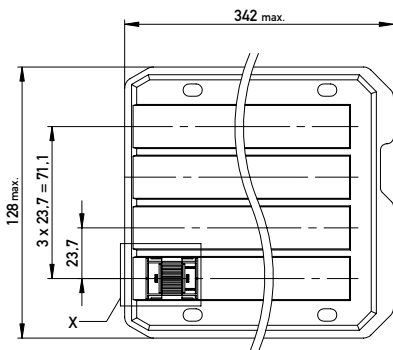

Einzelheit X (M 2:1)  
*detail X*

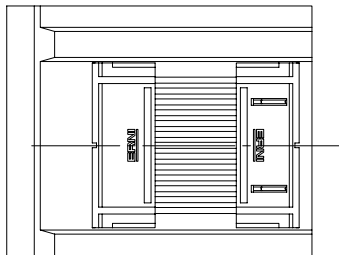

## 50 pin Versions

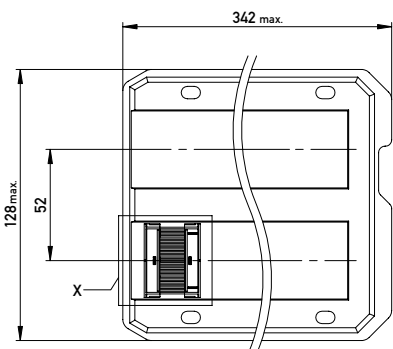

Einzelheit X (M 2:1)  
*detail X*

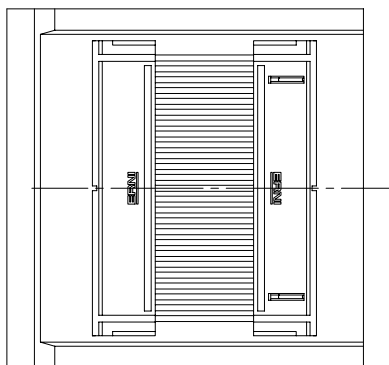



## 1.27 mm SMC Board-to-Board Adapter

### Electrical and Mechanical Characteristics

	<b>Standard</b>	<b>Board-to-Board Adapter</b>
Number of Pins		12, 26, 50
<b>Housing materials</b>		
Plastic material (symbol)		LCP
CTI value	IEC 112	CTI 175
UL flame rating		UL 94 V-0
UL file		E 83005
<b>Contact materials</b>		
Base material		Cu alloy
Mating area		Gold plating
<b>Environment compatibility</b>		
Recycling		no flame-retardent additives, no toxic additives allows easy recycling
<b>Product-approval</b>		
UL		E 84703

# 1.27 mm SMC Board-to-Board Adapter

## 12 pin Versions

### Dimensional Drawing

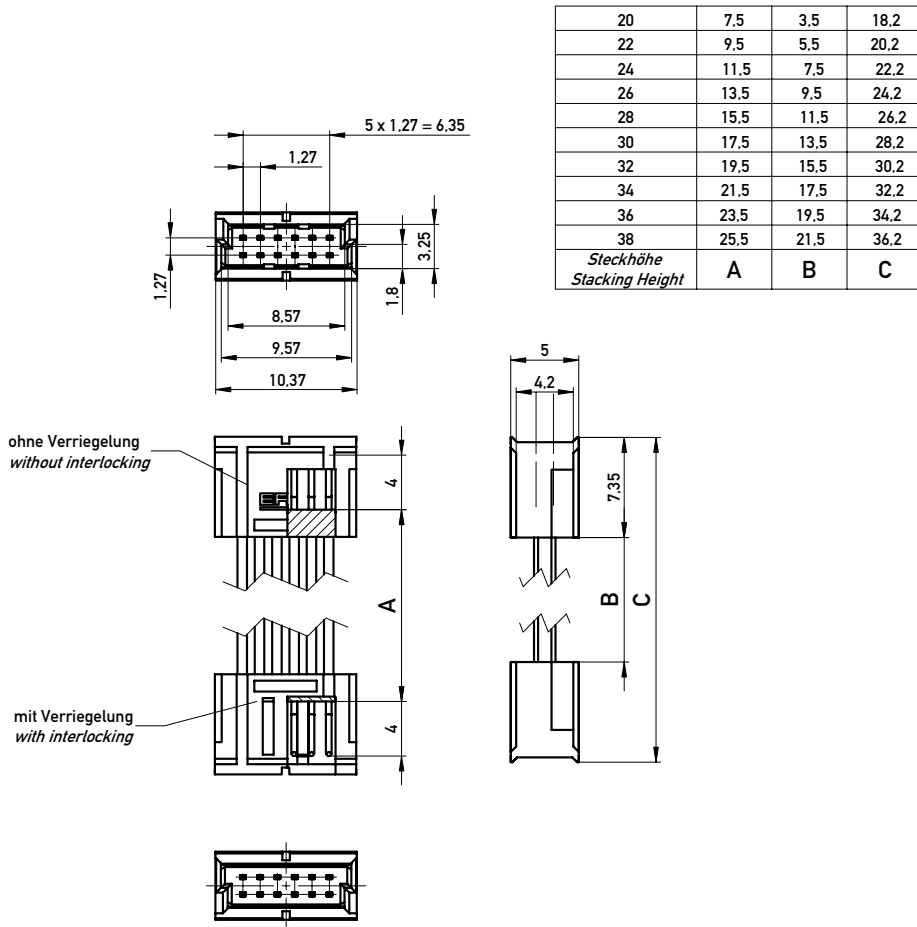

### Ordering Information

Number of Pins	Board-to-Board Height, mated	Suitable Female Connector, Part Number	Packaging	Part Number
12	20 mm	154805	Tray/102 pcs	364094
12	22 mm	154805	Tray/90 pcs	364095
12	24 mm	154805	Tray/84 pcs	364096
12	26 mm	154805	Tray/78 pcs	364097
12	28 mm	154805	Tray/72 pcs	364098
12	30 mm	154805	Tray/66 pcs	364099
12	32 mm	154805	Tray/60 pcs	364100
12	34 mm	154805	Tray/54 pcs	364101
12	36 mm	154805	Tray/54 pcs	364102
12	38 mm	154805	Tray/48 pcs	364103

### Dimensional Drawing

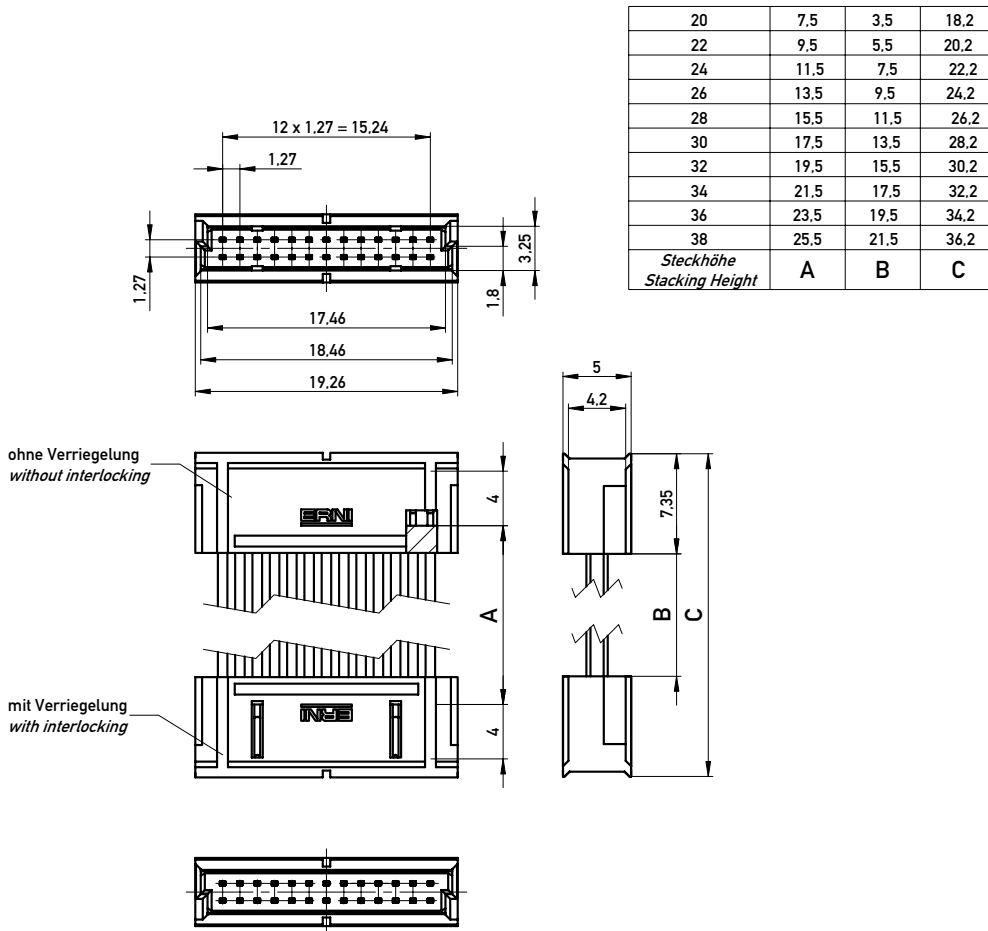

### Ordering Information

Number of Pins	Board-to-Board Height, mated	Suitable Female Connector, Part Number	Packaging	Part Number
26	20 mm	154806	Tray/68 pcs	364084
26	22 mm	154806	Tray/60 pcs	364085
26	24 mm	154806	Tray/56 pcs	364086
26	26 mm	154806	Tray/52 pcs	364087
26	28 mm	154806	Tray/48 pcs	364088
26	30 mm	154806	Tray/44 pcs	364089
26	32 mm	154806	Tray/40 pcs	364090
26	34 mm	154806	Tray/36 pcs	364091
26	36 mm	154806	Tray/36 pcs	364092
26	38 mm	154806	Tray/32 pcs	364093

# 1.27 mm SMC Board-to-Board Adapter

## 50 pin Versions

### Dimensional Drawing

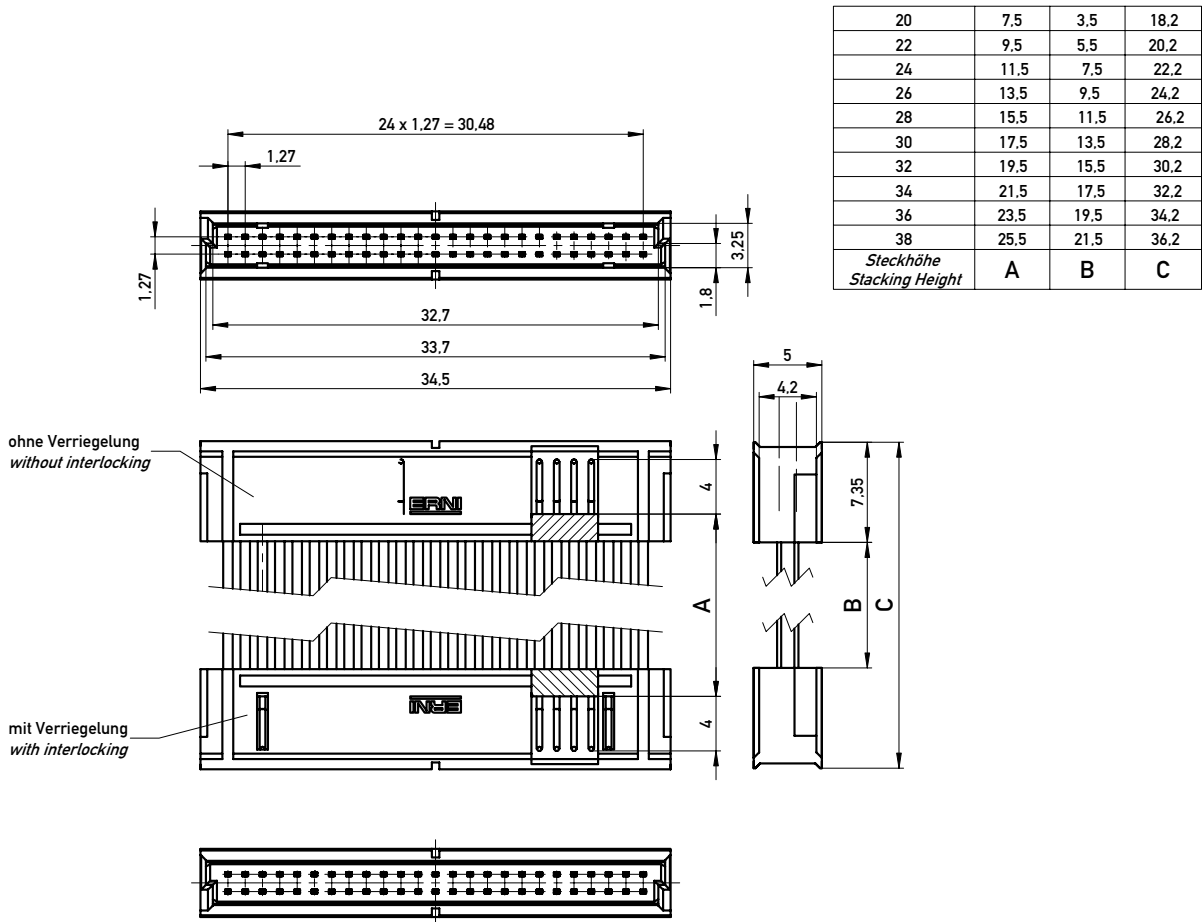

### Ordering Information

Number of Pins	Board-to-Board Height, mated	Suitable Female Connector, Part Number	Packaging	Part Number
50	20 mm	154807	Tray/34 pcs	354307
50	22 mm	154807	Tray/30 pcs	354308
50	24 mm	154807	Tray/28 pcs	354309
50	26 mm	154807	Tray/26 pcs	354310
50	28 mm	154807	Tray/24 pcs	354311
50	30 mm	154807	Tray/22 pcs	354312
50	32 mm	154807	Tray/20 pcs	354313
50	34 mm	154807	Tray/18 pcs	354314
50	36 mm	154807	Tray/18 pcs	354315
50	38 mm	154807	Tray/16 pcs	354316



Member



VMEbus INTERNATIONAL TRADE ASSOCIATION



**ERNI Electronics GmbH**

Seestrasse 9  
73099 Adelberg, Deutschland  
Tel +49 (0)71 66 50-0  
Fax +49 (0)71 66 50-282  
info@erni.de

Europe South America Africa Japan

**ERNI Electronics, Inc.**

3005 E. Boundary Terrace  
Midlothian, VA 23112  
Tel +1 (804) 228-4100  
Fax +1 (804) 228-4099  
info.usa@erni.com

North America Canada Mexico

**ERNI Asia Holding Pte Ltd.**

Blk 4008 Ang Mo Kio Avenue 10  
#04-01/02 Techplace I  
Singapore 569625  
Tel +65 6 555 5885  
Fax +65 6 555 5995  
info@erni-asia.com

Asia

[www.erni.com](http://www.erni.com)

© ERNI Electronics GmbH 2008 • Printed in Germany. A policy of continuous improvement is followed and the right to alter any published data without notice is reserved.  
ERNI®, MicroStac®, MicroSpeed®, MiniBridge®, MaxiBridge®, ERmet®, ERmet ZD®, ERbic® and ERNIPRESS® are trademarks (registered or applied for in various countries) of ERNI Electronics GmbH. AdvancedTCA®, CompactPCI® and CompactPCI Express® are trademarks of PCI Industrial Computer Manufacturers Group.