



- Connectorized housing
- Shallow mounting depth <1.00"
- 1, 2 and 3 axis configurations
- Voltage regulator, 24V supply option
- USB 2.0 HID interface options
- CAN bus J1939 and CANopen options

MECHANICAL (FOR X, Y AXIS)

- Break Out Force: 1.3N (0.3lbf)
- Operating Force: 2.8N (0.63lbf)
- Maximum Applied Force: 200N (45.00lbf)
- Mechanical Angle of Movement: 36° (18° from center)
- Expected Life: 5 million
- Material: Glass filled nylon
- Package Size: 5.75" x 4.50" x 3.25"
- Lever Action: Single spring, omnidirectional

ENVIRONMENTAL

- Operating Temperature: -40°C to 85°C (-40°F to 185°F)
- Storage Temperature: -40°C to 85°C (-40°F to 185°F)
- Sealing (IP): Up to IP68*
- EMC Immunity Level (V/M): EN61000-4-3
- EMC Emissions Level: EN61000-6-3:2001
- ESD: EN61000-4-2
- Output linearity: ±200mV
- Dual output interlinearity (X/Y): ±400mV
- Dual output interlinearity (Z): ±600mV

MECHANICAL (FOR Z AXIS)

- Break Out Torque: 0.09Nm (0.80lbf in)
- Operating Torque: 0.121Nm(1.07lbf in)
- Maximum Allowable Torque: 2.50Nm(22.13lbf in)
- Hand Mechanical Angle: 60° (30° from center)
- Handle Action: Spring centering, rotational
- Expected Life: 5 million

SENSOR SPECIFICATIONS

- Sensor: Hall effect, single or dual
- Supply Voltage Range: 5VDC ±0.01VDC
- Supply Current: 40mA typical / 50mA max (3 axis)
- Reverse Polarity Max: -10VDC
- Transient Overvoltage Max: 16VDC
- Ratiometric Output Voltage: See options
- Output Current: 8mA
- Output Load: 1K ohm min.
- Output Impedance: 2Ω

NOTES:

- All values are nominal.
- Exact specifications may be subject to configuration. Contact Technical Support for the performance of your specific configuration.
- * Excludes some handle options.



HF series

Hall effect joysticks

Overview



Distribución de componentes eléctricos y electrónicos

Tel.: (+34) 902 450 160
 Fax: (+34) 902 433 088
ermec@ermec.com
www.ermec.com

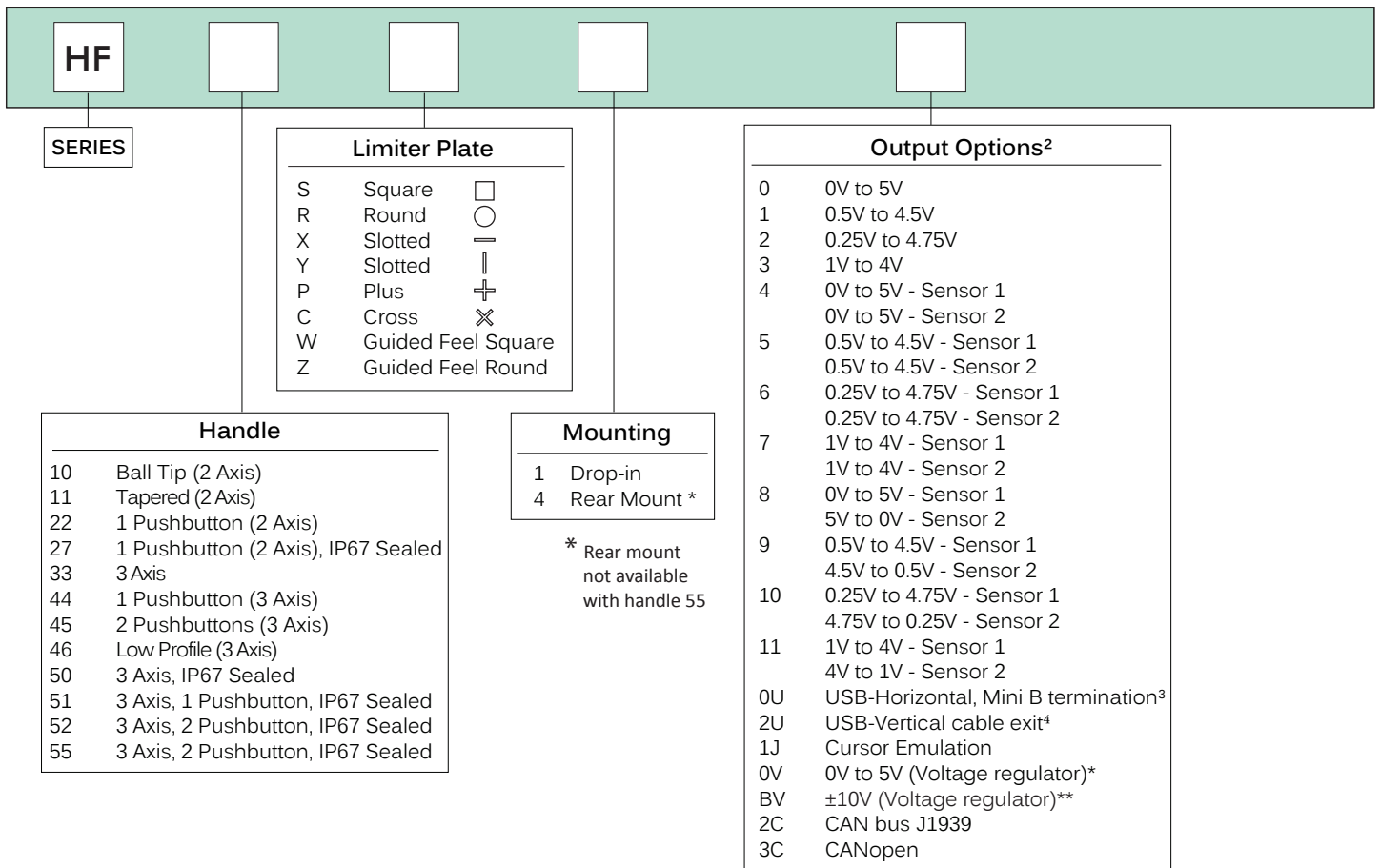

NOTES

- The HF Series joysticks are supplied with a Hirose DF11-12DP-2DS9(24) connector (male receptacle). (Fig 1) Cable not included. Please request at order entry. Cable connector (female socket) is Hirose DF11-12DS-2C. (Fig 2) Connector specifications: 12 position 2mm pitch dual row (2x6) pin header.

Wire Color	Description
Black	Ground
Red	Power
Blue/White	X-Axis (Dual Output)
Blue	X-Axis
Yellow/Black	Y-Axis (Dual Output)
Yellow	Y-Axis
Green/Black	Z-Axis (Dual Output)
Green	Z-Axis
Orange	Button 1
White	Button Common
Violet	Button 2

* Requires operating voltage $6V \geq 35V$
 ** Requires operating voltage $11V \geq 35V$



Up to IP67 available.







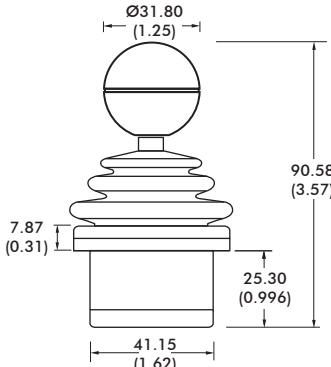
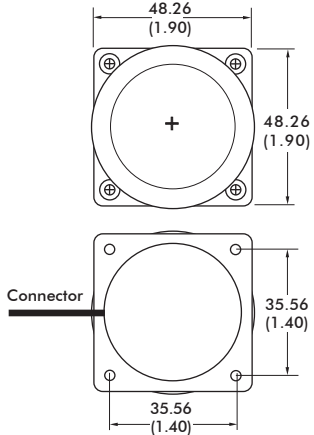

Mounting accessories. Standard hardware includes: gasket, clamping ring, and four #4-40x3/4 Phil Ph MS SS screws.

- Output voltage is ratiometric to supply voltage
- Cable length is 6' from side of joystick to USB connector
- Cable length is 7' from side of joystick to USB connector

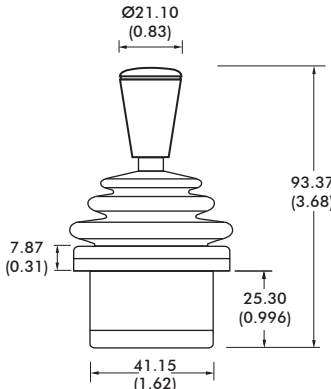
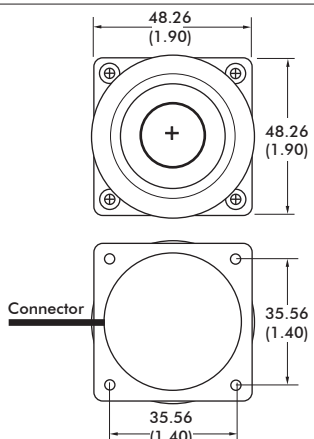

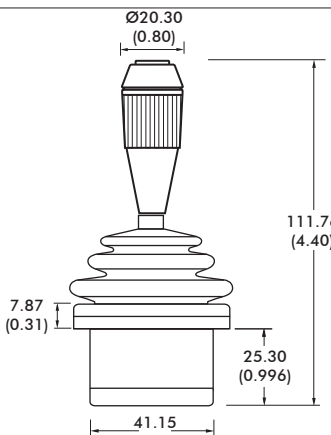
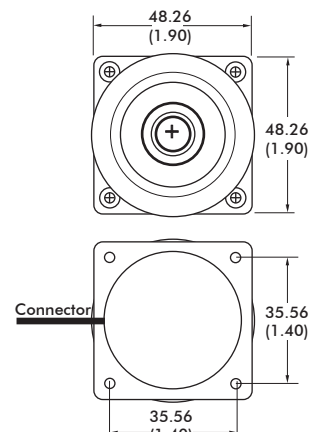
Note: The company reserves the right to change specifications without notice.

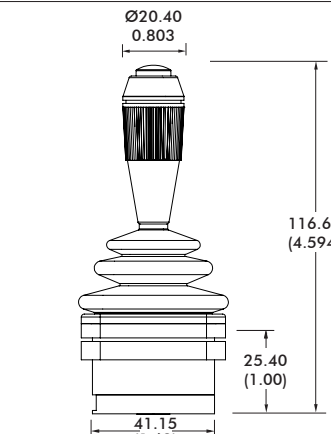
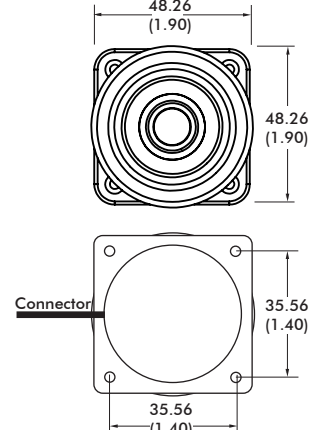
<p style="text-align: center;">10</p> 	 <p> $\varnothing 31.80$ (1.25) 90.58 (3.57) 7.87 (0.31) 25.30 (0.996) 41.15 (1.62) </p>	 <p> 48.26 (1.90) 48.26 (1.90) Connector 35.56 (1.40) 35.56 (1.40) </p>
<p style="text-align: center;">11</p> 	 <p> $\varnothing 21.10$ (0.83) 93.37 (3.68) 7.87 (0.31) 25.30 (0.996) 41.15 (1.62) </p>	 <p> 48.26 (1.90) 48.26 (1.90) Connector 35.56 (1.40) 35.56 (1.40) </p>
<p style="text-align: center;">22</p> 	 <p> $\varnothing 20.30$ (0.80) 111.76 (4.40) 7.87 (0.31) 25.30 (0.996) 41.15 (1.62) </p>	 <p> 48.26 (1.90) 48.26 (1.90) Connector 35.56 (1.40) 35.56 (1.40) </p>
<p style="text-align: center;">27</p> 	 <p> $\varnothing 20.40$ 0.803 116.69 (4.594) 25.40 (1.00) 41.15 (1.62) </p>	 <p> 48.26 (1.90) 48.26 (1.90) Connector 35.56 (1.40) 35.56 (1.40) </p>

HF series

Hall effect joysticks

Overview









Distribución de componentes
eléctricos y electrónicos

Tel.: (+34) 902 450 160

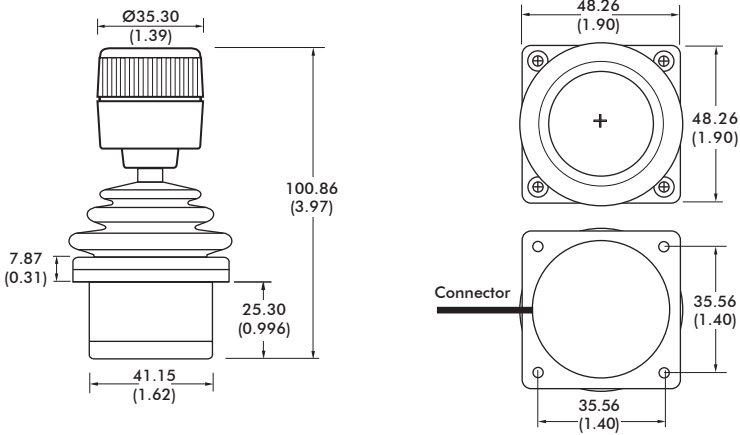
Fax: (+34) 902 433 088

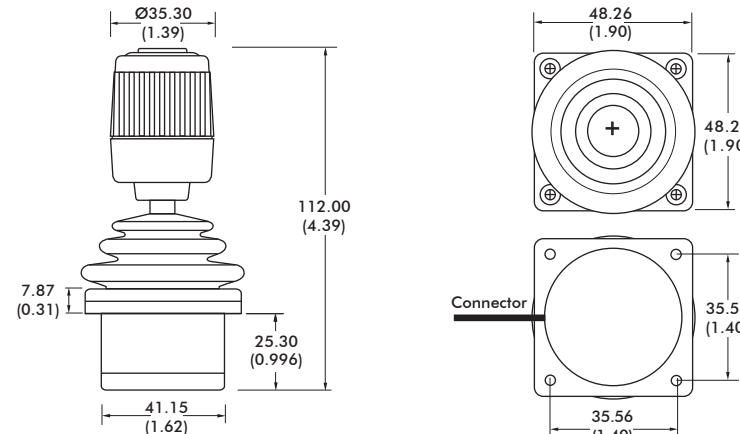
ermec@ermec.com

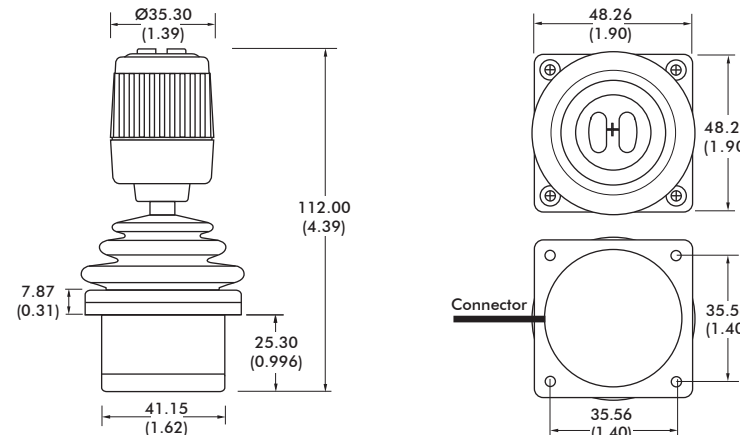
www.ermec.com

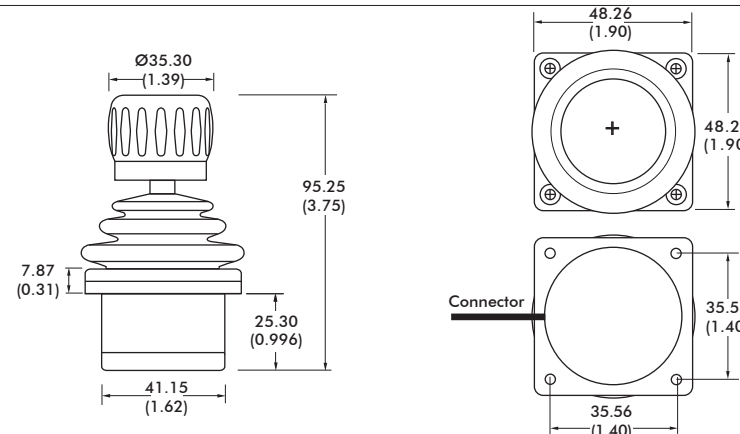
<p style="text-align: center;">33</p> 	
<p style="text-align: center;">44</p> 	
<p style="text-align: center;">45</p> 	
<p style="text-align: center;">46</p> 	

Note: The company reserves the right to change specifications without notice.

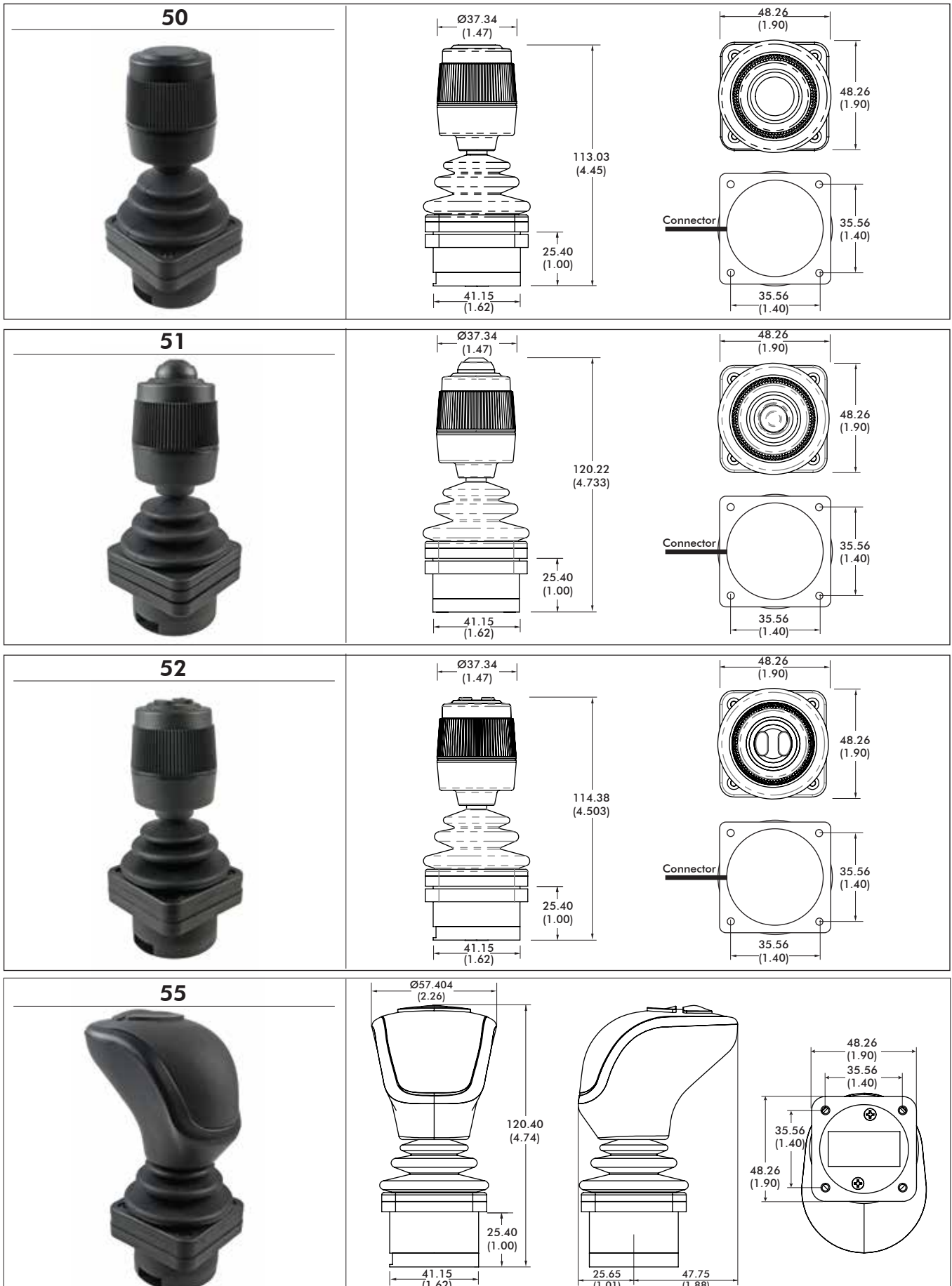

HF series

Hall effect joysticks

Overview



Distribución de componentes eléctricos y electrónicos

Tel.: (+34) 902 450 160

Fax: (+34) 902 433 088

ermec@ermec.com

www.ermec.com

PANEL CUT-OUT DIMENSIONS

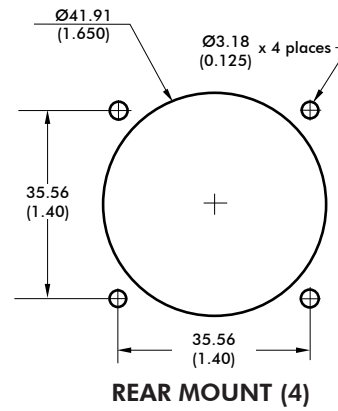
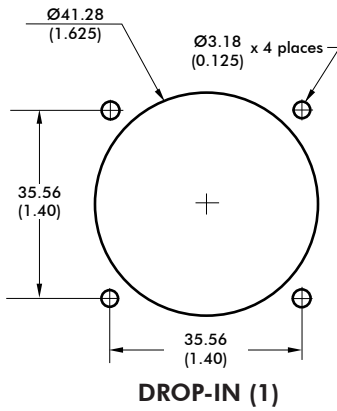

* Not available for Option 11 and 55 Handles

MOUNTING OPTIONS

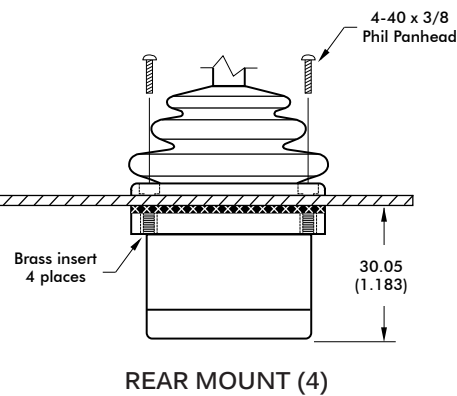
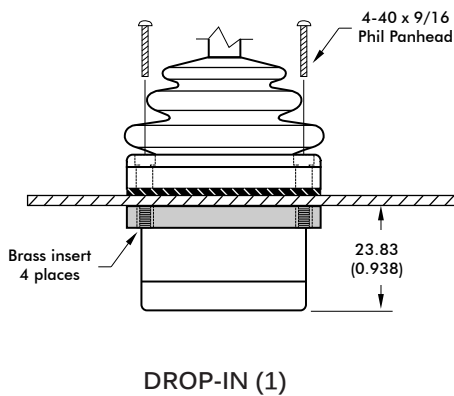

CLAMPING RING

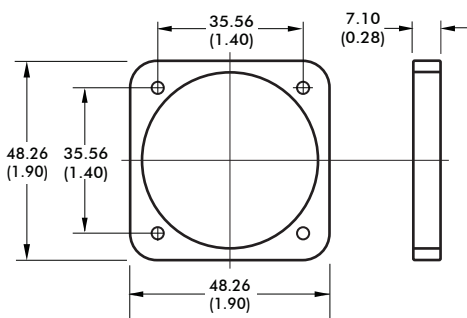

NOTES:

- For DROP-IN mounting, the panel thickness can be 1.17mm to 3.17mm (0.046in to 0.125in).
- For REAR MOUNT the maximum panel thickness is 1.6mm (0.063in).
- A panel thickness of 1/16" (1.6mm/0.063in) was considered for all the below-panel depth values.
- The below-panel depth is extended by 7.11mm (0.28in) with the USB, Cursor Emulation, Voltage Regulator options.

- Panel
- Gasket
- Rear Mount Gasket

NOTES:

1. Dimensions are in mm/(inch).
2. Axis orientation:

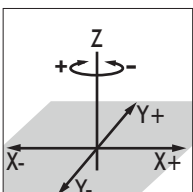

Note: The company reserves the right to change specifications without notice.

HF series

Hall effect joysticks

Overview

VOLTAGE OUTPUT OPTIONS¹

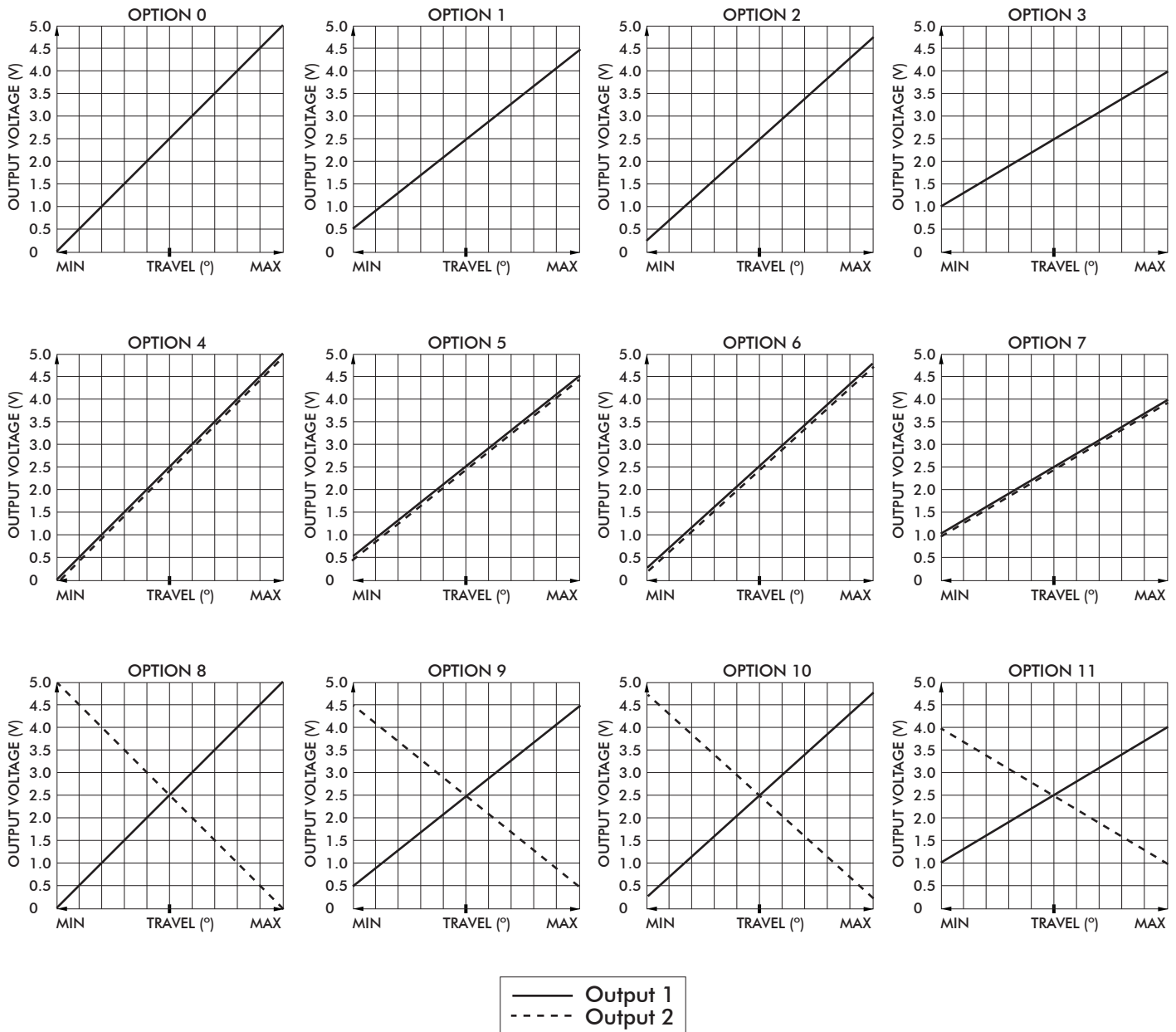

¹ Voltage outputs are ratiometric to supply voltage



Distribución de componentes eléctricos y electrónicos

ERMEC, S.L. BARCELONA
C/ Francesc Teixidó, 22
08918 Badalona
(España)
Tel.: 93.450.16.00

Tel.: (+34) 902 450 160
Fax: (+34) 902 433 088
info@ermec.com
www.ermec.com

ERMEC, S.L. MADRID
c/Puerto Rico, 4
28220 Majadahonda
(España)
Tel.: 91.828.56.51

PORTUGAL
portugal@ermec.com

BILBAO
bilbao@ermec.com

HF series

Hall effect joysticks

Overview



Distribución de componentes
eléctricos y electrónicos

Tel.: (+34) 902 450 160
Fax: (+34) 902 433 088
ermec@ermec.com
www.ermec.com

USB

USB

Featuring USB 2.0 HID compliant interface, APEM's USB joysticks are recognized as standard HID "game controller" devices. Adhering to the HID specification, APEM's USB joysticks are plug-and-play with most versions of Windows. Joystick button and axis assignments are dependent upon the controlled application.

FEATURES

- USB 2.0 HID compliant "game controller" device
- Easy to install and operate
- Functions determined by controlled application
- Standard Male Type A Connector

CURSOR EMULATION

The Cursor Emulation option converts a multi-axis joystick into a mouse, trackball, or cursor control device.

APPLICATIONS

The Cursor Emulation option is ideal for vehicle applications subjected to dirt and high vibration which makes operating a traditional cursor control device difficult. The Cursor Emulation option is widely used in marine and military applications.

FEATURES

- HID compliant "pointing device"
- Plug-and-play with USB option
- Ideal for marine GPS and navigation

TERMINATION OPTIONS

- 0-U USB Male Type A to mini B
Cable length is 6' from side of joystick to USB connector
- 2-U USB Male Type A to vertical cable termination
Cable length is 7' from side of joystick to USB connector

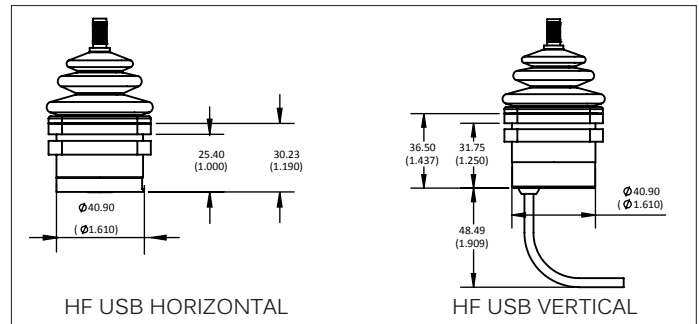

ADDITIONAL OUTPUT OPTIONS

VOLTAGE REGULATOR

The Voltage Regulator option may be used when the operating supply voltage is 11V to 35V..

User Specified Output Voltage:

- 0-5VDC
- ±10VDC

ELECTRICAL SPECIFICATIONS	
• Supply Voltage:	11V to 35V
• Supply Current:	90mA max

WIRING SPECIFICATION	
• Red wire:	Supply (+35V max.)
• Black wire:	Ground
• Blue wire:	X axis output
• Yellow wire:	Y axis output
• Green wire:	Z axis output
• White wire:	Pushbutton common wire
• Orange, violet, grey, brown, pink, bl/wt/y/bk, gn/bk,gy/w wire:	Pushbutton outputs

Note: The company reserves the right to change specifications without notice.

CAN bus

CAN bus ELECTRICAL SPECIFICATIONS

- Operating voltage: 6V to 35V
 - Current consumption: TBD
(typical: 35mA @ 12V, 18mA @ 24V, 15mA @ 30V)
 - Output signal: CAN bus
 - Reverse connection protected: Yes
 - Short-circuit protected against + UB max: Yes
 - Short-circuit protected against GND: Yes
 - CAN: ISO 11898, CAN specification 2.0A/ 2.0B
 - Protocol: CANJ1939, CANJ1939-71, CANopen
 - Baud rate: 125kbit/s, 250kbit/s, 500kbit/s, 1Mbit/s
 - CAN ID: 11/29 bit/s as requested
 - BJM/EJM cycle time: 50ms (standard)/15ms (optional)
 - Terminating resistor: Not included. Available upon request
-
- Operating temperature: -40⁰ to +85⁰C (-40⁰F to 185⁰F)
 - Storage temperature: -40⁰ to +85⁰C (-40⁰F to 185⁰F)
 - Wiring specifications: 22AWG, PTFE, 22" ±.125"
 - Red: Supply power
 - Black: Ground
 - Green: CAN High data
 - White: CAN Low data
 - Blue: Identifier Select LSB
 - Orange: Identifier Select MSB

MOUNTING

Below panel dimensions for CAN bus configurations

